

TWENTY TWENTY FOUR  
MASTER

**Cecil Nurse.**  

---

WORK BETTER.



**Cecil Nurse, is the leading office furniture supplier and manufacturer in Africa. Our diverse portfolio of office furniture systems offers everything you need to create the perfect environment in the modern workplace. We collaborate with you to create innovative and efficiently designed workspace solutions.**

**STOCK** - The products in this catalogue will mostly be in stock meaning products can be quick shipped from our **14 000m<sup>2</sup> distribution centre in Gauteng.**

**INNOVATION** - The Cecil Nurse product development team work with designers, architects, and international partners to create products that are on par with global trends.

**NATIONAL FOOTPRINT** - Our company has a footprint in the main centres in South Africa, Namibia and Botswana, and is geared for exports into the rest of Africa.

**OWN MANUFACTURING** - The Cecil Nurse manufacturing plant is based in Cape Town. The latest CNC software and high-tech machinery are implemented to ensure complete accuracy and quality. The manufacturing plant is **Certified ISO 9001 (Quality Management System).**

**ENVIRONMENT** - The manufacturing plant is **Certified ISO 14001 (Environmental Management System).** At the Cecil Nurse distribution centre in Germiston, all waste is recycled at its recycling plant. Landfill waste is kept to a bare minimum.

**SAFETY** - The particle board used in the manufacturing of our wooden products is manufactured to specification by the local company PG Bison and certified to comply with **E1 Standards** of formaldehyde emission. All our imported task chairs meet international **BIFMA standards and are duly certified.**

**TRANSFORMATION** - Cecil Nurse is totally committed to its role in the transformation of the company and the country, in terms of employment equity, training, learnership and the **B-BBEE** pillars. The company is currently at Level 2.

**BIDVEST** - Cecil Nurse is a wholly owned subsidiary of the **Bidvest Group Ltd.**

**SOCIAL** - Cecil Nurse brings all major international cycling events to SuperSport viewers. This includes **Giro D'Italia, Tour De France** and **La'Vuelta.**

# 06

DESKING



# 152

SEATING



# 208

ACOUSTICS



# 226

RECEPTION



Cecil Nurse a division of Bidvest Office (Pty) Ltd cannot be held liable for any loss or damage suffered by any party as a result of the representations depicted in this catalogue, or the fact that actual sizes may vary in dimension. Cecil Nurse a division of Bidvest Office (Pty) Ltd reserves the right to amend, alter, substitute and/or discontinue any of the products represented in this catalogue. Some items may have been included for display purposes only. Unlawful use of this catalogue will result in copyright infringement. E&OE



# 298

BOARDROOM



# 338

TRAINING



# 366

CANTEEN



# 396

ACCESSORIES

The majority of products depicted in this catalogue have been made exclusively for Cecil Nurse a division of Bidvest Office (Pty) Ltd and Cecil Nurse a division of Bidvest Office (Pty) Ltd claims ownership of all technical specifications, fabrics, components, colours, drawings, layouts, footprints and all matters that relate to the majority of the products depicted in this catalogue. Cecil Nurse a division of Bidvest Office (Pty) Ltd has made every effort to ensure that the representations published in this catalogue are accurate.

Images shown for display purposes only. Actual finishes may vary.





# DESKING



100%  
EXCLUSIVE

**ALLURE**, BIG & BOLD. THIS EXECUTIVE DESK BOASTS A STUNNING TWO-TONE FINISH WITH ALUMINIUM TRIM.

## ALLURE

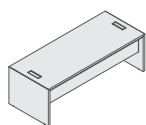

EXECUTIVE DESK  
**ALU2290 + [FINISH]**  
2200 (L) x 900 (W) x 738 (H)

38mm Top & panel legs / 16mm Modesty panel in paired finish / Aluminium trim to front & back edge of desk / Available in CN Exclusive laminates paired with anthracite or black

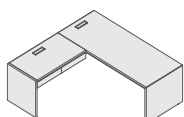

Left hand side shown

EXECUTIVE DESK- INCL. OPEN L-EXTENSION WITH DRAWERS  
**ALU2221 + [L/R] + [FINISH]**  
2200 (L) x 2150 (W) x 738 (H)

38mm Top & panel legs / 16mm Modesty panel in paired finish / Aluminium trim to front & back edge of desk / Open L-extension with aluminium trim to front fitted with 2 x single drawers in paired finish with floating pen & pencil tray / Left or right handed / Available in CN Exclusive laminates paired with anthracite or black

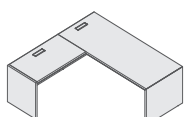

Left hand side shown

EXECUTIVE DESK- INCL. L-EXTENSION  
**ALE2221 + [L/R] + [FINISH]**  
2200 (L) x 2150 (W) x 738 (H)

38mm Top & panel legs / 16mm Modesty panel in paired finish / Aluminium trim to front & back edge of desk / Open L-extension with aluminium trim to front / Left or right handed / Available in CN Exclusive laminates paired with anthracite or black

### LAMINATE FINISHES



ACACIA  
[ACA] / [ACB]



DARK EUCALYPTUS  
[DEA] / [DEB]



NATURAL WALNUT  
[NWA] / [NWB]



TAORMINA ASH  
[TAA] / [TAB]



TRUE OAK  
[TOA] / [TOB]





## **ALLURE STORAGE**

**HINGE DOOR CABINET**  
**ALU820 + [FINISH]**  
1000 (W) x 450 (D) x 1100 (H)

3 x Hinge doors: 2 x square doors in wood grain finish with long door in paired finish / Includes 2 x timber shelves / Black finger grip / Available in CN Exclusive laminates paired with anthracite or black

**MOBILE PEDESTAL**  
**AL705F + [FINISH]**  
533 (W) x 650 (D) x 610 (H)

3 x Standard drawers with hidden pull-out pen & pencil tray / Central locking / Black finger grip handles / Available in CN Exclusive laminates paired with anthracite or black



**DIAMOND**, WITH ITS SPECIAL TRIANGULAR SHAPED LEG PROFILE AND DISCREET AESTHETICS. THIS RANGE WILL HARMONISE BEAUTIFULLY IN ANY MODERN OFFICE LANDSCAPE.

### DIAMOND OPEN LEG STRUCTURES

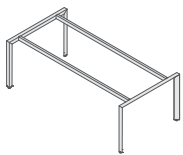

RECTANGULAR DESK LEG STRUCTURE  
**DA2000BLK**  
2000 (L) x 1000 (W) x 722 (H)

Triangular leg profile / Includes 2 x cable outlets for top / Non-handed / Available in black

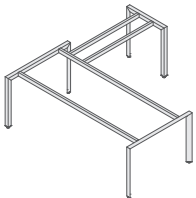

RECTANGULAR DESK LEG STRUCTURE - INCL. L-EXTENSION  
**DA2010BLK**  
2000 (L) x 2000 (W) x 722 (H)

Triangular leg profile / 1000mm L-Extension / Includes 2 x cable outlets for top / Non-handed / Available in black

### DIAMOND LOOP LEG STRUCTURES

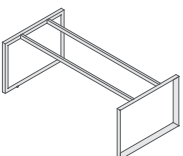

RECTANGULAR DESK LEG STRUCTURE  
**DAL2000BLK**  
2000 (L) x 1000 (W) x 722 (H)

Triangular leg profile / Includes 2 x cable outlets for top / Non-handed / Available in black

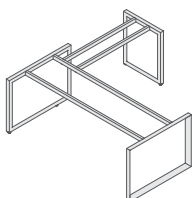

RECTANGULAR DESK LEG STRUCTURE - INCL. L-EXTENSION  
**DAL2010BLK**  
2000 (L) x 2000 (W) x 722 (H)

Triangular leg profile / 1000mm L-Extension / Includes 2 x cable outlets for top / Non-handed / Available in black



## DIAMOND

**DIAMOND TOPS**  
**GTS2010 + [FINISH]** - Managerial worktop  
 2000 (L) x 1000 (W)

**GTS110 + [FINISH]** - Extension top  
 1000 (L) x 600 (W)

16mm Top / Non-handed / Available in CN Exclusive laminates, Anthracite, Stone Grey & White

**NOTE:** Black rectangular access covers included in Diamond leg structure

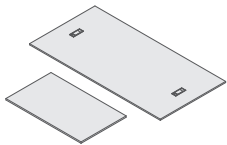

**MODESTY PANEL**  
**GMP1700 + [FINISH]**  
**GMP1700BLK**  
 1700 (L) x 340 (H) x 16mm

Modesty panel includes brackets / Available in CN Exclusive laminates, Anthracite, Black, Stone Grey & White

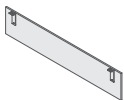

**CABLE TRAY**  
**UBP900BLK**  
 900 (L) x 90 (W) x 90 (H)

**UBP450BLK**  
 450 (L) x 90 (W) x 90 (H)

Available in black

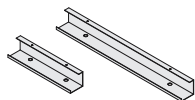

### LAMINATE FINISHES



ACACIA  
[AC]



DARK EUCALYPTUS  
[DE]



NATURAL WALNUT  
[NW]



TAORMINA ASH  
[TA]



TRUE OAK  
[TO]



ANTHRACITE  
[AN]



STONE GREY  
[SG]



WHITE  
[WH]



### **DIAMOND OPEN** LEG STRUCTURE FOR DROPPED STORAGE



**DA2000DBLK**  
2000 (L) x 1000 (W) x 722 (H)

Triangular leg profile / Connects to storage block on dropped extension / Includes 2 x cable outlets for top / Non-handed / Available in black

### **DIAMOND LOOP** LEG STRUCTURE FOR DROPPED STORAGE



**DAL2000DBLK**  
2000 (L) x 1000 (W) x 722 (H)

Triangular leg profile / Connects to storage block on dropped extension / Includes 2 x cable outlets for top / Non-handed / Available in black

### **DIAMOND**

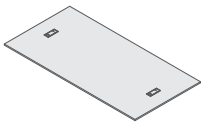

**TOP FOR DROPPED STORAGE**  
**GTSD2010 + [FINISH]**  
2000 (L) x 1000 (W)

16mm Top / Non-handed / Available in CN Exclusive Laminates, Anthracite, Stone Grey & White

**NOTE: Black rectangular access covers included in Diamond leg structure**

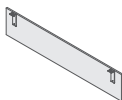

**MODESTY PANEL**  
**GMP1200 + [FINISH]**  
**GMP1200BLK**  
1200 (L) x 340 (H) x 16mm

Modesty panel including brackets / Available in CN Exclusive laminates, Anthracite, Black, Stone Grey & White

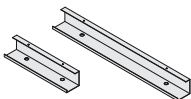

**CABLE TRAY**  
**UBP900BLK**  
900 (L) x 90 (W) x 90 (H)

**UBP450BLK**  
450 (L) x 90 (W) x 90 (H)

Available in black

#### LAMINATE FINISHES



ACACIA  
[AC]



DARK EUCALYPTUS  
[DE]



NATURAL WALNUT  
[NW]



TAORMINA ASH  
[TA]



TRUE OAK  
[TO]



ANTHRACITE  
[AN]



BLACK  
[BLK]



STONE GREY  
[SG]



WHITE  
[WH]



## **DIAMOND STORAGE**

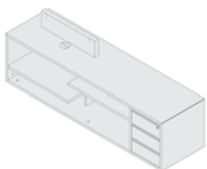

**DROPPED STORAGE EXTENSION - OPEN**  
**DA2055 + [L/R] + [FINISH]**  
 2000 (L) x 550 (W) x 545 (H)

Dropped storage extension including 2 x floating shelves & 3 x drawer pedestal with soft closing drawers / Black finger grip handles / Left or right handed / Available in CN Exclusive Laminates, Anthracite, Black, Stone Grey & White

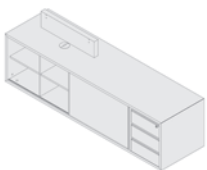

**DROPPED STORAGE EXTENSION - WITH SLIDING DOOR**  
**DAS2055 + [L/R] + [FINISH]**  
 2000 (L) x 550 (W) x 545 (H)

Dropped storage extension with sliding door, fixed pigeon hole compartment & opening with adjustable shelf / 3 x drawer pedestal with soft closing drawers / Black finger grip handles / Left or right handed / Available in CN Exclusive Laminates, Anthracite, Black, Stone Grey & White



**RADIUS**, WITH ITS BEAUTIFUL ROUND TUBE LEG TRANSFORMING THE PRIVATE OFFICE INTO THE CREATIVE OFFICE, WITH ITS SIMPLICITY AND VERSATILITY.



### **RADIUS OPEN** LEG STRUCTURES

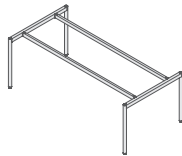

**RECTANGULAR DESK LEG STRUCTURE**  
**RD2000BLK**  
2000 (L) x 1000 (W) x 722 (H)

Round leg profile / Includes 2 x cable outlets for top / Non-handed / Available in black

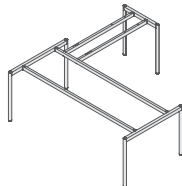

**RECTANGULAR DESK LEG STRUCTURE - INCL. L-EXTENSION**  
**RD2010BLK**  
2000 (L) x 2000 (W) x 722 (H)

Round leg profile / 1000mm L-Extension / Includes 2 x cable outlets for top / Non-handed / Available in black

### **RADIUS**

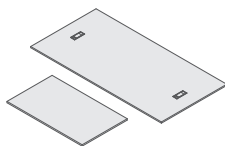

**RADIUS TOPS**  
**GTS2010 + [FINISH]** - Managerial worktop  
2000 (L) x 1000 (W)

**GTS110 + [FINISH]** - Extension top  
1000 (L) x 600 (W)

16mm Top / Non-handed / Available in CN Exclusive laminates, Anthracite, Stone Grey & White

**NOTE: Black rectangular access covers included in Diamond leg structure**

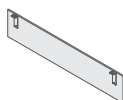

**MODESTY PANEL**  
**GMP1700 + [FINISH]**  
**GMP1700BLK**  
1700 (L) x 340 (H) x 16mm

Modesty panel includes brackets / Available in CN Exclusive laminates, Anthracite, Black, Stone Grey & White

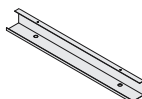

**CABLE TRAY**  
**UBP900BLK**  
900 (L) x 90 (W) x 90 (H)

Available in black



**UBP450BLK**  
450 (L) x 90 (W) x 90 (H)



LAMINATE FINISHES

-  ACACIA [AC]
-  DARK EUCALYPTUS [DE]
-  NATURAL WALNUT [NW]
-  TAORMINA ASH [TA]
-  TRUE OAK [TO]
-  ANTHRACITE [AN]
-  BLACK [BLK]
-  STONE GREY [SC]
-  WHITE [WH]

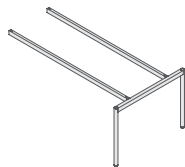

**RADIUS** LEG STRUCTURE FOR DROPPED STORAGE

RECTANGULAR DESK LEG STRUCTURE  
**RD2000DBLK**  
 2000 (L) x 1000 (W) x 722 (H)

Round leg profile / Connects to storage block on dropped extension / Includes 2 x cable outlets for top / Non-handed / Available in black

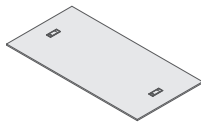

TOP FOR DROPPED STORAGE  
**GTSD2010 + [FINISH]**  
 2000 (L) x 1000 (W)

16mm Top / Non-handed / Available in CN Exclusive Laminates, Anthracite, Stone Grey & White

**NOTE:** Black rectangular access covers included in Diamond leg structure

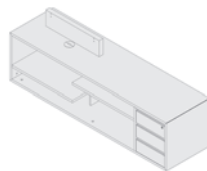

**DIAMOND** STORAGE

DROPPED STORAGE EXTENSION - OPEN  
**DA2055 + [L/R] + [FINISH]**  
 2000 (L) x 550 (W) x 545 (H)

Dropped storage extension including 2 x floating shelves & 3 x drawer pedestal with soft closing drawers / Black finger grip handles / Left or right handed / Available in CN Exclusive Laminates, Anthracite, Black, Stone Grey & White

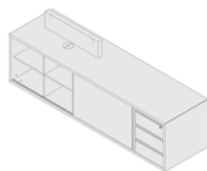

DROPPED STORAGE EXTENSION - WITH SLIDING DOOR  
**DAS2055 + [L/R] + [FINISH]**  
 2000 (L) x 550 (W) x 545 (H)

Dropped storage extension with sliding door, fixed pigeon hole compartment & opening with adjustable shelf / 3 x drawer pedestal with soft closing drawers / Black finger grip handles / Left or right handed / Available in CN Exclusive Laminates, Anthracite, Black, Stone Grey & White

Images shown for display purposes only. Actual finishes may vary.



WOOD IS THE KEY CHARACTERISTIC DESIGN ELEMENT OF **HUNTSMAN WOOD**.

### HUNTSMAN WOOD

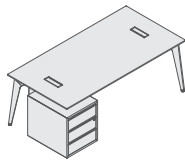

Left hand side shown

EXECUTIVE DESK- INCL. DROPPED PEDESTAL  
**HTM2010 + [L/R] + [BLK]**  
 2000 (W) x 1000 (D) x 737 (H)

12mm Black solid core top with polished edges / Metal understructure in black with solid Oak-stained legs / Modesty panel in Matt black Perspex / Includes dropped 3 x drawer pedestal with soft closing drawers, floating pen & pencil tray in Black laminate / Black finger grip handles / Left or right handed

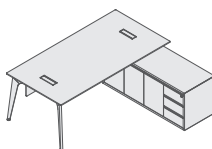

Right hand side shown

EXECUTIVE DESK- INCL. DROPPED L-EXTENSION  
**HTM2018 + [L/R] + [BLK]**  
 2000 (W) x 1800 (W) x 737 (H)

12mm Black solid core top with polished edges / Metal understructure in black with solid Oak-stained legs / Modesty panel in Matt black Perspex / Includes dropped L-extension: 3 x drawer pedestal with soft closing drawers, floating pen & pencil tray, 3 x hinge doors in Black laminate / Black finger grip handles / Left or right handed





## HALLMARK / HUNTSMAN STORAGE

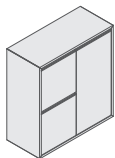

**HINGE DOOR CABINET**  
**HLM820BLK**  
 1000 (W) x 450 (D) x 1100 (H)

3 x Hinge doors / Black finger grip handles / Available in Black laminate

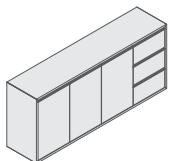

**HINGE DOOR CABINET - WITH DRAWERS**  
**HLM1986DBLK**  
 1964 (W) x 450 (D) x 860 (H)

3 x Hinge doors & 3 standard soft closing drawers / Includes timber shelves / Accommodates lever arch files / Black finger grip handles / Available in Black laminate

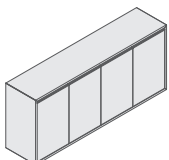

**HINGE DOOR CABINET**  
**HLM1986BLK**  
 1964 (W) x 450 (D) x 860 (H)

4 x Hinge doors / Includes timber shelves / Accommodates lever arch files / Black finger grip handles / Available in Black laminate

Images shown for display purposes only. Actual finishes may vary.



100%  
EXCLUSIVE

**HUNTSMAN STEEL**, A MORE COST EFFECTIVE VERSION OF OUR HUNTSMAN WOOD WITH SHARP TAPERED STEEL LEG AND MATCHING MONOTONE STORAGE.

## HUNTSMAN STEEL

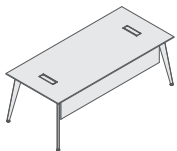

**EXECUTIVE DESK**  
HTMS2090 + [A/B] + [FINISH]  
2000 (W) x 900 (D) x 722 (H)

22mm Supalam top with reverse chamfered edge / Steel frame in Anthracite [A] or Black [B] painted finish / 16mm Modesty panel in Anthracite or Black laminate / Top available in CN Exclusive Supalam finishes, Anthracite & White

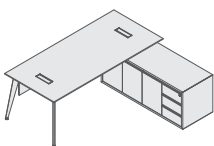

Right hand side shown

**EXECUTIVE DESK - INCL. DROPPED L-EXTENSION**  
HTMS2018 + [A/B] + [L/R] + [FINISH]  
2000 (W) x 1800 (D) x 722 (H)

22mm Supalam top with reverse chamfered edge / Steel frame in Anthracite [A] or Black [B] painted finish / Modesty panel & dropped L-extension: 3 x drawer pedestal with soft closing drawers, floating pen & pencil tray & 3 x hinge doors, in Anthracite or Black laminate to match steel frame / Matching anthracite or black finger grip handles / Left or right handed / Top available in CN Exclusive Supalam finishes, Anthracite & White

### SUPALAM FINISHES



ACACIA  
[AC]



DARK EUCALYPTUS  
[DE]



NATURAL WALNUT  
[NW]



TAORMINA ASH  
[TA]



TRUE OAK  
[TO]



ANTHRACITE  
[AN]



WHITE  
[WH]



## HALLMARK / HUNTSMAN STORAGE



**MOBILE PEDESTAL**  
**HLM705F + [AN/BLK]**  
 400 (W) x 550 (D) x 553 (H)

1 x Floating pen & pencil tray, 3 x standard soft closing drawers / Central locking / Matching anthracite or black finger grip handles / Available in Anthracite & Black laminates

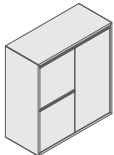

**HINGE DOOR CABINET**  
**HLM820 + [AN/BLK]**  
 1000 (W) x 450 (D) x 1100 (H)

3 x Hinge doors / Matching anthracite or black finger grip handles / Available in Anthracite & Black laminates

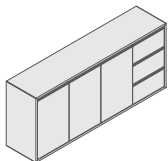

**HINGE DOOR CABINET - WITH DRAWERS**  
**HLM1986D + [AN/BLK]**  
 1964 (W) x 450 (D) x 860 (H)

3 x Hinge doors & 3 x standard soft closing drawers / Includes timber shelves / Accommodates lever arch files / Matching anthracite or black finger grip handles / Available in Anthracite & Black laminates

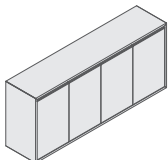

**HINGE DOOR CABINET**  
**HLM1986 + [AN/BLK]**  
 1964 (W) x 450 (D) x 860 (H)

4 x Hinge doors / Includes timber shelves / Accommodates lever arch files / Matching anthracite or black finger grip handles / Available in Anthracite & Black laminates



**HALLMARK**, FEATURES A DISTINCTIVE SOLID TURNED WOODEN LEG, EXPLORING ALL THE POSSIBILITIES OF THE OFFICE TABLE.

### HALLMARK

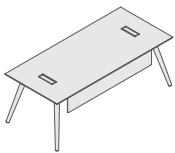

**EXECUTIVE DESK**  
**HLM2090 + [FINISH]**  
 2000 (L) x 900 (D) x 722 (H)

22mm Supalam top with reverse chamfered edge / Metal understructure in anthracite or white with turned solid Oak legs / Modesty panel in Matt Black or Polar White Perspex / Available in Anthracite & White

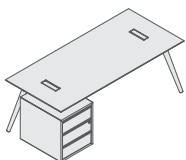

Left hand side shown

**EXECUTIVE DESK - INCL. DROPPED PEDESTAL**  
**HLM2090 + [L/R] + [FINISH]**  
 2000 (W) x 900 (D) x 722 (H)

22mm Supalam top with reverse chamfered edge / Metal understructure in anthracite or white with turned solid Oak leg / Modesty panel in Matt Black or Polar White Perspex / Includes dropped laminate 3 x drawer pedestal with soft closing drawers, floating pen & pencil tray / Matching anthracite or white finger grip handles / Available in Anthracite & White

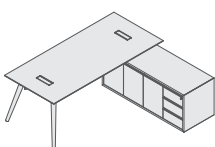

Right hand side shown

**EXECUTIVE DESK - INCL. DROPPED L-EXTENSION**  
**HLM2018 + [L/R] + [FINISH]**  
 2000 (W) x 1800 (D) x 722 (H)

22mm Supalam top with reverse chamfered edge / Metal understructure in anthracite or white with turned solid Oak leg / Modesty panel in Matt Black or Polar White Perspex / Includes dropped laminate L-extension: 3 x drawer pedestal with soft closing drawers, floating pen & pencil tray, 3 x hinge doors / Matching anthracite or white finger grip handles / Available in Anthracite & White laminates



LAMINATE / SUPALAM FINISHES

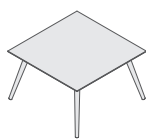

## HALLMARK MEETING

**HLM1212 + [FINISH]**  
1200 (L) x 1200 (W) x 722 (H)

22mm Supalam top with reverse chamfered edge / Metal understructure in anthracite or white with turned solid Oak leg / Available in Anthracite & White





## HALLMARK / HUNTSMAN STORAGE



**MOBILE PEDESTAL**  
**HLM705F + [AN/WH]**  
 400 (W) x 550 (D) x 553 (H)

1 x Floating pen & pencil tray, 3 x standard soft closing drawers / Central locking / Matching anthracite or white finger grip handles / Available in Anthracite & White laminates

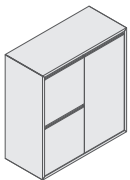

**HINGE DOOR CABINET**  
**HLM820 + [AN/WH]**  
 1000 (W) x 450 (D) x 1100 (H)

3 x Hinge doors / Matching anthracite or white finger grip handles / Available in Anthracite & White laminates

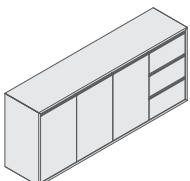

**HINGE DOOR CABINET - WITH DRAWERS**  
**HLM1986D + [AN/WH]**  
 1964 (W) x 450 (D) x 860 (H)

3 x Hinge doors & 3 x standard soft closing drawers / Includes timber shelves / Accommodates lever arch files / Matching anthracite or white finger grip handles / Available in Anthracite & White laminates

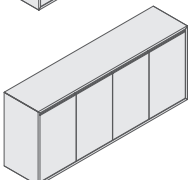

**HINGE DOOR CABINET**  
**HLM1986 + [AN/WH]**  
 1964 (W) x 450 (D) x 860 (H)

4 x Hinge doors / Includes timber shelves / Accommodates lever arch files / Matching anthracite or white finger grip handles / Available in Anthracite & White laminates

### LAMINATE FINISHES





100%  
EXCLUSIVE

**LEO**, STRONGLY CHARACTERISED BY THE SQUARE VOLUME OF ITS LEGS, THE LEO OFFICE DESK HAS CLEAR-CUT LINES FOR A “TIMELESS” FURNISHING CONCEPT, WHICH ADAPTS EASILY TO ALL DESIGN STYLES.

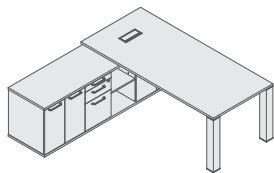

Leo Rectangular Desk with Dropped L-extension

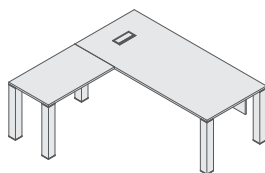

Leo Rectangular Desk with Open L-extension

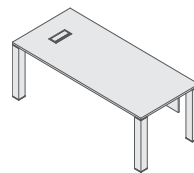

Leo Rectangular Desk

LEG COLOURS

-  ANTHRACITE [AN]
-  BLACK [BLK]
-  SILVER [SI]

LAMINATE FINISHES

-  ACACIA [AC] / [ACA] / [ACB] / [ACW]
-  DARK EUCALYPTUS [DE] / [DEA] / [DEB] / [DEW]
-  NATURAL WALNUT [NW] / [NWA] / [NWB] / [NWW]
-  TRUE OAK [TO] / [TOA] / [TOB] / [TOW]
-  TAORMINA ASH [TA] / [TAA] / [TAB] / [TAW]

LEO BUILD YOUR DESK:

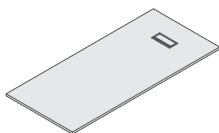

DESK TOP  
LEO2090 + [FINISH]  
2000 (L) x 900 (W) x 25mm

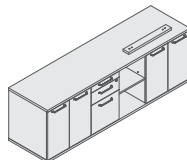

DROPPED L-EXTENSION  
LEO2067 + [FINISH]  
2000 (L) x 600 (W) x 675 (H)

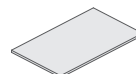

EXTENSION TOP  
LEO110 + [FINISH]  
1000 (L) x 600 (W) x 25mm

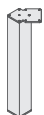

LEO METAL LEG  
LEO700 + [AN/BLK/SI]  
700 (H)

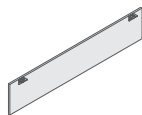

MODESTY PANEL - OPTIONAL  
GMP1700 + [FINISH]  
1700 (L) x 340 (H) x 16mm



CABLE TRAY  
UBP900 + [BLK/SI]  
900 (L) x 90 (W) x 90 (H)

Modesty panel can only be used on open-L and freestanding desks





**LEO FEATURES:**

- **25mm Top:** with metal stiffening bars
- **Leo metal legs:** available in Black, Anthracite & Silver with die-cast aluminium ends
- **L-extension storage:** 1 x pen & pencil drawer, 1 x standard drawer, 1 x deep filer, 4 x hinge doors & 1 x open compartment with shelf
- **Available in:** CN Exclusive laminates or CN Exclusive laminates paired with anthracite, black or white

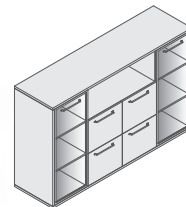

**LEO WALL UNIT**

**LEO2012 + [FINISH]**  
2000 (W) x 450 (D) x 1279 (H)

2 x Frosted glass hinge doors includes timber shelves / 4 x Solid hinge door compartments / Available in CN Exclusive laminates or CN Exclusive laminates paired with anthracite, black or white

Images shown for display purposes only. Actual finishes may vary.



**QUBA** IS PERFECT FOR A MODERN, MINIMALIST WORKING ENVIRONMENT. THE LINEAR, LIGHTWEIGHT METAL LEGS OF THE QUBA RANGE ARE THE KEY ELEMENTS THAT DISTINGUISH THE DESIGN.

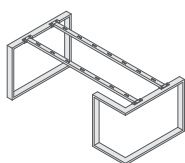

Right hand side shown

### **QUBA**

#### **RECTANGULAR DESK LEG STRUCTURE**

**QB1890 + [L/R] + [BLK]**  
1800 (L) x 900 (W) x 700 (H)

Rectangular leg profile / Includes 1 x 900 (W) Loop leg and 1 x 900 (W) L-leg & beams / Left or right handed / Available in black

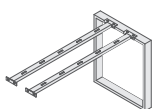

#### **EXTENSION**

**QBE106BLK**  
1000 (L) x 600 (W) x 700 (H)

Rectangular leg profile / Includes 1 x 600 (W) Loop leg & beams / Non-handed / Available in black

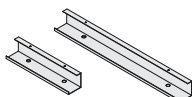

#### **CABLE TRAY**

**UBP900BLK**  
900 (L) x 90 (W) x 90 (H)

**UBP450BLK**  
450 (L) x 90 (W) x 90 (H)

Available in black



LAMINATE FINISHES



ACACIA  
[AC]



DARK EUCALYPTUS  
[DE]



NATURAL WALNUT  
[NW]



TAORMINA ASH  
[TA]



TRUE OAK  
[TO]



ANTHRACITE  
[AN]



STONE GREY  
[SG]



WHITE  
[WH]

**GLOBAL TOPS**

**MANAGERIAL TOP**  
**GTMF1890B + [FINISH]**  
1800 (L) x 900 (W)

25mm Top including 1 x black flip-top cable outlet / Available in CN Exclusive laminates, Anthracite, Stone Grey & White

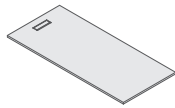

**EXTENSION TOP**  
**GT110 + [FINISH]**  
1000 (L) x 600 (W)

25mm Top / Non-handed / Available in CN Exclusive laminates, Anthracite, Stone Grey & White

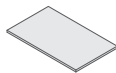

**GLOBAL MODESTY PANEL**  
**GMP1500 + [FINISH]**  
1500 (L) x 340 (H) x 16mm

Modesty panel includes brackets / Available in CN Exclusive laminates, Anthracite, Stone Grey & White

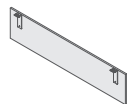

Images shown for display purposes only. Actual finishes may vary.



THE **HUDSON** PERFECTLY REFLECTS LEADERSHIP AND TRUST THROUGH ITS TIMELESS DESIGN AND AESTHETIC ARCHITECTURE.

## HUDSON

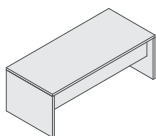

RECTANGULAR DESK  
**HD2090 + [FINISH]**  
 2000 (L) x 900 (W) x 738 (H)

38mm Top & panel legs / Modesty panel in paired finish / Non-handed / Available CN Exclusive laminates paired with anthracite or black

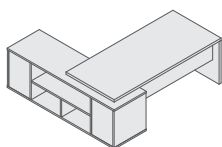

Right hand side shown

RECTANGULAR DESK - INCL. MULTI STORAGE UNIT  
**HD2120 + [L/R] + [FINISH]**  
 2100 (L) x 2000 (W) x 738 (H)

38mm Top & panel leg / Including multi-storage unit fitted with 3 x drawer pedestal / Modesty panel in paired finish / Non-handed / Available CN Exclusive laminates paired with anthracite or black

### LAMINATE FINISHES





## HUDSON STORAGE

**MULTI STORAGE UNIT**  
**HD2060 + [FINISH]**  
 2000 (W) x 600 (D) x 662 (H)

Open unit fitted with fixed shelf to centre / Includes 2 x adjustable shelves / Available in CN  
 Exclusive laminates

### LAMINATE FINISHES



ACACIA  
 [AC]



DARK EUCALYPTUS  
 [DE]



NATURAL WALNUT  
 [NW]



TAORMINA ASH  
 [TA]



TRUE OAK  
 [TO]



DISCREET AESTHETICS MAKES THE **ECOCENTRIC LITE** THE PERFECT CHOICE FOR MANAGERIAL OR CLERICAL WORKSTATIONS.

### ECOCENTRIC LITE

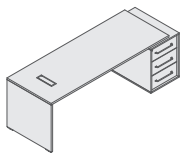

Left hand side shown

DESK - INCL. DROPPED PEDESTAL  
**ECOL2175 + [L/R] + [FINISH]**  
 2175 (L) x 750 (W) x 725 (H)

25mm Top / Includes panel leg, 1 x 3 drawer pedestal & modesty panel / Left or right handed / Drawer fronts & modesty panel in matching wood grain or paired finish / Available in CN Exclusive laminates or CN Exclusive laminates paired with anthracite, black, stone grey or white

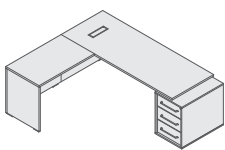

Left hand side shown

DESK - INCL. L-EXTENSION  
**ECOL2117 + [L/R] + [FINISH]**  
 2175 (L) x 1750 (W) x 725 (H)

25mm Top / Includes panel leg, 1 x 3 drawer pedestal & modesty panel / 1000mm Open L-extension / Left or right handed / Drawer fronts & modesty panel in matching wood grain or paired finish / Available in CN Exclusive laminates or CN Exclusive laminates paired with anthracite, black, stone grey or white

#### LAMINATE FINISHES



ACACIA

[AC] / [ACA] / [ACB] / [ACS] / [ACW]



DARK EUCALYPTUS

[DE] / [DEA] / [DEB] / [DEW]



NATURAL WALNUT

[NW] / [NWA] / [NWB] / [NWW]



TAORMINA ASH

[TA] / [TAA] / [TAB] / [TAS] / [TAW]



TRUE OAK

[TO] / [TOA] / [TOB] / [TOW]

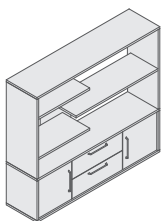

Type A  
Open back

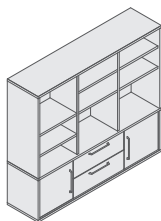

Type B  
Closed back

## ECOCENTRIC STORAGE

### EXECUTIVE WALL UNITS

**ECO1816A + [FINISH]** - Type A: Open back  
**ECO1816B + [FINISH]** - Type B: Closed back  
 1800 (W) x 450 (D) x 1600 (H)

Type A: 2 x wide drawers & 2 x hinge doors / Floating shelves / Wood grain carcass and shelves / Drawer & door fronts, back panel in wood grain or paired finish

Type B: 2 x wide drawers & 2 x hinge doors / Closed shelves / Wood grain carcass, back panel and shelves / Drawer & door fronts in wood grain or paired finish

Type A & B available in a choice of CN Exclusive laminates or CN Exclusive laminates paired with anthracite, black, stone grey or white





DISCREET AESTHETICS MAKES THE **ECOCENTRIC LITE** THE PERFECT CHOICE FOR MANAGERIAL OR CLERICAL WORKSTATIONS.

### ECOCENTRIC STORAGE

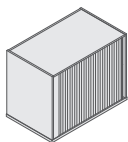

Type B shown

**ROLLER DOOR CREDENZA**  
**GS810 + [A/B] + [B] + [FINISH]** - Black roller door  
**GS810 + [A/B] + [FINISH]** - Silver roller door  
 900 (W) x 550 (D) x 700 (H)

Systemised with optional universal metal storage inners / Excludes extension top / Fits under L-extension / Available in CN Exclusive laminates, Anthracite, Black, Stone Grey or White  
 \*Note: Type A - Roller door opens from left to right (Use with a RHS desk)  
 Type B - Roller door opens from right to left (Use with a LHS desk)

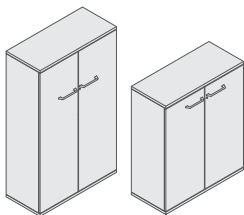

**FILING CABINETS**  
**ECO915 + [FINISH]**  
 900 (W) x 400 (D) x 1500 (H)

**ECO911 + [FINISH]**  
 900 (W) x 400 (D) x 1100 (H)

3-Tier or 4-tier hinge door cabinet options, including timber shelves / Available in CN Exclusive laminates paired with anthracite, black, stone grey or white

#### LAMINATE FINISHES



ACACIA  
 [AC] / [ACA] / [ACB] / [ACS] / [ACW]



DARK EUCALYPTUS  
 [DE] / [DEA] / [DEB] / [DEW]



NATURAL WALNUT  
 [NW] / [NWA] / [NWB] / [NWW]



TAORMINA ASH  
 [TA] / [TAA] / [TAB] / [TAS] / [TAW]



TRUE OAK  
 [TO] / [TOA] / [TOB] / [TOW]



ANTHRACITE  
 [AN]



BLACK  
 [BLK]



STONE GREY  
 [SG]



WHITE  
 [WH]





## **ECOCENTRIC STORAGE**

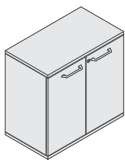

**SINGLE UTILITY UNIT**  
**ECO827 + [FINISH]**  
800 (W) x 450 (D) x 800 (H)

2 x Hinge doors / Includes timber shelves / Available in CN Exclusive laminates paired with anthracite, black, stone grey or white

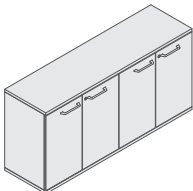

**DOUBLE UTILITY UNIT**  
**ECO828 + [FINISH]**  
1600 (W) x 450 (D) x 800 (H)

4 x Hinge doors / Includes timber shelves / Available in CN Exclusive laminates paired with anthracite, black, stone grey or white

Images shown for display purposes only. Actual finishes may vary.



100%  
EXCLUSIVE

**LEGACY**, A DESK THAT IS CHARACTERISED BY THE STRONG LINES & BRUSHED ALUMINIUM PVC EDGING. THE DROPPED L-EXTENSION WITH DRAWERS MAKES IT THE IDEAL OFFICE DESK FOR MANAGERS WHO NEED TO KEEP DOCUMENTS CLOSE AT HAND.

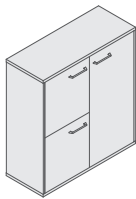

### LEGACY STORAGE

HINGE DOOR CABINET  
LG820 + [FINISH]  
1000 (W) x 450 (D) x 1100 (H)

3 x Hinge doors: 2 x square doors in paired finish with long door in wood grain finish / Includes 2 x timber shelves / Available in CN  
Exclusive laminates paired with anthracite or black





## LEGACY

**DESK**  
**LG2090 + [FINISH]**  
 2000 (L) x 900 (W) x 738 (H)

38mm Top & panel leg with 3D brushed aluminium edging /  
 Modesty panel in paired finish / Non-handed / Available in CN  
 Exclusive laminates paired with anthracite or black

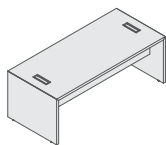

**DESK INCL. EXTENSION**  
**LG1920B + [L/R] + [FINISH]**  
 1900 (L) x 2000 (W) x 738 (H)

38mm Top & panel leg with brushed aluminium PVC edging /  
 Includes open front L-extension: 1 x pen & pencil drawer,  
 3 x standard drawers, 2 x hinge doors & 1 x open compartment with  
 shelf / Modesty panel in paired finish / Left or right handed / Available  
 =in CN Exclusive laminates paired with anthracite or black

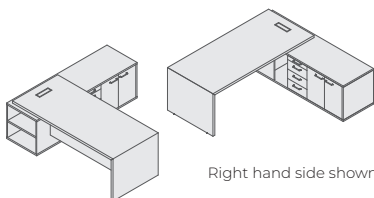

L-extension; carcass in paired finish with door and drawer fronts in wood grain finish

### LAMINATE FINISHES



ACACIA  
 [ACA] / [ACB]



DARK EUCALYPTUS  
 [DEA] / [DEB]



NATURAL WALNUT  
 [NWA] / [NWB]



TAORMINA ASH  
 [TAA] / [TAB]



TRUE OAK  
 [TOA] / [TOB]





# SIT/STAND



100%  
EXCLUSIVE

**EVO DUO**, GIVES THE USERS THE FREEDOM TO CHOOSE BETWEEN SEATED AND STANDING POSTURES, ENHANCING OVERALL WELLBEING OF WORKERS AND ENCOURAGE A MORE HEALTH-CONSCIOUS ENVIRONMENT.

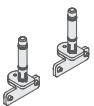

### EVO MUTE DUO SCREEN

EMD1675 + [COLOUR]  
1600 (L) x 750 (H)

24mm Thick / 2 x 9mm 100% Polyester panels with 6mm MDF support panel to middle / Excludes desk mounting brackets / Available in anthracite, black, cloud blue, leaf green, marble, lime, sage green, serenity blue or slate grey

### EVO DUO SCREEN BRACKETS EVB03 + [BLK/WH]

Set of two / Available in Black [BLK] or White [WH]



100% POLYESTER COLOURS



ANTHRACITE  
[AN]



BLACK  
[BLK]



CLOUD BLUE  
[BL]



LEAF GREEN  
[GRN]

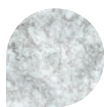

MARBLE  
[MR]



LIME  
[LM]



SAGE GREEN  
[SG]



SERENITY BLUE  
[SBL]



SLATE GREY  
[GR]

100% Polyester is extremely durable and requires little attention to maintain. Light dusting on a regular basis will prevent dust build up. Most marks can be cleaned with a mild detergent solution, followed by rinsing and blotting.

## EVO DUO LEG STRUCTURE

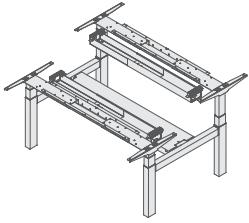

**2-WAY DUAL BENCH**  
**EVD1615 + [BLK/WH]**  
 1575 (L) x 1472 (W) x 650 - 1300 (H)

Motorised 90 x 60 column legs / Includes beams with motor, low and high level cable trays and control system / Excludes control panel\* / Available in Black [BLK] or White [WH]

**NOTE: Control panel must be ordered separately**



**CABLE TRAY CONNECTOR**  
**CTC225 + [BLK/WH]**  
 225 (L) x 200 (W) x 50 (H)

Metal cable tray connector / Available in Black [BLK] or White [WH]  
**Used to connect 2 x End Duo leg structures together**



LEGS & MOTORS ARE  
 MANUFACTURED  
 IN GERMANY

## SIT/STAND CONTROL PANELS:

Control panels available in anthracite / 1 x Control panel required per worktop



HAND CONTROL PANEL  
 UP / DOWN  
 (ILLUMINATES)  
 [CP400BL]



CONTROL PANEL  
 UP / DOWN  
 [CP630AN]



CONTROL PANEL  
 UP / DOWN  
 WITH DISPLAY  
 [CP638AN]



CONTROL PANEL  
 UP / DOWN  
 DISPLAY & MEMORY  
 [CP635AN]

## EVO DUO FEATURES:

- **Adjustment Range:** 650 - 1300mm
- **Noise Level:** <42 dB
- **Adjustment Speed:** 50mm/s
- **Frame Load incl. desk top:** 90kg
- **Telescopic Beam:** 1200 - 1800 mm
- **Power Consumption in standby:** <0,1 W

### ACCESS COVERS



BLACK  
 [CP80BLK]



SILVER  
 [CP80SI]



WHITE  
 [CP80WH]

### LAMINATE FINISHES



ACACIA  
 [AC]



DARK EUCALYPTUS  
 [DE]



NATURAL WALNUT  
 [NW]



TAORMINA ASH  
 [TA]



TRUE OAK  
 [TO]



ANTHRACITE  
 [AN]



STONE GREY  
 [SG]



WHITE  
 [WH]

## EVO WORKTOPS

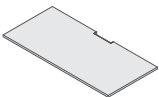

**POWER GAP - SILVER SCALLOP**  
**EVTSC163 + [FINISH]** - 1600 (L) x 750 (W)

**POWER GAP - BLACK SCALLOP**  
**EVTSC163B + [FINISH]** - 1600 (L) x 750 (W)

25mm Rectangular top with power gap in black or silver trim / Non-handed / Available in CN Exclusive laminates, Anthracite, Stone Grey & White

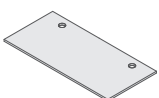

**2 x 80mm Ø CUT-OUTS**  
**EVTI675 + [FINISH]** - 1600 (L) x 750 (W)

25mm Rectangular top with 2 x 80mm Ø cut-outs / Non-handed / Available in CN Exclusive laminates, Anthracite, Stone Grey & White

**NOTE: Access covers must be ordered separately / 80mm Ø cut-out fits DOT Evo power set**



**EVO**, INTEGRATES WELL IN EXISTING ENVIRONMENTS, IT GIVES WORKERS THE FREEDOM TO CHOOSE BETWEEN SEATED AND STANDING POSTURES. BUILT FOR PERFORMANCE AND DURABILITY.





LEGS & MOTORS ARE  
MANUFACTURED  
IN GERMANY



### EVO FEATURES:

- Adjustment Range: 650 - 1300mm
- Noise Level: <42 dB
- Adjustment Speed: 50mm/s
- Frame Load incl. desk top: 90kg
- Telescopic Beam: 1200 - 1800 mm
- Power Consumption in standby: <0,1 W

### SIT/STAND CONTROL PANELS:

Control panels available in anthracite / 1 x Control panel required per worktop

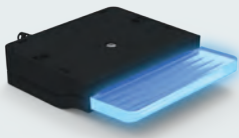

HAND CONTROL PANEL  
UP / DOWN  
(ILLUMINATES)  
[CP400BL]



CONTROL PANEL  
UP / DOWN  
[CP630AN]



CONTROL PANEL  
UP / DOWN  
WITH DISPLAY  
[CP638AN]



CONTROL PANEL  
UP / DOWN  
DISPLAY & MEMORY  
[CP635AN]

### LAMINATE FINISHES



ACACIA  
[AC]



DARK EUCALYPTUS  
[DE]



NATURAL WALNUT  
[NW]



TAORMINA ASH  
[TA]



TRUE OAK  
[TO]



ANTHRACITE  
[AN]



STONE GREY  
[SG]



WHITE  
[WH]

### EVO LEG STRUCTURE

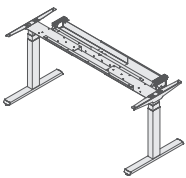

SINGLE DESK  
EVT1218 + [FINISH]  
1200 - 1800 (L) x 680 (W) x 650 - 1300 (H)

Telescopic beam & cable tray allowing for worktops from 1200 - 1800 lengths / Motorised T-legs / Includes beam with motor, cable tray and control system / Excludes control panel\* / Available in Black [BLK] or White [WH]

NOTE: Control panel must be ordered separately

### EVO WORKTOPS

POWER GAP - SILVER SCALLOP  
EVTSC123 + [FINISH] - 1200 (L) x 750 (W)  
EVTSC143 + [FINISH] - 1400 (L) x 750 (W)  
EVTSC163 + [FINISH] - 1600 (L) x 750 (W)  
EVTSC183 + [FINISH] - 1800 (L) x 750 (W)

POWER GAP - BLACK SCALLOP  
EVTSC123B + [FINISH] - 1200 (L) x 750 (W)  
EVTSC143B + [FINISH] - 1400 (L) x 750 (W)  
EVTSC163B + [FINISH] - 1600 (L) x 750 (W)  
EVTSC183B + [FINISH] - 1800 (L) x 750 (W)

25mm Rectangular top with power gap in black or silver trim / Non-handed / Available in CN Exclusive laminates, Anthracite, Stone Grey & White

2 x 80mm Ø CUT-OUTS  
EVTI275 + [FINISH] - 1200 (L) x 750 (W)  
EVTI475 + [FINISH] - 1400 (L) x 750 (W)  
EVTI675 + [FINISH] - 1600 (L) x 750 (W)  
EVTI875 + [FINISH] - 1800 (L) x 750 (W)

25mm Rectangular top with 2 x 80mm Ø cut-outs / Non-handed / Available in CN Exclusive laminates, Anthracite, Stone Grey & White

NOTE: Access covers must be ordered separately / 80mmØ cut-out fits DOT Evo power set

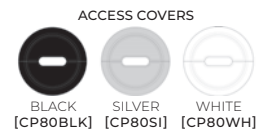



**EVO MUTE SCREENS**, THESE FRAMELESS, PINNABLE SCREENS ARE LIGHT WEIGHT, COLOURFUL AND VERSATILE. THEY FIT ALL OUR SYSTEMS DESKING RANGES. MANUFACTURED FROM 100% POLYESTER, IS EXTREMELY DURABLE AND EASY TO MAINTAIN.

**SCREEN CHARACTERISTICS:**

- Made from 100% polyester
- Sound absorbing
- Water & impact resistant
- Non-toxic, no odour and low VOC emissions
- Fire retardant
- Pinnable surface
- Bacteria and fungi resistant
- Recyclable



**EVO MUTE DESK BASED SCREENS**

- EMSI238 + [COLOUR] - 1200 (L) x 387 (H)
- EMSI438 + [COLOUR] - 1400 (L) x 387 (H)
- EMSI638 + [COLOUR] - 1600 (L) x 387 (H)
- EMSI838 + [COLOUR] - 1800 (L) x 387 (H)

24mm Thick / 2 x 9mm 100% Polyester panels with 6mm MDF support panel to middle / Excludes desk mounting brackets / Available in anthracite, black, cloud blue, leaf green, marble, lime, sage green, serenity blue or slate grey

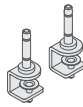

**MIRA DESK SCREEN CLAMPS  
MSB01 + [BLK/WH]**

Set of two / Suitable for 12 - 30mm top / Available in Black [BLK] & White [WH]



**EVO MUTE DROPPED SCREENS**

- EMP1260 + [COLOUR] - 1200 (L) x 600 (H)
- EMP1460 + [COLOUR] - 1400 (L) x 600 (H)
- EMP1660 + [COLOUR] - 1600 (L) x 600 (H)
- EMP1860 + [COLOUR] - 1800 (L) x 600 (H)

24mm Thick / 2 x 9mm 100% Polyester panels with 6mm MDF support panel to middle / Excludes desk mounting brackets / Available in anthracite, black, cloud blue, leaf green, marble, lime, sage green, serenity blue or slate grey

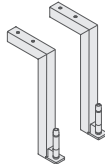

**MIRA DROPPED SCREEN BRACKETS  
MSB02 + [BLK/WH]**

Set of two / Available in Black [BLK] & White [WH]



**EVO MUTE DUO SCREEN**

- EMD1675 + [COLOUR]  
1600 (L) x 750 (H)

24mm Thick / 2 x 9mm 100% Polyester panels with 6mm MDF support panel to middle / Excludes desk mounting brackets / Available in anthracite, black, cloud blue, leaf green, marble, lime, sage green, serenity blue or slate grey

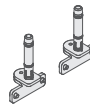

**EVO DUO SCREEN BRACKETS  
EVB03 + [BLK/WH]**

Set of two / Available in Black [BLK] or White [WH]

100% POLYESTER COLOURS



ANTHRACITE [AN]



BLACK [BLK]



CLOUD BLUE [BL]



LEAF GREEN [GRN]

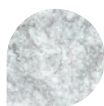

MARBLE [MR]



LIME [LM]



SAGE GREEN [SG]



SERENITY BLUE [SBL]



SLATE GREY [GR]

100% Polyester is extremely durable and requires little attention to maintain. Light dusting on a regular basis will prevent dust build up. Most marks can be cleaned with a mild detergent solution, followed by rinsing and blotting.



**W3 WOBBLE STOOL**, SITTING IN MOVEMENT, THE BASE HAS BEEN SHAPED FROM THERMOPLASTIC SYNTHETIC MATERIALS & IS DIVIDED INTO INDIVIDUAL SEGMENTS. LIKE HIGH-TECH TRAINERS, THE BASE ADJUSTS PERFECTLY TO THE SURFACE & INCLINE, THIS RESULTS IN AN UNIQUE SITTING FEELING.



FABRIC



BLACK [BLK]



GREEN [GRN]



ORANGE [OR]

### W3 WOBBLE STOOL

W306 + [FABRIC]

Fully dynamic black honeycomb supporting base / Aluminium elements in matt black / Black plastic seat upholstered in standard black, green & orange fabric / Dondola 3D-Aktic dynamic seat system / Gas height adjustment (570 - 79mm)

**ZIGGURAT**, OFFERS A DYNAMIC SEAT FOR WORK AND HOSPITALITY THROUGH HEIGHT-ADJUSTMENT AND PIVOTING OR FIXED BASE.



### ZIGGURAT STOOL

ZIGF06BLK - Fixed version  
ZIGO6BLK - Sway version

Dynamic version with domed rubber supporting base / Black disc base / Grip handle activates gas height adjustment / Standard black fabric upholstery



100% EXCLUSIVE

LAMINATE FINISHES



ACACIA [AC]



DARK EUCALYPTUS [DE]



NATURAL WALNUT [NW]



TAORMINA ASH [TA]



TRUE OAK [TO]



ANTHRACITE [AN]



STONE GREY [SG]



WHITE [WH]

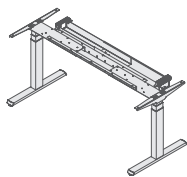
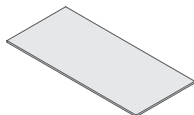

**EVO MEETING TABLE**

**TOP**  
**EVT2210 + [FINISH]**  
 2200 (L) x 1000 (W) x 25mm

25mm Top / Available in CN Exclusive Laminates, Anthracite, Stone Grey & White

**FRAME**  
**EV1218 + [BLK/WH]**  
 1200 - 1800 (L) x 680 (W) x 650 - 1300 (H)

Telescopic beam & cable tray allowing for worktops from 1200 - 1800 lengths / Motorised T-legs / Includes beam with motor, cable tray and control system / Excludes control panel\* / Available in Black [BLK] or White [WH]

**NOTE: Control panel must be ordered separately**



LEGS & MOTORS ARE MANUFACTURED IN GERMANY

**SIT/STAND CONTROL PANELS:**

Control panels available in anthracite / 1 x Control panel required per worktop

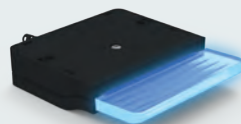

HAND CONTROL PANEL UP / DOWN (ILLUMINATES) [CP400BL]



CONTROL PANEL UP / DOWN [CP630AN]



CONTROL PANEL UP / DOWN WITH DISPLAY [CP638AN]



CONTROL PANEL UP / DOWN DISPLAY & MEMORY [CP635AN]

Images shown for display purposes only. Actual finishes may vary.





# DESK SYSTEMS



THE **DIAMOND** DESK IS NOT JUST A “SIMPLE” BASE, BUT A MEANS THAT BRINGS THE OFFICE TO LIFE AND PROVIDES NECESSARY FLEXIBILITY.

### DIAMOND OPEN LEG STRUCTURES

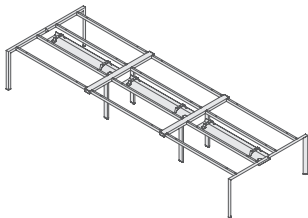

**6-WAY DUAL BENCH - 4800 (L)**  
**DA4816BLK**  
 4800 (L) x 1650 (W) x 722 (H)

**6-WAY DUAL BENCH - 5400 (L)**  
**DA5416BLK**  
 5400 (L) x 1650 (W) x 722 (H)

1600 (L) & 1800 (L) Workspace options / Triangular leg profile / 2 x Recessed intermediate legs / Includes under desk cable management / Available in black

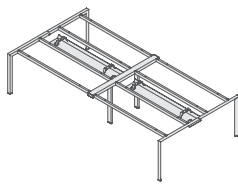

**4-WAY DUAL BENCH - 3200 (L)**  
**DA3216BLK**  
 3200 (L) x 1650 (W) x 722 (H)

**4-WAY DUAL BENCH - 3600 (L)**  
**DA3616BLK**  
 3600 (L) x 1650 (W) x 722 (H)

1600 (L) & 1800 (L) Workspace options / Triangular leg profile / 1 x Recessed intermediate leg / Includes under desk cable management / Available in black

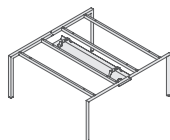

**2-WAY DUAL BENCH - 1600 (L)**  
**DA1616BLK**  
 1600 (L) x 1650 (W) x 722 (H)

**2-WAY DUAL BENCH - 1800 (L)**  
**DA1816BLK**  
 1800 (L) x 1650 (W) x 722 (H)

1600 (L) & 1800 (L) Workspace options / Triangular leg profile / Includes under desk cable management / Available in black

### DIAMOND TOPS

16mm Rectangular top with or without power gap / Non-handed / Available in CN Exclusive laminates, Anthracite, Stone Grey & White

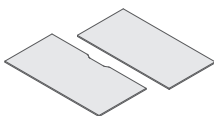

**RECTANGULAR TOP**  
**GTS1680 + [FINISH]** - 1600 (L) x 800 (W)  
**GTS1880 + [FINISH]** - 1800 (L) x 800 (W)

**RECTANGULAR TOP - POWER GAP**  
**GTS168 + [FINISH]** - 1600 (L) x 800 (W)  
**GTS188 + [FINISH]** - 1800 (L) x 800 (W)

#### LAMINATE FINISHES



ACACIA  
[AC]



DARK EUCALYPTUS  
[DE]



NATURAL WALNUT  
[NW]



TAORMINA ASH  
[TA]



TRUE OAK  
[TO]



ANTHRACITE  
[AN]



STONE GREY  
[SG]



WHITE  
[WH]



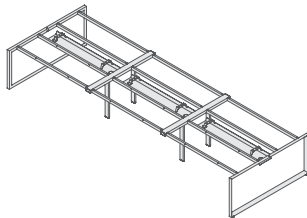

## DIAMOND LOOP LEG STRUCTURES

**6-WAY DUAL BENCH - 4800 (L)**  
**DAL4816BLK**  
 4800 (L) x 1650 (W) x 722 (H)

**6-WAY DUAL BENCH - 5400 (L)**  
**DAL5416BLK**  
 5400 (L) x 1650 (W) x 722 (H)

1600 (L) & 1800 (L) Workspace options / Triangular leg profile / 2 x Recessed intermediate legs / Includes under desk cable management / Available in black

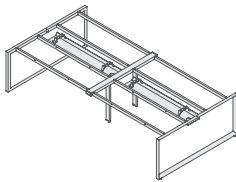

**4-WAY DUAL BENCH - 3200 (L)**  
**DAL3216BLK**  
 3200 (L) x 1650 (W) x 722 (H)

**4-WAY DUAL BENCH - 3600 (L)**  
**DAL3616BLK**  
 3600 (L) x 1650 (W) x 722 (H)

1600 (L) & 1800 (L) Workspace options / Triangular leg profile / 1 x Recessed intermediate leg / Includes under desk cable management / Available in black

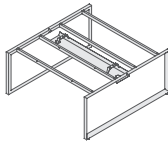

**2-WAY DUAL BENCH - 1600 (L)**  
**DAL1616BLK**  
 1600 (L) x 1650 (W) x 722 (H)

**2-WAY DUAL BENCH - 1800 (L)**  
**DAL1816BLK**  
 1800 (L) x 1650 (W) x 722 (H)

1600 (L) & 1800 (L) Workspace options / Triangular leg profile / Includes under desk cable management / Available in black

## DIAMOND TOPS

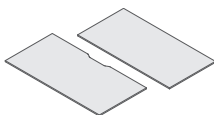

16mm Rectangular top with or without power gap / Non-handed / Available in CN Exclusive laminates, Anthracite, Stone Grey & White

**RECTANGULAR TOP**  
**GTS1680 + [FINISH]** - 1600 (L) x 800 (W)  
**GTS1880 + [FINISH]** - 1800 (L) x 800 (W)

**RECTANGULAR TOP - POWER GAP**  
**GTS168 + [FINISH]** - 1600 (L) x 800 (W)  
**GTS188 + [FINISH]** - 1800 (L) x 800 (W)



100%  
EXCLUSIVE

THE **DIAMOND** LEGS ARE CLEARLY IDENTIFIED BY ITS STANDOUT TRIANGULAR LEG SHAPE. THIS BEAUTIFUL DESK WITH ITS RECTANGULAR SHAPE IS ASTONISHINGLY EYE CATCHING.

### DIAMOND OPEN LEG STRUCTURES

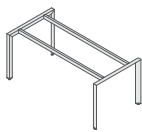

RECTANGULAR DESK LEG STRUCTURE - SINGLE WORKSTATION  
**DA1608BLK** - 1600 (L) x 800 (W) x 722 (H)  
**DA1808BLK** - 1800 (L) x 800 (W) x 722 (H)

1600 (L) & 1800 (L) Workspace options / Includes 2 x cable outlets for top / Non-handed / Triangular leg profile / Available in black

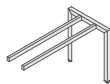

EXTENSION  
**DAE106BLK** - 1000 (L) x 600 (W) x 722 (H)

Non-handed / Triangular leg profile / Available in black

### DIAMOND LOOP LEG STRUCTURES

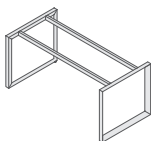

RECTANGULAR DESK LEG STRUCTURE - SINGLE WORKSTATION  
**DAL1608BLK** - 1600 (L) x 800 (W) x 722 (H)  
**DAL1808BLK** - 1800 (L) x 800 (W) x 722 (H)

1600 (L) & 1800 (L) Workspace options / Includes 2 x cable outlets for top / Non-handed / Triangular leg profile / Available in black

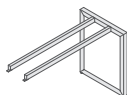

EXTENSION  
**DALE106BLK** - 1000 (L) x 600 (W) x 722 (H)

Non-handed / Triangular leg profile / Available in black



## DIAMOND

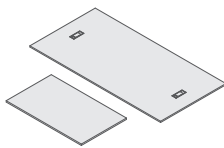

**DIAMOND MANAGERIAL TOPS**  
**GTS1608 + [FINISH]** - 1600 (L) x 800 (W)  
**GTS1808 + [FINISH]** - 1800 (L) x 800 (W)

**DIAMOND EXTENSION TOP**  
**GTS110 + [FINISH]** - 1000 (L) x 600 (W)

16mm Top / Non-handed / Available in CN Exclusive Laminates, Anthracite, Stone Grey & White

**NOTE:** Black rectangular access covers included in Diamond leg structure

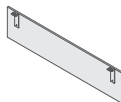

**MODESTY PANELS**  
**GMP1300 + [FINISH]**  
**GMP1300BLK**  
 1300 (L) x 340 (H) x 16mm

**GMP1500 + [FINISH]**  
**GMP1500BLK**  
 1500 (L) x 340 (H) x 16mm

Modesty panel includes brackets / Available in CN Exclusive Laminates, Anthracite, Black, Stone Grey & White

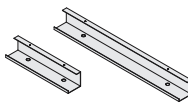

**CABLE TRAY**  
**UBP900BLK**  
 900 (L) x 90 (W) x 90 (H)

**UBP450BLK**  
 450 (L) x 90 (W) x 90 (H)

Available in black

### LAMINATE FINISHES



ACACIA  
[AC]



DARK EUCALYPTUS  
[DE]



NATURAL WALNUT  
[NW]



TAORMINA ASH  
[TA]



TRUE OAK  
[TO]



ANTHRACITE  
[AN]



STONE GREY  
[SG]



WHITE  
[WH]



THE **DIAMOND / RADIUS** PRESPEX SCREENS ARE IDEAL FOR CREATING A DYNAMIC WORKSTATION. SIMPLE BRACKETS SUSPEND THE LIGHTWEIGHT SCREEN BETWEEN THE WORKTOPS, ALLOWING A GAP FOR CABLES.

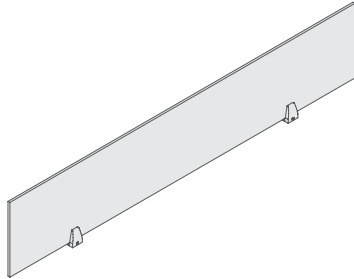

### DIAMOND / RADIUS PERSPEX SCREENS

**DACP1400 + [BLK/WH]** - 1400 (L) x 315 (H)  
**DACP1600 + [BLK/WH]** - 1600 (L) x 315 (H)

5mm Perspex screen available in Matt Black [BLK] or Polar White [WH] / Includes screen brackets in black

\*Height 300 (H) from desk top

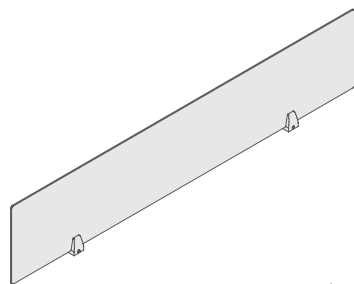

### DIAMOND / RADIUS MUTE DESK BASED SCREEN

**DMD1430 + [COLOUR]** - 1400 (L) x 300 (H)  
**DMD1630 + [COLOUR]** - 1600 (L) x 300 (H)

**DMD1440 + [COLOUR]** - 1400 (L) x 400 (H)  
**DMD1640 + [COLOUR]** - 1600 (L) x 400 (H)

9mm 100% Polyester panels / Excludes screen brackets / Available in anthracite, black, cloud blue, leaf green, marble, lime, sage green, serenity blue or slate grey

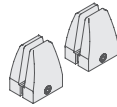

### DIAMOND / RADIUS DUO SCREEN BRACKETS DSB01BLK

Set of two / Fits to cable tray bracket / Available in black

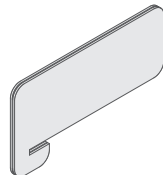

### DIAMOND / RADIUS MUTE COCOON SCREEN

**DCS800 + [COLOUR]**  
 800 (L) x 400 (H)

21mm Thick / 2 x 9mm 100% Polyester panels with 3mm MDF support panel to middle / Easily positioned / No brackets required / Available in anthracite, black, cloud blue, green, marble, lime, sage green or slate grey

\*Fits on 16mm thick worktops only / Height 300 (H) from desktop

#### SCREEN CHARACTERISTICS:

- Made from 100% polyester
- Sound absorbing
- Water & impact resistant
- Non-toxic, no odour and low VOC emissions
- Fire retardant
- Pinnable surface
- Bacteria and fungi resistant
- Recyclable

#### 100% POLYESTER COLOURS



100% Polyester is extremely durable and requires little attention to maintain. Light dusting on a regular basis will prevent dust build up. Most marks can be cleaned with a mild detergent solution, followed by rinsing and blotting.



**RADIUS**, ALLOWS YOU TO CONNECT IN DIFFERENT WAYS FROM DESKING TO SYSTEMS, CREATING AN ENVIRONMENT FOR COLLABORATIVE TEAMWORK.

### RADIUS LEG STRUCTURES

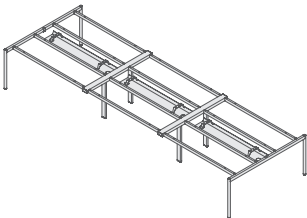

**6-WAY DUAL BENCH - 4800 (L)**  
**RD4816BLK**  
 4800 (L) x 1650 (W) x 722 (H)

1600 (L) & 1800 (L) Workspace options / Round leg profile / 2 x Recessed intermediate legs / Includes under desk cable management / Available in black

**6-WAY DUAL BENCH - 5400 (L)**  
**RD5416BLK**  
 5400 (L) x 1650 (W) x 722 (H)

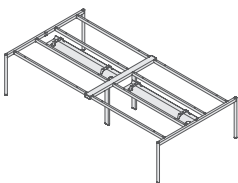

**4-WAY DUAL BENCH - 3200 (L)**  
**RD3216BLK**  
 3200 (L) x 1650 (W) x 722 (H)

1600 (L) & 1800 (L) Workspace options / Round leg profile / 1 x Recessed intermediate leg / Includes under desk cable management / Available in black

**4-WAY DUAL BENCH - 3600 (L)**  
**RD3616BLK**  
 3600 (L) x 1650 (W) x 722 (H)

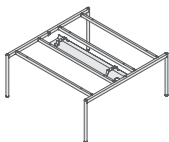

**2-WAY DUAL BENCH - 1600 (L)**  
**RD1616BLK**  
 1600 (L) x 1650 (W) x 722 (H)

1600 (L) & 1800 (L) Workspace options / Round leg profile / Includes under desk cable management / Available in black

**2-WAY DUAL BENCH - 1800 (L)**  
**RD1816BLK**  
 1800 (L) x 1650 (W) x 722 (H)

### RADIUS TOPS

16mm Rectangular top with or without power gap / Non-handed / Available in CN Exclusive laminates, Anthracite, Stone Grey & White

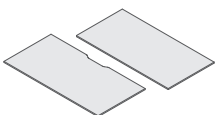

**RECTANGULAR TOPS**  
**GTS1680 + [FINISH]** - 1600 (L) x 800 (W)  
**GTS1880 + [FINISH]** - 1800 (L) x 800 (W)

**RECTANGULAR TOPS - POWER GAP**  
**GTS168 + [FINISH]** - 1600 (L) x 800 (W)  
**GTS188 + [FINISH]** - 1800 (L) x 800 (W)

#### LAMINATE FINISHES



ACACIA  
[AC]



DARK EUCALYPTUS  
[DE]



NATURAL WALNUT  
[NW]



TAORMINA ASH  
[TA]



TRUE OAK  
[TO]



ANTHRACITE  
[AN]



STONE GREY  
[SG]



WHITE  
[WH]



## RADIUS LEG STRUCTURES

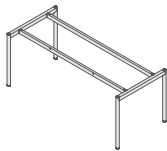

### RECTANGULAR DESK LEG STRUCTURE - SINGLE WORKSTATION

**RD1608BLK** - 1600 (L) x 800 (W) x 722 (H)

**RD1808BLK** - 1800 (L) x 800 (W) x 722 (H)

1600 (L) & 1800 (L) Workspace options / Includes 2 x cable outlets for top / Non-handed / Round leg profile / Available in black

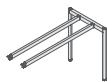

### EXTENSION

**RDE106BLK** - 1000 (L) x 600 (W) x 722 (H)

Non-handed / Round leg profile / Available in black

## RADIUS

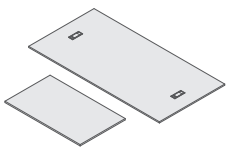

### RADIUS MANAGERIAL TOPS

**GTS1608 + [FINISH]** - 1600 (L) x 800 (W)

**GTS1808 + [FINISH]** - 1800 (L) x 800 (W)

### RADIUS EXTENSION TOP

**GTS110 + [FINISH]** - 1000 (L) x 600 (W)

16mm Top / Non-handed / Available in CN Exclusive Laminates, Anthracite, Stone Grey & White

**NOTE: Black rectangular access covers included in Radius leg structure**

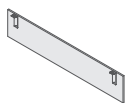

### MODESTY PANELS

**GMP1500 + [FINISH]**

1500 (L) x 340 (H) x 16mm

Modesty panel includes brackets / Available in CN Exclusive Laminates, Anthracite, Stone Grey & White

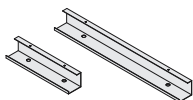

### CABLE TRAY

**UBP900BLK**  
900 (L) x 90 (W) x 90 (H)

**UBP450BLK**  
450 (L) x 90 (W) x 90 (H)

Available in black



**DIAGONAL STREET** STRIKES THE PERFECT BALANCE BETWEEN SOPHISTICATION AND SIMPLICITY. BOASTING A MODERN YET CLASSIC DESIGN WITH ITS RICH SOLID WOODEN LEG.

### DIAGONAL STREET

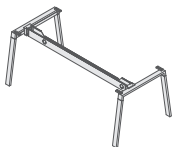

MANAGERIAL DESK  
**DS1890WD** - White understructure  
**DS1890SWD** - Anthracite understructure  
 1800 (L) x 900 (W) x 700 (H)

60 x 40mm Solid Oak legs with metal understructure in anthracite or white / Intergrated cable tray

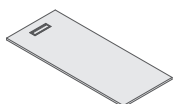

MANAGERIAL WORKTOP  
**GTMF1890 + [FINISH]** - Silver flip-top cable outlet  
**GTMF1890B + [FINISH]** - Black flip-top cable outlet  
 1800 (L) x 900 (W) x 25mm

25mm Rectangular top with 1 x flip-top cable outlet / Available in Anthracite, Natural Walnut & White laminates

#### LAMINATE FINISHES



ANTHRACITE  
[AN]



NATURAL WALNUT  
[NW]



WHITE  
[WH]





## DIAGONAL STREET

### SINGLE DESK

WHITE UNDERSTRUCTURE

**DS1475WD** - 1400 (L) x 750 (W) x 700 (H)

**DS1675WD** - 1600 (L) x 750 (W) x 700 (H)

ANTHRACITE UNDERSTRUCTURE

**DS1475SWD** - 1400 (L) x 750 (W) x 700 (H)

**DS1675SWD** - 1600 (L) x 750 (W) x 700 (H)

1400 (L) & 1600 (L) Workspace options / 60 x 40mm Solid Oak legs with metal understructure in anthracite or white / Intergrated cable tray

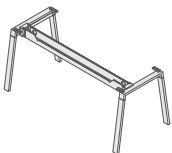

### 2-WAY DUAL BENCH

WHITE UNDERSTRUCTURE

**DS1415WD** - 1400 (L) x 1514 (W) x 700 (H)

**DS1615WD** - 1600 (L) x 1514 (W) x 700 (H)

ANTHRACITE UNDERSTRUCTURE

**DS1415SWD** - 1400 (L) x 1514 (W) x 700 (H)

**DS1615SWD** - 1600 (L) x 1514 (W) x 700 (H)

1400 (L) & 1600 (L) Workspace options / 60 x 40mm Solid Oak legs with metal understructure in anthracite or white / Intergrated cable trays

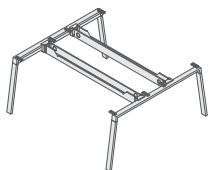



**DIAGONAL STREET** DELIVERS AN ARCHITECTURAL DESIGN SOLUTION FOR PRIVATE AND OPEN PLAN OFFICES.

### DIAGONAL STREET

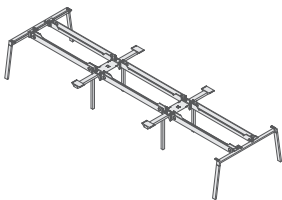

**6-WAY DUAL BENCH**  
 WHITE UNDERSTRUCTURE  
**DS4215WD** - 4200 (L) x 1514 (W) x 700 (H)  
**DS4815WD** - 4800 (L) x 1514 (W) x 700 (H)

ANTHRACITE UNDERSTRUCTURE  
**DS4215SWD** - 4200 (L) x 1514 (W) x 700 (H)  
**DS4815SWD** - 4800 (L) x 1514 (W) x 700 (H)

1400 (L) & 1600 (L) Workspace options / 60 x 40mm Solid Oak legs with metal understructure in anthracite or white painted finish / 2 x Recessed intermediate legs / Intergrated cable trays

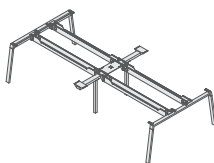

**4-WAY DUAL BENCH**  
 WHITE UNDERSTRUCTURE  
**DS2815WD** - 2800 (L) x 1514 (W) x 700 (H)  
**DS3215WD** - 3200 (L) x 1514 (W) x 700 (H)

ANTHRACITE UNDERSTRUCTURE  
**DS2815SWD** - 2800 (L) x 1514 (W) x 700 (H)  
**DS3215SWD** - 3200 (L) x 1514 (W) x 700 (H)

1400 (L) & 1600 (L) Workspace options / 60 x 40mm Solid Oak legs with metal understructure in anthracite or white painted finish / 1 x Recessed intermediate leg / Intergrated cable trays



## GLOBAL WORKTOPS

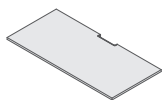

**POWER GAP - SILVER SCALLOP**  
**GTSC143 + [FINISH]** - 1400 (L) x 750 (W)  
**GTSC163 + [FINISH]** - 1600 (L) x 750 (W)

25mm Rectangular top with power gap in black or silver trim / Non-handed / Available in Anthracite, Natural Walnut & White laminates

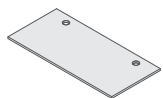

**2 x 80mm Ø CUT-OUTS**  
**GT1475 + [FINISH]** - 1400 (L) x 750 (W)  
**GT1675 + [FINISH]** - 1600 (L) x 750 (W)

25mm Rectangular top with 2 x 80mm Ø cut-outs / Non-handed / Available in Anthracite, Natural Walnut & White laminates

**NOTE:** Access covers must be ordered separately / 80mm Ø cut-out fits DOT Evo power set

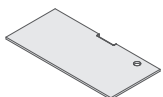

Right hand side shown

**80 Ø CUT-OUT FOR DOT EVO\* - Silver Scallop**  
**GTDSC143 + [L/R] + [FINISH]** - 1400 (L) x 750 (W)  
**GTDSC163 + [L/R] + [FINISH]** - 1600 (L) x 750 (W)

25mm Rectangular top with 1 x 80mm Ø cut-out / Handed / Available in Anthracite, Natural Walnut & White laminates

\*Fits DOT Evo power set  
**DE11N + [BLK/WH]**  
 (Must be ordered separately)

**POWER GAP - BLACK SCALLOP**  
**GTSC143B + [FINISH]** - 1400 (L) x 750 (W)  
**GTSC163B + [FINISH]** - 1600 (L) x 750 (W)

**80 Ø CUT-OUT FOR DOT EVO\* - Black Scallop**  
**GTDSC143B + [L/R] + [FINISH]** - 1400 (L) x 750 (W)  
**GTDSC163B + [L/R] + [FINISH]** - 1600 (L) x 750 (W)

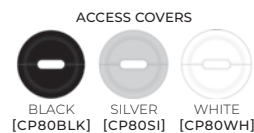

### LAMINATE FINISHES

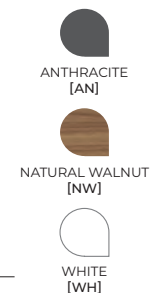



100%  
EXCLUSIVE

**KEYWORK** ALLOWS FOR STREAMLINED YET ROBUST, FLEXIBLE SOLUTIONS, HANDLING CABLE MANAGEMENT & POWER RETICULATION WITHIN THE ADJUSTABLE BEAMS.

### KEYWORK LEG STRUCTURES

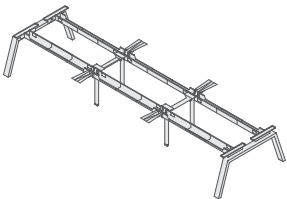

**6-WAY DUAL BENCH**  
**KW4815 + [BLK/WH]** - 4800 (L) x 1500 (W) x 700 (H)  
**KW5415 + [BLK/WH]** - 5400 (L) x 1500 (W) x 700 (H)

Numerous workspace options / Recessed intermediate legs / Intergrated cable trays / Available in Black [BLK] or White [WH]

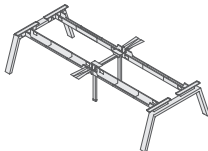

**4-WAY DUAL BENCH**  
**KW3215 + [BLK/WH]** - 3200 (L) x 1500 (W) x 700 (H)  
**KW3615 + [BLK/WH]** - 3600 (L) x 1500 (W) x 700 (H)

Numerous workspace options / Recessed intermediate leg / Intergrated cable trays / Available in Black [BLK] or White [WH]

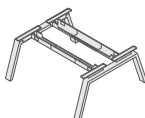

**2-WAY DUAL BENCH**  
**KW1615 + [BLK/WH]** - 1600 (L) x 1500 (W) x 700 (H)  
**KW1815 + [BLK/WH]** - 1800 (L) x 1500 (W) x 700 (H)

Numerous workspace options / Intergrated cable trays / Available in Black [BLK] or White [WH]

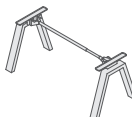

**SINGLE DESK**  
**KWA1807 + [BLK/WH]** - 1200 - 1800 (L) x 700 (W) x 700 (H)  
**KWA2407 + [BLK/WH]** - 1800 - 2400 (L) x 700 (W) x 700 (H)

Numerous workspace options / Available in Black [BLK] or White [WH]

### LAMINATE FINISHES





## KEYWORK WORKTOPS

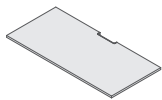

**POWER GAP - SILVER SCALLOP**  
**KWSC123 + [FINISH]** - 1200 (L) x 750 (W)  
**KWSC143 + [FINISH]** - 1400 (L) x 750 (W)  
**KWSC163 + [FINISH]** - 1600 (L) x 750 (W)  
**KWSC183 + [FINISH]** - 1800 (L) x 750 (W)

**POWER GAP - BLACK SCALLOP**  
**KWSC123B + [FINISH]** - 1200 (L) x 750 (W)  
**KWSC143B + [FINISH]** - 1400 (L) x 750 (W)  
**KWSC163B + [FINISH]** - 1600 (L) x 750 (W)  
**KWSC183B + [FINISH]** - 1800 (L) x 750 (W)

25mm Rectangular top with power gap in black or silver trim / Non-handed / Available in CN Exclusive laminates, Anthracite, Stone Grey & White

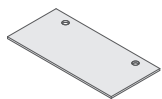

**2 x 80mm Ø CUT-OUTS**  
**KWT1275 + [FINISH]** - 1200 (L) x 750 (W)  
**KWT1475 + [FINISH]** - 1400 (L) x 750 (W)  
**KWT1675 + [FINISH]** - 1600 (L) x 750 (W)  
**KWT1875 + [FINISH]** - 1800 (L) x 750 (W)

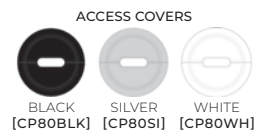

25mm Rectangular top with 2 x 80mm Ø cut-outs / Non-handed / Available in CN Exclusive laminates, Anthracite, Stone Grey & White

**NOTE: Access covers must be ordered separately / 80mmØ cut-out fits DOT Evo power set**

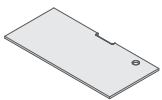

Right hand side shown

**80 Ø CUT-OUT FOR DOT EVO\* - Silver Scallop**  
**KWDSC123 + [L/R] + [FINISH]** - 1200 (L) x 750 (W)  
**KWDSC143 + [L/R] + [FINISH]** - 1400 (L) x 750 (W)  
**KWDSC163 + [L/R] + [FINISH]** - 1600 (L) x 750 (W)  
**KWDSC183 + [L/R] + [FINISH]** - 1800 (L) x 750 (W)

**80 Ø CUT-OUT FOR DOT EVO\* - Black Scallop**  
**KWDSC123B + [L/R] + [FINISH]** - 1200 (L) x 750 (W)  
**KWDSC143B + [L/R] + [FINISH]** - 1400 (L) x 750 (W)  
**KWDSC163B + [L/R] + [FINISH]** - 1600 (L) x 750 (W)  
**KWDSC183B + [L/R] + [FINISH]** - 1800 (L) x 750 (W)

25mm Rectangular top with 1 x 80mm Ø cut-out / Handed / Available in CN Exclusive laminates, Anthracite, Stone Grey & White

\*Fits DOT Evo power set  
**DE11N + [BLK/WH]**  
 (Must be ordered separately)

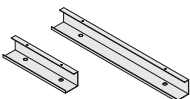

**CABLE TRAY**  
**UBP900 + [BLK/WH]**  
 900 (L) x 90 (W) x 90 (H)

**UBP450 + [BLK/WH]**  
 450 (L) x 90 (W) x 90 (H)

Available in Black [BLK] or White [WH]



KEYWORK COMPONENTS:

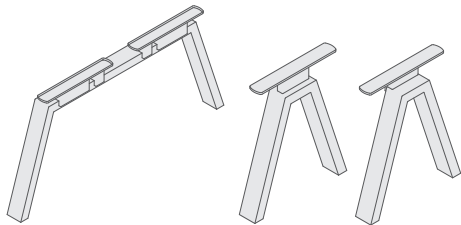

LEG COMPONENTS  
**KW1500 + [BLK/WH]** - 1500 (W) End leg incl. 2 x connectors  
**KWM750 + [BLK/WH]** - 580 (W) Intermediate leg incl. 1 x connector  
**KW750 + [BLK/WH]** - 730 (W) End leg incl. 1 x connector

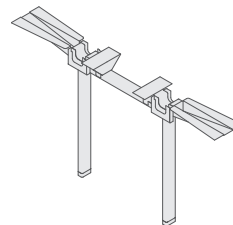

SUPPORT LEG  
**BKWR600 + [BLK/WH]** - Recessed intermediate leg

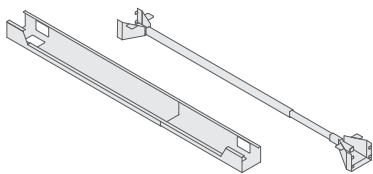

DUAL BENCH SUPPORT BEAMS

**BFW1800 + [BLK/WH]** - 1200 - 1800mm Adjustable beam  
**BFW2400 + [BLK/WH]** - 1800 - 2400mm Adjustable beam

SINGLE DESK SUPPORT BEAMS

**KWB1800 + [BLK/WH]** - 1200 - 1800mm Adjustable beam  
**KWB2400 + [BLK/WH]** - 1800 - 2400mm Adjustable beam

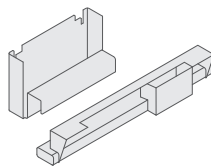

BRACKETS

**BFWBB90 + [BLK/WH]** - Extension beam bracket  
**BWSB800 + [BLK/WH]** - Storage block  
 (Used in conjunction with Global Managerial Dropped Storage)



**BENCHWORK** COMBINES STYLE, AESTHETICS, PRACTICALTY & FLEXIBILITY INTO ONE. A TIMELESS DESIGN WITH GEOMETRIC LINES ENHANCED WITH AN ATTRACTIVE FLOATING TOP.



**BENCHWORK FEATURES:**

- 60 x 30mm Leg profile
- Integrated cable management
- Telescopic central beam for adjustable widths
- Single tool fittings, makes for easy installation
- Frame carries a 10 year guarantee





## BENCHWORK LEG STRUCTURES

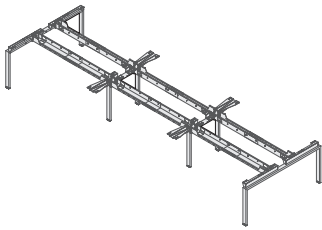

**6-WAY DUAL BENCH**  
**BW4815 + [BLK/SI/WH]**  
 4800 (L) x 1500 (W) x 695 (H)

**BW5415 + [BLK/SI/WH]**  
 5400 (L) x 1500 (W) x 695 (H)

Numerous workspace options / Rectangular leg profile / 2 x Recessed intermediate legs / Integrated cable trays / Available in Black [BLK], Silver [SI] or White [WH]

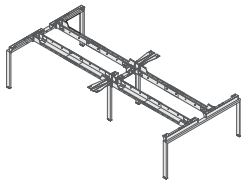

**4-WAY DUAL BENCH**  
**BW3215 + [BLK/SI/WH]**  
 3200 (L) x 1500 (W) x 695 (H)

**BW3615 + [BLK/SI/WH]**  
 3600 (L) x 1500 (W) x 695 (H)

Numerous workspace options / Rectangular leg profile / 1 x Recessed intermediate leg / Integrated cable trays / Available in Black [BLK], Silver [SI] or White [WH]

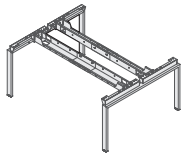

**2-WAY DUAL BENCH**  
**BW1615 + [BLK/SI/WH]**  
 1600 (L) x 1500 (W) x 695 (H)

**BW1815 + [BLK/SI/WH]**  
 1800 (L) x 1500 (W) x 695 (H)

Numerous workspace options / Rectangular leg profile / Integrated cable trays / Available in Black [BLK], Silver [SI] or White [WH]

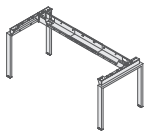

**SINGLE DESK**  
**BWA1807 + [BLK/SI/WH]**  
 1200 - 1800 (L) x 700 (W) x 695 (H)

**BWA2407 + [BLK/SI/WH]**  
 1800 - 2400 (L) x 700 (W) x 695 (H)

Numerous workspace options / Rectangular leg profile / Integrated cable tray / Available in Black [BLK], Silver [SI] or White [WH]



**EXTENSION MODULE**  
**BWE1800 + [BLK/SI/WH]**  
 1200 - 1800 (L) x 600 (W) x 695 (H)

Rectangular leg profile / Includes 1 x leg with adjustable beam & extension bracket / Integrated cable tray / Available in Black [BLK], Silver [SI] or White [WH]



**BENCHWORK** OFFERS EFFORTLESS SETUP AND QUICK RECONFIGURATION, MAKING IT THE PERFECT SYSTEM FOR FLEXIBILITY AND MODERN DESIGN IN THE OFFICE.

### GLOBAL WORKTOPS

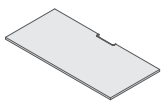

**POWER GAP - SILVER SCALLOP**  
**GTSC123 + [FINISH]** - 1200 (L) x 750 (W)  
**GTSC143 + [FINISH]** - 1400 (L) x 750 (W)  
**GTSC163 + [FINISH]** - 1600 (L) x 750 (W)  
**GTSC183 + [FINISH]** - 1800 (L) x 750 (W)

**POWER GAP - BLACK SCALLOP**  
**GTSC123B + [FINISH]** - 1200 (L) x 750 (W)  
**GTSC143B + [FINISH]** - 1400 (L) x 750 (W)  
**GTSC163B + [FINISH]** - 1600 (L) x 750 (W)  
**GTSC183B + [FINISH]** - 1800 (L) x 750 (W)

25mm Rectangular top with power gap in black or silver trim / Non-handed / Available in CN Exclusive laminates, Anthracite, Stone Grey & White

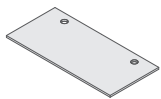

**2 x 80mm Ø CUT-OUTS**  
**GT1275 + [FINISH]** - 1200 (L) x 750 (W)  
**GT1475 + [FINISH]** - 1400 (L) x 750 (W)  
**GT1675 + [FINISH]** - 1600 (L) x 750 (W)  
**GT1875 + [FINISH]** - 1800 (L) x 750 (W)

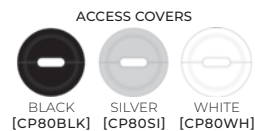

25mm Rectangular top with 2 x 80mm Ø cut-outs / Non-handed / Available in CN Exclusive laminates, Anthracite, Stone Grey & White

**NOTE: Access covers must be ordered separately / 80mmØ cut-out fits DOT Evo power set**

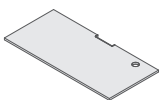

Right hand side shown

**80 Ø CUT-OUT FOR DOT EVO\* - Silver Scallop**  
**GTDSC123 + [L/R] + [FINISH]** - 1200 (L) x 750 (W)  
**GTDSC143 + [L/R] + [FINISH]** - 1400 (L) x 750 (W)  
**GTDSC163 + [L/R] + [FINISH]** - 1600 (L) x 750 (W)  
**GTDSC183 + [L/R] + [FINISH]** - 1800 (L) x 750 (W)

**80 Ø CUT-OUT FOR DOT EVO\* - Black Scallop**  
**GTDSC123B + [L/R] + [FINISH]** - 1200 (L) x 750 (W)  
**GTDSC143B + [L/R] + [FINISH]** - 1400 (L) x 750 (W)  
**GTDSC163B + [L/R] + [FINISH]** - 1600 (L) x 750 (W)  
**GTDSC183B + [L/R] + [FINISH]** - 1800 (L) x 750 (W)

25mm Rectangular top with 1 x 80mm Ø cut-out / Handed / Available in CN Exclusive laminates, Anthracite, Stone Grey & White

\*Fits DOT Evo power set  
**DE11N + [BLK/WH]**  
 (Must be ordered separately)

### LAMINATE FINISHES





**BENCHWORK COMPONENTS:**

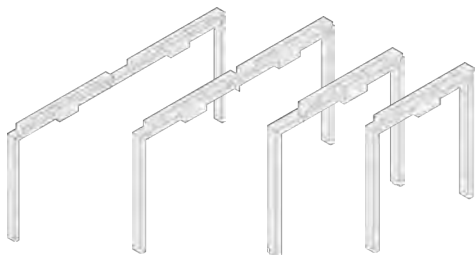

**LEG COMPONENTS**

- BW600 + [BLK/SI/WH]** - 600 (W) Leg including 1 x connector
- BW750 + [BLK/SI/WH]** - 700 (W) Leg including 1 x connector
- BW1200 + [BLK/SI/WH]** - 1200 (W) Leg including 2 x connectors
- BW1500 + [BLK/SI/WH]** - 1500 (W) Leg including 2 x connectors

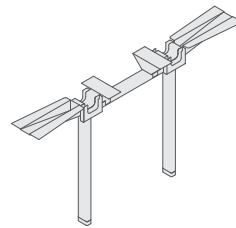

**INTERMEDIATE LEG  
BKWR600 + [BLK/SI/WH]**

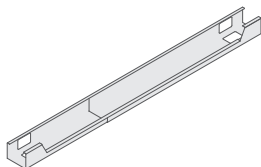

**DUAL BENCH SUPPORT BEAMS**

- BFW1800 + [BLK/SI/WH]** - 1200 - 1800mm Adjustable beam
- BFW2400 + [BLK/SI/WH]** - 1800 - 2400mm Adjustable beam

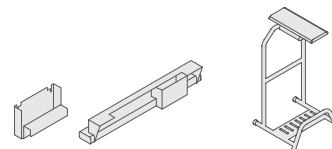

**BRACKETS**

- BFWBB90 + [BLK/SI/WH]** - Extension beam bracket
- BWSB800 + [BLK/SI/WH]** - Storage block  
(Used in conjunction with Global Managerial  
Dropped Storage)

**CPU HOLDER  
BFWCPU + [BLK/SI/WH]**



FLEXIBLE, ADJUSTABLE, INFINITELY PRACTICAL AND PRODUCTIVE **BENCHWORK**, BOASTS A COMPREHENSIVE CABLE MANAGEMENT SYSTEM.

## **BENCHWORK** GLOBAL MANAGERIAL DROPPED

### GLOBAL MANAGERIAL WORKTOPS

WORKTOP - SILVER FLIP-TOP OUTLET  
**GTMF1875 + [FINISH]**  
 1800 (L) x 750 (W)

WORKTOP - BLACK FLIP-TOP OUTLET  
**GTMF1875B + [FINISH]**  
 1800 (L) x 750 (W)

25mm Rectangular top with 1 x flip-top cable outlet in black or silver trim / Non-handed / Available in CN Exclusive Laminates, Anthracite, Stone Grey & White

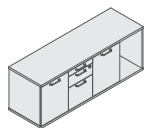
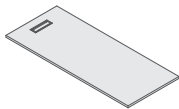

Left hand side shown

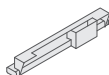

### GLOBAL MANAGERIAL DROPPED STORAGE

**GS1650 + [L/R] + [FINISH]**  
 1600 (W) x 508 (D) x 597 (H)

2 x Hinge doors / 1 x Pen & pencil drawer, 1 x standard drawer & 1 x deep filer / Open CPU compartment / Left or right handed / Available in CN Exclusive Laminates, Anthracite, Stone Grey & White

\*Use in conjunction with Benchwork storage block **BWSB800 + [BLK/SI/WH]**

### LAMINATE FINISHES





SUPALAM FINISHES



ACACIA  
[AC]



DARK EUCALYPTUS  
[DE]



NATURAL WALNUT  
[NW]



TAORMINA ASH  
[TA]



TRUE OAK  
[TO]



ANTHRACITE  
[AN]



WHITE  
[WH]

**BENCHWORK** MANAGERIAL

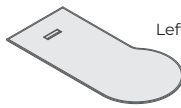

Left hand side shown

WORKTOP - SILVER CABLE OUTLET  
**CT2310 + [L/R] + [FINISH]**  
2300 (L) x 1000 (W)

WORKTOP - BLACK CABLE OUTLET  
**CT2310B + [L/R] + [FINISH]**  
2300 (L) x 1000 (W)

22mm Supalam top with reverse chamfered edge / Flip-top cable outlet / Left or right handed / Available in CN Exclusive Supalam finishes, Anthracite & White

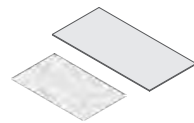

EXTENSION TOPS  
**CTR112 + [FINISH]** - 1250 (L) x 600 (W)  
**GTR110 + [FINISH]** - 1000 (L) x 600 (W)

22mm Supalam top with reverse chamfered edge / Non-handed / Available in CN Exclusive Supalam finishes, Anthracite & White



**ONE UP**, IS DESIGNED TO DELIVER WORKHORSE FUNCTIONALITY AND PRODUCTIVITY WITHOUT COMPROMISING ON STYLE.

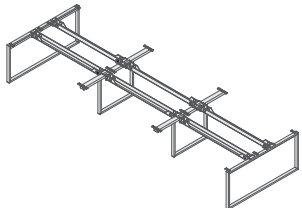

### **ONE UP** LEG STRUCTURES

#### 6-WAY DUAL BENCH

**ODU4215** + [AN/BLK/WH] - 4200 (L) x 1510 (W) x 700 (H)

**ODU4815** + [AN/BLK/WH] - 4800 (L) x 1510 (W) x 700 (H)

1400 (L) & 1600 (L) Workspace options / Rectangular leg profile / 2 x Recessed intermediate legs / Available in Anthracite [AN], Black [BLK] or White [WH]

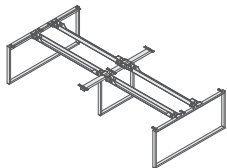

#### 4-WAY DUAL BENCH

**ODU2815** + [AN/BLK/WH] - 2800 (L) x 1510 (W) x 700 (H)

**ODU3215** + [AN/BLK/WH] - 3200 (L) x 1510 (W) x 700 (H)

1400 (L) & 1600 (L) Workspace options / Rectangular leg profile / 1 x Recessed intermediate leg / Available in Anthracite [AN], Black [BLK] or White [WH]

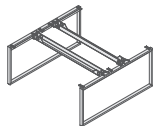

#### 2-WAY DUAL BENCH

**ODU1415** + [AN/BLK/WH] - 1400 (L) x 1510 (W) x 700 (H)

**ODU1615** + [AN/BLK/WH] - 1600 (L) x 1510 (W) x 700 (H)

1400 (L) & 1600 (L) Workspace options / Rectangular leg profile / Available in Anthracite [AN], Black [BLK] or White [WH]

### **ONE UP** SINGLE DESK

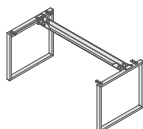

#### FRAME

**ODU1475** + [AN/BLK/WH] - 1400 (L) x 750 (W) x 700 (H)

**ODU1675** + [AN/BLK/WH] - 1600 (L) x 750 (W) x 700 (H)

**ODU1875** + [AN/BLK/WH] - 1800 (L) x 750 (W) x 700 (H)

1400 (L), 1600 (L) & 1800 (L) Workspace options / Rectangular leg profile / Available in Anthracite [AN], Black [BLK] or White [WH]



LAMINATE FINISHES

-  ACACIA [AC]
-  DARK EUCALYPTUS [DE]
-  NATURAL WALNUT [NW]
-  TAORMINA ASH [TA]
-  TRUE OAK [TO]
-  ANTHRACITE [AN]
-  STONE GREY [SG]
-  WHITE [WH]

**GLOBAL WORKTOPS**

**POWER GAP - SILVER SCALLOP**  
**GTSC143 + [FINISH]** - 1400 (L) x 750 (W)  
**GTSC163 + [FINISH]** - 1600 (L) x 750 (W)

**POWER GAP - BLACK SCALLOP**  
**GTSC143B + [FINISH]** - 1400 (L) x 750 (W)  
**GTSC163B + [FINISH]** - 1600 (L) x 750 (W)

25mm Rectangular top with power gap in black or silver trim / Non-handed / Available in CN Exclusive laminates, Anthracite, Stone Grey & White

**2 x 80mm Ø CUT-OUTS**  
**GT1475 + [FINISH]** - 1400 (L) x 750 (W)  
**GT1675 + [FINISH]** - 1600 (L) x 750 (W)  
**GT1875 + [FINISH]** - 1800 (L) x 750 (W)

25mm Rectangular top with 2 x 80mm Ø cut-outs / Non-handed / Available in CN Exclusive laminates, Anthracite, Stone Grey & White

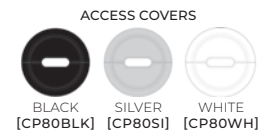

**NOTE: Access covers must be ordered separately / 80mmØ cut-out fits DOT Evo power set**

**80 Ø CUT-OUT FOR DOT EVO\* - Silver Scallop**      **80 Ø CUT-OUT FOR DOT EVO\* - Black Scallop**  
**GTDSC143 + [L/R] + [FINISH]** - 1400 (L) x 750 (W)      **GTDSC143B + [L/R] + [FINISH]** - 1400 (L) x 750 (W)  
**GTDSC163 + [L/R] + [FINISH]** - 1600 (L) x 750 (W)      **GTDSC163B + [L/R] + [FINISH]** - 1600 (L) x 750 (W)

25mm Rectangular top with 1 x 80mm Ø cut-out / Handed / Available in CN Exclusive laminates, Anthracite, Stone Grey & White

\*Fits DOT Evo power set  
**DE11N + [BLK/WH]**  
 (Must be ordered separately)

Right hand side shown

Images shown for display purposes only. Actual finishes may vary.



**URBAN**, A SIMPLE AND PRACTICAL DESKING SOLUTION WITH AN UNCLUTTERED AESTHETIC. COST-EFFECTIVE AND FUNCTIONAL WITH A VARIETY OF OPTIONS TO CREATE AN INSPIRING OFFICE.

### GLOBAL WORKTOPS

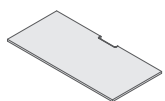

**POWER GAP - SILVER SCALLOP**  
**GTSC143 + [FINISH]** - 1400 (L) x 750 (W)  
**GTSC163 + [FINISH]** - 1600 (L) x 750 (W)

25mm Rectangular top with power gap in black or silver trim / Non-handed / Available in CN Exclusive laminates, Anthracite, Stone Grey & White

**POWER GAP - BLACK SCALLOP**  
**GTSC143B + [FINISH]** - 1400 (L) x 750 (W)  
**GTSC163B + [FINISH]** - 1600 (L) x 750 (W)

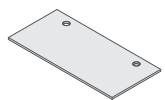

**2 x 80mm Ø CUT-OUTS**  
**GT1475 + [FINISH]** - 1400 (L) x 750 (W)  
**GT1675 + [FINISH]** - 1600 (L) x 750 (W)  
**GT1875 + [FINISH]** - 1800 (L) x 750 (W)

25mm Rectangular top with 2 x 80mm Ø cut-outs / Non-handed / Available in CN Exclusive laminates, Anthracite, Stone Grey & White

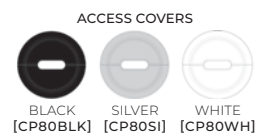

**NOTE: Access covers must be ordered separately / 80mmØ cut-out fits DOT Evo power set**

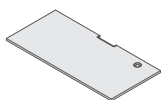

Right hand side shown

**80 Ø CUT-OUT FOR DOT EVO\* - Silver Scallop**  
**GTDSC143 + [L/R] + [FINISH]** - 1400 (L) x 750 (W)  
**GTDSC163 + [L/R] + [FINISH]** - 1600 (L) x 750 (W)

**80 Ø CUT-OUT FOR DOT EVO\* - Black Scallop**  
**GTDSC143B + [L/R] + [FINISH]** - 1400 (L) x 750 (W)  
**GTDSC163B + [L/R] + [FINISH]** - 1600 (L) x 750 (W)

25mm Rectangular top with 1 x 80mm Ø cut-out / Handed / Available in CN Exclusive laminates, Anthracite, Stone Grey & White

\*Fits DOT Evo power set  
**DE11N + [BLK/WH]**  
 (Must be ordered separately)

### LAMINATE FINISHES



ACACIA [AC]



DARK EUCALYPTUS [DE]



NATURAL WALNUT [NW]



TAORMINA ASH [TA]



TRUE OAK [TO]



ANTHRACITE [AN]



STONE GREY [SG]



WHITE [WH]





## URBAN LEG STRUCTURES

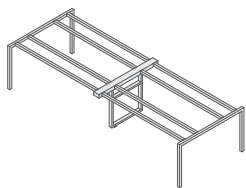

4-WAY DUAL BENCH  
**UBD2815 + [BLK/SI/WH]**  
 2800 (L) x 1510 (W) x 700 (H)

**UBD3215 + [BLK/SI/WH]**  
 3200 (L) x 1510 (W) x 700 (H)

1400 (L) & 1600 (L) Workspace options / 1 x Recessed intermediate leg / Available in Black [BLK], Silver [SI] or White [WH]

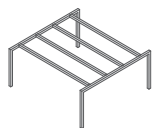

2-WAY DUAL BENCH  
**UBD1415 + [BLK/SI/WH]**  
 1400 (L) x 1510 (W) x 700 (H)

**UBD1615 + [BLK/SI/WH]**  
 1600 (L) x 1510 (W) x 700 (H)

1400 (L) & 1600 (L) Workspace options / Available in Black [BLK], Silver [SI] or White [WH]

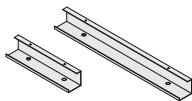

OPTIONAL CABLE TRAYS  
**UBP450 + [BLK/SI/WH]**  
 450 (L) 90 (W) x 90 (H)

**UBP900 + [BLK/SI/WH]**  
 900 (L) 90 (W) x 90 (H)

Available in Black [BLK], Silver [SI] or White [WH]



**URBAN**, A SIMPLE AND PRACTICAL DESKING SOLUTION WITH AN UNCLUTTERED AESTHETIC. COST-EFFECTIVE AND FUNCTIONAL WITH A VARIETY OF OPTIONS TO CREATE AN INSPIRING OFFICE SPACE.

### URBAN LEG STRUCTURES

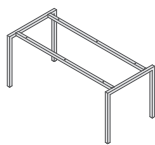

**SINGLE DESK**  
**UB1475 + [BLK/SI/WH]**  
 1400 (L) x 750 (W) x 700 (H)

**UB1675 + [BLK/SI/WH]**  
 1600 (L) x 750 (W) x 700 (H)

**UB1875 + [BLK/SI/WH]**  
 1800 (L) x 750 (W) x 700 (H)

1400 (L), 1600 (L) & 1800 (L) Workspace options / Square leg profile / Available in Black [BLK], Silver [SI] or White [WH]

### URBAN COMPONENTS:



**90° STORAGE BRACKET**  
**BR90**

Standard hardware for joining extension tops to Global storage

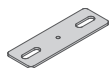

**JOINING PLATE**  
**UJP96**  
 140 (L) x 44 (W) x 3 mm

Standard hardware for joining extension tops to Global worktops

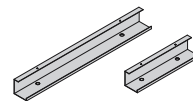

**OPTIONAL CABLE TRAYS**  
**UBP450 + [BLK/SI/WH]** - 450 (L)  
 90 (W) x 90 (H)  
**UBP900 + [BLK/SI/WH]** - 900 (L)  
 90 (W) x 90 (H)

Available in Black [BLK], Silver [SI] or White [WH]



LAMINATE FINISHES

-  ACACIA [AC]
-  DARK EUCALYPTUS [DE]
-  NATURAL WALNUT [NW]
-  TAORMINA ASH [TA]
-  TRUE OAK [TO]
-  ANTHRACITE [AN]
-  STONE GREY [SG]
-  WHITE [WH]

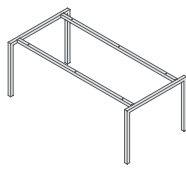

**URBAN LEG STRUCTURE**

**MANAGERIAL DESK**  
**UB1890 + [BLK/SI/WH]**  
 1800 (L) x 900 (W) x 700 (H)

Available in Black [BLK], Silver [SI] pr White [WH]

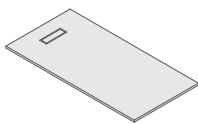

**MANAGERIAL WORKTOP** - 1 x FLIP-TOP CABLE OUTLET  
**GTMF1890 + [FINISH]** - Silver cable outlet  
**GTMF1890B + [FINISH]** - Black cable outlet  
 1800 (L) x 900 (W)

25mm Rectangular top / Available in CN Exclusive laminates, Anthracite, Stone Grey & White

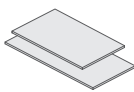

**EXTENSION TOPS**  
**GT112 + [FINISH]** - 1250 (L) x 600 (W)  
**GT110 + [FINISH]** - 1000 (L) x 600 (W)

25mm Extension tops / Non-handed / Available in CN Exclusive Laminates, Anthracite, Stone Grey & White

Images shown for display purposes only. Actual finishes may vary.



**URBAN LITE**, AN OFFICE DESK RANGE THAT RELIES ON THE PEDESTAL FOR SUPPORT, MAKING IT AN EXCEPTIONALLY AFFORDABLE RANGE.

### GLOBAL WORKTOPS

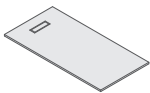

**FLIP-TOP CABLE OUTLET - SILVER**  
**GTMF1475 + [FINISH]**  
 1400 (L) x 750 (W)

**GTMF1675 + [FINISH]**  
 1600 (L) x 750 (W)

**GTMF1875 + [FINISH]**  
 1800 (L) x 750 (W)

25mm Rectangular top with flip-top cable outlet in black or silver / Non-handed / Available in CN  
 Exclusive Laminates, Anthracite, Stone Grey & White

**FLIP-TOP CABLE OUTLET - BLACK**  
**GTMF1475B + [FINISH]**  
 1400 (L) x 750 (W)

**GTMF1675B + [FINISH]**  
 1600 (L) x 750 (W)

**GTMF1875B + [FINISH]**  
 1800 (L) x 750 (W)

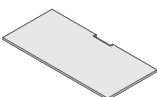

**POWER GAP - SILVER SCALLOP**  
**GTSC143 + [FINISH]** - 1400 (L) x 750 (W)  
**GTSC163 + [FINISH]** - 1600 (L) x 750 (W)  
**GTSC183 + [FINISH]** - 1800 (L) x 750 (W)

25mm Rectangular top with power gap in black or silver trim / Non-handed / Available in CN  
 Exclusive Laminates, Anthracite, Stone Grey & White

**POWER GAP - BLACK SCALLOP**  
**GTSC143B + [FINISH]** - 1400 (L) x 750 (W)  
**GTSC163B + [FINISH]** - 1600 (L) x 750 (W)  
**GTSC183B + [FINISH]** - 1800 (L) x 750 (W)

### LAMINATE FINISHES



ACACIA  
 [AC]



DARK EUCALYPTUS  
 [DE]



NATURAL WALNUT  
 [NW]



TAORMINA ASH  
 [TA]



TRUE OAK  
 [TO]



ANTHRACITE  
 [AN]



STONE GREY  
 [SC]



WHITE  
 [WH]



**URBAN COMPONENTS:**

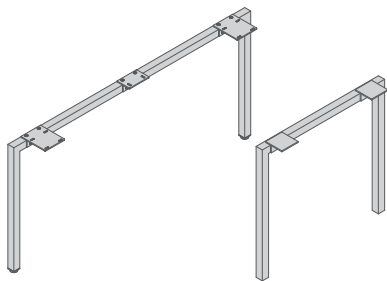

**LEG COMPONENTS**  
**UBL1510 + [BLK/SI//WH]** - 1510 (W) Leg incl. 3 x connectors  
**UBL750 + [BLK/SI//WH]** - 750 (W) Leg incl. 2 x connector

Available in Black [BLK], Silver [SI] or White [WH]

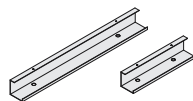

**OPTIONAL CABLE TRAYS**  
**UBP900 + [BLK/SI//WH]** - 900 (L) x 90 (W) x 90 (H)  
**UBP450 + [BLK/SI//WH]** - 450 (L) x 90 (W) x 90 (H)

Available in Black [BLK], Silver [SI] or White [WH]

**URBAN LITE**, AN OFFICE DESK RANGE THAT RELIES ON THE PEDESTAL FOR SUPPORT, MAKING THIS AN EXCEPTIONAL AFFORDABLE PRODUCT.



**URBAN LITE** DESK HEIGHT PEDESTALS

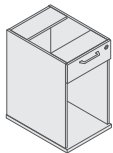

**UBL700 + [FINISH]**  
400 (W) x 550 (D) x 700 (H)

Central locking / 1 x Floating pen & pencil tray, 1 x standard drawer & 1 x CPU compartment / Carcass in paired finish with wood grain drawer front / Available in CN Exclusive laminates paired with anthracite, black, stone grey or white



**UBL701 + [L/R] + [FINISH]**  
400 (W) x 550 (D) x 700 (H)

Central locking / 1 x Floating pen & pencil tray, 1 x standard drawer & 1 x hinge door / Carcass in paired finish with wood grain door & drawer fronts / Available in CN Exclusive laminates paired with anthracite, black, stone grey or white



**UBL703F + [FINISH]**  
400 (W) x 550 (D) x 700 (H)

Central locking / 1 x Floating pen & pencil tray, 2 x standard drawers & 1 x deep filer / Carcass in paired finish with wood grain drawer fronts / Available in CN Exclusive laminates paired with anthracite, black, stone grey or white



**UBL704F + [FINISH]**  
400 (W) x 550 (D) x 700 (H)

Central locking / 1 x Floating pen & pencil tray, 4 x standard drawers / Carcass in paired finish with wood grain drawer fronts / Available in CN Exclusive laminates paired with anthracite, black, stone grey or white

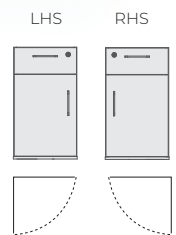

STANDARD HANDLES



BLACK  
[VG128BLK]



SILVER  
[VG128SI]

LAMINATE FINISHES



ACACIA

[ACA] / [ACB] / [ACS] / [ACW]



DARK EUCALYPTUS  
[DEA] / [DEB] / [DEW]



NATURAL WALNUT  
[NWA] / [NWB] / [NWW]



TAORMINA ASH  
[TAA] / [TAB] / [TAS] / [TAW]



TRUE OAK  
[TOA] / [TOB] / [TOW]



## URBAN LITE STORAGE

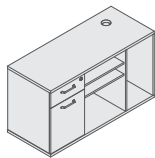

Type A shown

**OPEN PEDENZA**  
**UBL801 + [A/B] + [FINISH]**  
 1200 (W) x 500 (D) x 675 (H)

Type A or Type B / 1 x Floating pen & pencil tray / 1 x Standard drawer & 1 x hinge door / Open compartment with 1 x fixed shelves & 1 x adjustable shelf / Open CPU compartment / Carcass in paired finish with wood grain doors & drawer front / Available in CN Exclusive laminates paired with anthracite, black, stone grey or white

**\*Note: Type A - Set of drawers on left hand side**  
**Type B - Set of drawers on right hand side**

**\*Note: For CN Exclusive laminate finish only, use code [GS801A/B]**

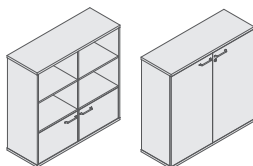

**WALL UNITS**  
**UBLP1111 + [FINISH]** - Open  
**UBL1111 + [FINISH]** - Closed  
 1100 (L) x 400 (D) x 1100 (H)

Open wall unit: 2 x hinge doors to bottom with fixed shelves / Closed wall unit: 2 x hinge doors / Carcass in paired finish with wood grain door fronts / Available in CN Exclusive laminates paired with anthracite, black, stone grey or white

**\*Note: UBLP1111 - For CN Exclusive laminate finish only, refer to Global Storage [GSP1111]**  
**UBL1111 - For CN Exclusive laminate finish only, refer to Global Storage [GS1111]**



**ADVENTURE STEEL**, THE SIMPLISTIC RECTANGULAR TUBE DESIGN OF THIS OFFICE DESK ENCOMPASSES ALL THAT IS REQUIRED TO SET UP AN OFFICE SPACE WITHOUT FUSS.

### ADVENTURE STEEL LEG STRUCTURE

22mm Top / Metal understructure in Aluminium Grey, Black, Light Grey or White painted finish / Non-handed / Includes 2 x cable outlets / Available in Barrel Oak, Folkstone Grey, Marmara Walnut, Mondego Elm & White laminates

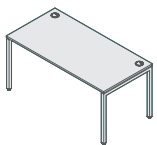

#### SINGLE DESKS

**AVS001 + [FINISH]** - Aluminium Grey  
**AVSB001 + [FINISH]** - Black  
**AVSG001 + [FINISH]** - Light Grey  
**AVSW001 + [FINISH]** - White  
 1800 (L) x 750 (W) x 722 (H)

**AVS002 + [FINISH]** - Aluminium Grey  
**AVSB002 + [FINISH]** - Black  
**AVSG002 + [FINISH]** - Light Grey  
**AVSW002 + [FINISH]** - White  
 1500 (L) x 750 (W) x 722 (H)

**AVS003 + [FINISH]** - Aluminium Grey  
**AVSB003 + [FINISH]** - Black  
**AVSG003 + [FINISH]** - Light Grey  
**AVSW003 + [FINISH]** - White  
 1200 (L) x 750 (W) x 722 (H)

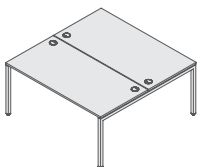

#### DUAL BENCH DESKS

**AVS1815 + [FINISH]** - Aluminium Grey  
**AVSB1815 + [FINISH]** - Black  
**AVSG1815 + [FINISH]** - Light Grey  
**AVSW1815 + [FINISH]** - White  
 1800 (L) x 1510 (W) x 722 (H)

**AVS1515 + [FINISH]** - Aluminium Grey  
**AVSB1515 + [FINISH]** - Black  
**AVSG1515 + [FINISH]** - Light Grey  
**AVSW1515 + [FINISH]** - White  
 1500 (L) x 1510 (W) x 722 (H)

**AVS1215 + [FINISH]** - Aluminium Grey  
**AVSB1215 + [FINISH]** - Black  
**AVSG1215 + [FINISH]** - Light Grey  
**AVSW1215 + [FINISH]** - White  
 1200 (L) x 1510 (W) x 722 (H)

#### FRAME COLOURS



ALUMINIUM GREY



BLACK



LIGHT GREY



WHITE





## ADVENTURE STEEL MOBILE PEDISTALS

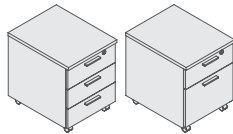

**AV705 + [FINISH]** - 3 x Standard drawers  
**AV706 + [FINISH]** - 1 x Standard drawer, 1 x deep filer  
 400 (W) x 516 (D) x 540 (H)

Available in Barrel Oak, Folkstone Grey, Marmara Walnut, Mondego Elm & White or Mondego Elm paired with Folkstone Grey laminate

\*When pairing: top, bottom & drawer fronts will be in wood grain finish with back & sides in paired finish

## ADVENTURE STEEL STORAGE

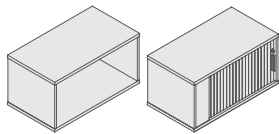

**TOP FILERS**  
**AV802 + [FINISH]** - Open compartment  
**AV803 + [FINISH]** - Roller door compartment - Silver  
 400 (W) x 755 (D) x 382 (H)

Used in conjunction with multi storage bench pedestals / Available in Barrel Oak, Folkstone Grey, Marmara Walnut, Mondego Elm & White or Mondego Elm paired with Folkstone Grey laminate

\*When pairing: top, bottom & sides will be in wood grain finish with back in paired finish

**BENCH PEDESTALS**  
**AV707 + [FINISH]** - 2 x Standard drawers, 1 x deep filer  
**AV714 + [FINISH]** - 4 x Standard drawers  
 400 (W) x 755 (D) x 700 (H)

Excluding tops / Available in Barrel Oak, Folkstone Grey, Marmara Walnut, Mondego Elm & White or Mondego Elm paired with Folkstone Grey laminate

\*When pairing: bottom & drawer fronts will be in wood grain finish with back & sides in paired finish

**SLIDING DOOR END CABINET**  
**AVS1535 + [FINISH]**  
 1510 (W) x 420 (D) x 1082 (H)

Includes timber shelves / Available in Barrel Oak, Folkstone Grey, Marmara Walnut, Mondego Elm & White or Mondego Elm paired with Folkstone Grey laminate

\*When pairing: top, bottom, shelves & door fronts will be in wood grain finish with back & sides in paired finish

### LAMINATE FINISHES



BARREL OAK  
[BO]



FOLKSTONE GREY  
[FG]



MARMARA WALNUT  
[MW]



MONDEGO ELM  
[ME] / [MEG]



WHITE  
[WH]

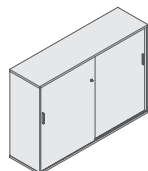
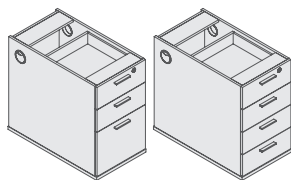

## ADVENTURE STEEL STORAGE

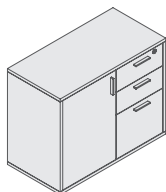

Right hand side shown

**HINGE DOOR PEDENZA**  
**AV801 + [L/R] + [FINISH]**  
 900 (W) x 450 (D) x 722 (H)

Available in LHS (Drawers on left of door) or RHS (Drawers on right of door) / 2 x Standard drawers, 1 x deep filer & 1 x hinge door / Available in Barrel Oak, Folkstone Grey, Marmara Walnut, Mondego Elm & White or Mondego Elm paired with Folkstone Grey laminates

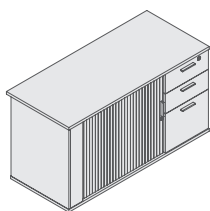

**ROLLER DOOR PEDENZA**  
**AV803A + [FINISH]\* - Type A**  
**AV803B + [FINISH] - Type B**  
 1300 (W) x 600 (D) x 722 (H)  
 Not shown\*

**AV010 + [FINISH] - Optional timber shelf**  
 716 (W) x 430 (D) x 16mm

Type A or Type B / 2 x Standard drawers & 1 x deep filer / Silver roller door / Optional timber shelf / Available in Barrel Oak, Folkstone Grey, Marmara Walnut, Mondego Elm & White or Mondego Elm paired with Folkstone Grey laminates

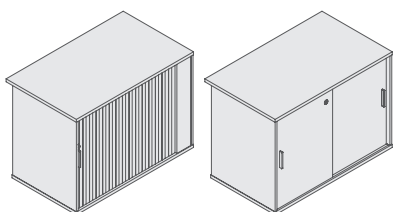

**CREDENZA'S**  
**AV810 + [FINISH] - Roller door excluding optional shelf**  
**AV811 + [FINISH] - Sliding door including shelf**  
 1000 (W) x 600 (D) x 722 (H)

**AV010 + [FINISH] - Optional timber shelf**  
 716 (W) x 430 (D) x 16mm

Includes top / Roller & sliding door options / Optional timber shelf / Available in Barrel Oak, Folkstone Grey, Marmara Walnut, Mondego Elm & White or Mondego Elm paired with Folkstone Grey laminates

\*When pairing pedenzas & credenzas: Top, bottom, shelves, door and drawer fronts & side cleats will be in wood grain finish with back & sides in paired finish

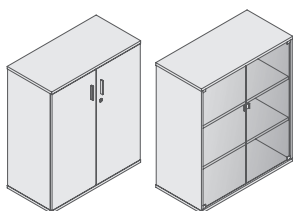

**HINGE DOOR CABINETS**  
**AV8045 + [FINISH] - Solid doors**  
**AV8045G + [FINISH] - Glass doors**  
 900 (W) x 450 (D) x 1082 (H)

3-Tier includes 2 x adjustable shelves / Solid wood grain or clear glass door options / Available in Barrel Oak, Folkstone Grey, Marmara Walnut, Mondego Elm & White or Mondego Elm paired with Folkstone Grey laminates

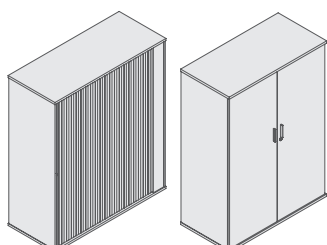

**SYSTEMS CABINETS**  
**AV821 + [FINISH] - Roller door**  
 1300 (W) x 550 (D) x 1540 (H)

**AV822 + [FINISH] - Hinge doors**  
 1100 (W) x 550 (D) x 1540 (H)

**AV021 + [FINISH] - Optional timber shelf**  
 1065 (W) x 450 (D) x 22mm

Roller or solid wood grain door options / Optional timber shelf / Available in Barrel Oak, Folkstone Grey, Marmara Walnut, Mondego Elm & White or Mondego Elm paired with Folkstone Grey laminates

\*When pairing hinge door or systems cabinets: Top, bottom, shelves, door fronts & side cleats will be in wood grain finish with back & sides in paired finish

### LAMINATE FINISHES



BARREL OAK  
[BO]



FOLKSTONE GREY  
[FG]



MARMARA WALNUT  
[MW]



MONDEGO ELM  
[ME]/[MEG]



WHITE  
[WH]



## ADVENTURE STEEL MANAGERIAL

22mm Top / Metal understructure in Aluminium Grey, Black, Light Grey or White painted finish / Non-handed / Includes 2 x cable outlets / Available in Barrel Oak, Folkstone Grey, Marmara Walnut, Mondego Elm & White laminates

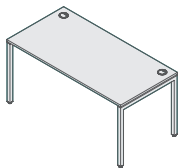

MANAGERIAL DESK  
**AVS1890 + [FINISH]** - Aluminium Grey  
**AVSB1890 + [FINISH]** - Black  
**AVSG1890 + [FINISH]** - Light Grey  
**AVSW1890 + [FINISH]** - White  
 1800 (L) x 900 (W) x 722 (H)



MODESTY PANEL - Including brackets  
**AMPL1500 + [FINISH]** - 16mm

### FRAME COLOURS



ALUMINIUM GREY



BLACK



LIGHT GREY



WHITE

### DESK EXTENSION

22mm Top / Metal understructure in Aluminium Grey, Black, Light Grey or White painted finish / Non-handed / Available in Barrel Oak, Folkstone Grey, Marmara Walnut, Mondego Elm & White laminates

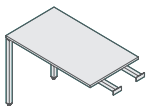

**AVS1050 + [FINISH]** - Aluminium Grey  
**AVSB1050 + [FINISH]** - Black  
**AVSG1050 + [FINISH]** - Light Grey  
**AVSW1050 + [FINISH]** - White  
 1050 (L) x 600 (W) x 722 (H)

**AVS750 + [FINISH]** - Aluminium Grey  
**AVSB750 + [FINISH]** - Black  
**AVSG750 + [FINISH]** - Light Grey  
**AVSW750 + [FINISH]** - White  
 750 (L) x 600 (W) x 722 (H)



**CALL ME**, THIS 4<sup>TH</sup> GENERATION SYSTEM MADE UP OF POLE LEGS, STORAGE AND DESKTOPS CREATE A WELL-BALANCED OFFICE DESK SOLUTION.

### CALL ME WORKTOPS

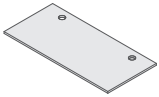

2 x 80mm Ø CUT-OUTS  
**CMT1275 + [FINISH]** - 1200 (L) x 750 (W)  
**CMT1475 + [FINISH]** - 1400 (L) x 750 (W)

25mm Rectangular top with 2 x 80mm Ø cut-outs / Non-handed / Available in CN Exclusive Laminates, Anthracite, Stone Grey & White

**NOTE:** Access covers must be ordered separately / 80mm Ø cut-out fits DOT Evo power set

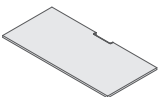

**POWER GAP - SILVER SCALLOP**  
**CMTSC123 + [FINISH]** - 1200 (L) x 750 (W)  
**CMTSC143 + [FINISH]** - 1400 (L) x 750 (W)

25mm Rectangular tops with power gap in black or silver trim / Non-handed / Available in CN Exclusive Laminates, Anthracite, Stone Grey & White

**POWER GAP - BLACK SCALLOP**  
**CMTSC123B + [FINISH]** - 1200 (L) x 750 (W)  
**CMTSC143B + [FINISH]** - 1400 (L) x 750 (W)

#### ACCESS COVERS



#### LAMINATE FINISHES





DON'T FORGET YOUR **STORAGE:**

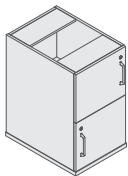

**GLOBAL SHARED PEDISTAL**

**GS713 + [FINISH]**  
400 (W) x 550 (D) x 700 (H)

2 x Hinge doors / Central locking / Available in CN Exclusive Laminates, Anthracite, Black, Stone Grey & White laminates

\*NOTE: Handles to be ordered seperately  
\*Available in Black [VG128BLK] & Silver [VG128SI]

STANDARD HANDLES



BLACK  
[VG128BLK]

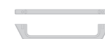

SILVER  
[VG128SI]

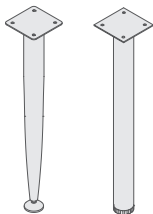

**CALL ME LEGS**

POLE LEGS  
**TL700 + [BLK/SI/WH]** - Tapered  
**WS700F + [BLK/SI/WH]** - Straight

Tapered or straight pole leg options / Available in Black [BLK], Silver [SI] or White [WH]

CALL ME **COMPONENTS:**



**90° STORAGE BRACKET**  
**BR90**

Standard hardware for joining extension tops & storage items to worktops

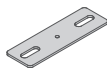

**EXTENSION TOP JOINING PLATE**  
**UJP96**

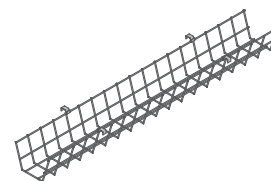

**WIRE BASKET - INCLUDING CLIPS**  
**WB900SI**  
900 (L) x 130 (D) x 85 (H)



**XPRESS-ME**, A MODERN OFFICE DESKING RANGE WITH WARM WOOD GRAIN TOPS THAT REST ON TWO-TONE STORAGE ITEMS.

**XPRESS-ME** DESK WITH LONG MODESTY

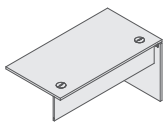

Right hand side shown

XPM1431 + [L/R] + [FINISH] - 1400 (L) x 750 (W) x 725 (H)  
 XPM1631 + [L/R] + [FINISH] - 1600 (L) x 750 (W) x 725 (H)

25mm Wood grain top with fold up panel leg & full modesty in paired finish / Attaches to pedestal base unit / Left or right handed / Storage attaches to right side on right handed & left side on left handed / Available in CN Exclusive laminates paired with anthracite, black, stone grey or white

**NOTE:** Access covers must be ordered separately / 80mmØ cut-out fits DOT Evo power set

**XPRESS-ME** PEDESTAL BASE UNIT

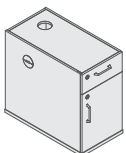

Right hand side shown

XPMB707 + [L/R] + [FINISH]  
 400 (W) x 750 (D) x 700 (H)

1 x Floating pen & pencil tray, 1 x standard drawer & 1 x hinged door / Left or right handed / Storage attaches to right side on right handed & left side on left handed / Available in CN Exclusive laminates paired with anthracite, black, stone grey or white

**NOTE:** Handles must be ordered separately

**GLOBAL** TOP BOX

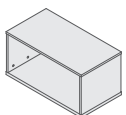

GSB750 + [FINISH]  
 400 (W) x 750 (D) x 371 (H)

Used in conjunction with Xpress-Me Pedestal Base Unit / Non-handed / Available in CN Exclusive laminates, black or white

ACCESS COVERS



BLACK  
 [CP80BLK]



SILVER  
 [CP80SI]



WHITE  
 [CP80WH]

LHS

RHS

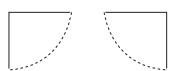
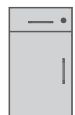

STANDARD HANDLES



BLACK  
 [VG128BLK]



SILVER  
 [VG128SI]



## XPRESS-ME DESK WITH SHORT MODESTY

### RECTANGULAR DESK

XPMB1631S + [L/R] + [FINISH] - 1600 (L) x 750 (W) x 725 (H)  
 XPMB1831S + [L/R] + [FINISH] - 1800 (L) x 750 (W) x 725 (H)

25mm Wood grain top with fold up panel leg & short modesty in paired finish / Pedestal fits under desktop / Left or right handed / Storage attaches to right side on right handed & left side on left handed / Available in CN Exclusive laminates paired with anthracite, black, stone grey or white

**NOTE:** Access covers must be ordered separately / 80mm Ø cut-out fits DOT Evo power set

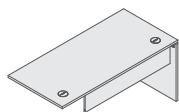

Right hand side shown

### XPRESS-ME PEDESTAL BASE UNIT

XPMB707 + [L/R] + [FINISH]  
 400 (W) x 750 (D) x 700 (H)

1 x Floating pen & pencil tray, 1 x standard drawer & 1 x hinged door / Left or right handed / Storage fits under desktop to right side on right handed & left side on left handed / Available in CN Exclusive laminates paired with anthracite, black, stone grey or white

**NOTE:** Handles must be ordered separately

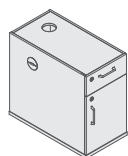

Right hand side shown

#### LAMINATE FINISHES



ACACIA

[AC] / [ACA] / [ACS] / [ACW]



DARK EUCALYPTUS

[DE] / [DEA] / [DEB] / [DEW]



NATURAL WALNUT

[NW] / [NWA] / [NWB] / [NWW]



TAORMINA ASH

[TA] / [TAA] / [TAS] / [TAW]



TRUE OAK

[TO] / [TOA] / [TOB]



## **XPRESS-ME** RECTANGULAR DESK

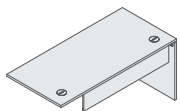

Right hand side shown

### RECTANGULAR DESK

**XPM1631S + [L/R] + [FINISH]** - 1600 (L) x 750 (W) x 725 (H)  
**XPM1831S + [L/R] + [FINISH]** - 1800 (L) x 750 (W) x 725 (H)

25mm Wood grain top with fold up panel leg & short modesty in paired finish / Fits to dropped L-Extension / Left or right handed / Storage attaches to right side on right handed & left side on left handed / Available in CN Exclusive laminates paired with anthracite, black, stone grey or white

**NOTE: Access covers must be ordered seperately / 80mm Ø cut-out fits DOT Evo power set**

## **XPRESS-ME** DROPPED L-EXTENSION

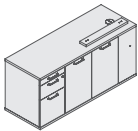

Left hand side shown

### XPM1505 + [L/R] + [FINISH]

1500 (W) x 550 (D) x 675 (H)

1 x Hinge door & CPU compartment / 1 x Pen & pencil drawer, 1 x standard drawer & 1 x deep filer / Left or right handed / Storage fits to the right on right handed and to the left on left handed / Brackets included / Available in CN Exclusive laminates paired with anthracite, black, stone grey or white

## **XPRESS-ME** WALL UNIT

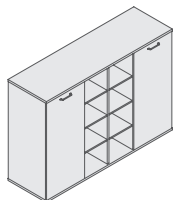

### XPM1845 + [FINISH]

1800 (W) x 450 (D) x 1250 (H)

2 x Hinge doors with open compartment with adjustable shelves / Available in CN Exclusive laminates paired with anthracite, black, stone grey or white

\*When pairing: door fronts will be in wood grain finish with paired carcass

### LAMINATE FINISHES







## **XPRESS-ME** RECTANGULAR DESK

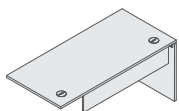

Right hand side shown

### RECTANGULAR DESK

**XPM1631S + [L/R] + [FINISH]** - 1600 (L) x 750 (W) x 725 (H)  
**XPM1831S + [L/R] + [FINISH]** - 1800 (L) x 750 (W) x 725 (H)

25mm Wood grain top with fold up panel leg & short modesty in paired finish / Fits on dropped pedestal / Left or right handed / Storage attaches to right side on right handed & left side on left handed / Available in CN Exclusive laminates paired with anthracite, black, stone grey or white

**NOTE:** Access covers must be ordered separately / 80mm Ø cut-out fits DOT Evo power set

## **XPRESS-ME** DROPPED PEDESTAL



Right hand side shown

### XPMD705 + [L/R] + [FINISH]

700 (W) x 750 (D) x 675 (H)

\*Height excludes dropped storage block

1 x Floating pen & pencil tray, 3 x standard drawers & 1 x open compartment with adjustable shelf / Left or right handed / Available in CN Exclusive laminates paired with anthracite, black, stone grey or white

**NOTE:** Handles must be ordered separately

## **XPRESS-ME** STORAGE

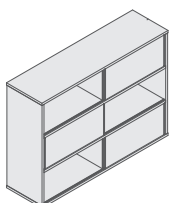

### WALL UNIT

**XPM1645 + [FINISH]**

1600 (W) x 450 (D) x 1166 (H)

25mm Laminate carcass / 3-Tier bookcase with open compartments / 3 x Sliding doors available in CN Exclusive laminates paired with anthracite, black, stone grey or white



### MOVABLE PEDESTAL

**UQ4235 + [FINISH]**

428 (W) x 396 (D) x 347 (H)

2 x Standard drawers with 30mm finger gap / Available in CN Exclusive laminates, Anthracite, Black, Stone Grey & White

### ACCESS COVERS



BLACK  
[CP80BLK]



SILVER  
[CP80SI]



WHITE  
[CP80WH]

### STANDARD HANDLES



BLACK  
[VG128BLK]



SILVER  
[VG128SI]

Images shown for display purposes only. Actual finishes may vary.



**XPRESS**, A MARK OF THE INDUSTRY FOR SIMPLISTIC DESIGN AND EXTREMELY QUICK INSTALLATION. COMPLETE RECTANGULAR DESKS ARE PAIRED WITH EXTENSIONS TOPS AND STORAGE, TO CREATE A VERSATILE AND COMPACT RANGE.

### **XPRESS** RECTANGULAR DESKS

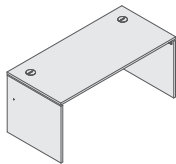

- XP143 + [FINISH] - 1400 (L) x 750 (W) x 725 (H)
- XP153 + [FINISH] - 1500 (L) x 750 (W) x 725 (H)
- XP163 + [FINISH] - 1600 (L) x 750 (W) x 725 (H)
- XP183 + [FINISH] - 1800 (L) x 750 (W) x 725 (H)

25mm Wood grain top with fold up panel leg & modesty in paired finish / Non-handed / Available in CN Exclusive laminates, Stone Grey & White or CN Exclusive laminates & White paired with anthracite

NOTE: Access covers must be ordered seperately / 80mm Ø cut-out fits DOT Evo power set

### **GLOBAL** EXTENSION TOPS

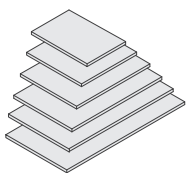

- GT104 + [FINISH] - 400 (L) x 600 (W)
- GT106 + [FINISH] - 600 (L) x 600 (W)
- GT108 + [FINISH] - 800 (L) x 600 (W)
- GT109 + [FINISH] - 900 (L) x 600 (W)
- GT110 + [FINISH] - 1000 (L) x 600 (W)
- GT112 + [FINISH] - 1250 (L) x 600 (W)

25mm Tops / Non-handed / Available in CN Exclusive laminates, Stone Grey & White

#### LAMINATE FINISHES





## XPRESS HANDED CORE DESKS

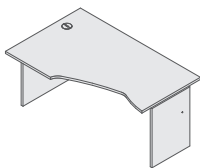

Left hand side shown

### STRAIGHT END DESK

**XP160 + [L/R] + [FINISH]** - 1600 (L) x 1000 (W) x 725 (H)

**XP180 + [L/R] + [FINISH]** - 1800 (L) x 1000 (W) x 725 (H)

25mm Wood grain top with fold up panel leg & modesty in paired finish / Left or right handed / Available in CN Exclusive laminates, Stone Grey & White or CN Exclusive laminates & White paired with anthracite

**NOTE:** Access covers must be ordered separately / 80mm Ø cut-out fits DOT Evo power set

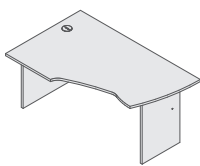

Left hand side shown

### CURVED END DESK

**XP161 + [L/R] + [FINISH]** - 1600 (L) x 1000 (W) x 725 (H)

**XP181 + [L/R] + [FINISH]** - 1800 (L) x 1000 (W) x 725 (H)

25mm Wood grain top with fold up panel leg & modesty in paired finish / Left or right handed / Available in CN Exclusive laminates, Stone Grey & White or CN Exclusive laminates & White paired with anthracite

**NOTE:** Access covers must be ordered separately / 80mm Ø cut-out fits DOT Evo power set

#### ACCESS COVERS



BLACK  
[CP80BLK]



SILVER  
[CP80SI]



WHITE  
[CP80WH]



A PANEL OFFICE DESK IN A BOX, **XPRESS LITE**, IS A MARK OF THE INDUSTRY FOR SIMPLISTIC DESIGN AND EXTREMELY QUICK INSTALLATION.

### XPRESS LITE RECTANGULAR DESKS

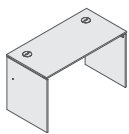

**XPL113 + [FINISH]**  
1200 (L) x 600 (W) x 716 (H)

16mm Top with fold up panel legs & modesty / Non-handed / Available in CN Exclusive laminates, Stone Grey & White or CN Exclusive laminates & White paired with anthracite

NOTE: Access covers must be ordered separately / 80mm Ø cut-out fits DOT Evo power set

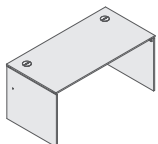

**XPL123 + [FINISH]** - 1200 (L) x 750 (W) x 716 (H)  
**XPL153 + [FINISH]** - 1500 (L) x 750 (W) x 716 (H)

16mm Top with fold up panel legs & modesty / Non-handed / Available in CN Exclusive laminates, Stone Grey & White or CN Exclusive laminates & White paired with anthracite

NOTE: Access covers must be ordered separately / 80mm Ø cut-out fits DOT Evo power set

### XPRESS LITE EXTENSION TOPS

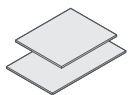

**XPL106 + [FINISH]** - 600 (L) x 500 (W)  
**XPL108 + [FINISH]** - 800 (L) x 500 (W)

16mm Top / Non-handed / Available in CN Exclusive Laminates, Anthracite, Stone Grey & White

#### ACCESS COVERS



BLACK  
[CP80BLK]



SILVER  
[CP80SI]



WHITE  
[CP80WH]

#### LAMINATE FINISHES



ACACIA  
[AC] / [ACA]

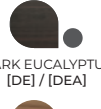

DARK EUCALYPTUS  
[DE] / [DEA]



NATURAL WALNUT  
[NW] / [NWA]



TAORMINA ASH  
[TA] / [TAA]



TRUE OAK  
[TO] / [TOA]



WHITE  
[WH] / [WHA]



ANTHRACITE  
[AN]



STONE GREY  
[SG]



## GLOBAL SLIM DESK HEIGHT PEDESTAL



**GSS733 + [FINISH]**  
300 (W) x 450 (D) x 700 (H)

1 x Floating pen & pencil tray, 2 x standard drawers & 1 x deep filer / Central locking / Available in CN Exclusive Laminates, Anthracite, Black, Stone Grey & White

**NOTE: Handles must be ordered seperately**



**GSS734 + [FINISH]**  
300 (W) x 450 (D) x 700 (H)

1 x Floating pen & pencil tray & 4 x standard drawers / Central locking / Available in CN Exclusive Laminates, Anthracite, Black, Stone Grey & White

**NOTE: Handles must be ordered seperately**

## GLOBAL SLIM MOBILE PEDESTALS



**GSS735 + [FINISH]**  
300 (W) x 450 (D) x 615 (H)

1 x Floating pen & pencil tray & 3 x standard drawers / Central locking / Available in CN Exclusive Laminates, Anthracite, Black, Stone Grey & White

**NOTE: Handles must be ordered seperately**



**GSS736 + [FINISH]**  
300 (W) x 450 (D) x 615 (H)

1 x Floating pen & pencil tray, 1 x standard drawer & 1 x deep filer / Central locking / Available in CN Exclusive Laminates, Anthracite, Black, Stone Grey & White

**NOTE: Handles must be ordered seperately**

SLIM HANDLES



BLACK  
[VG96BLK]



SILVER  
[VG96SI]



**PRIME TIME**, A RANGE OF PANEL OFFICE DESKS IN MULTIPLE CONFIGURATIONS, WITH A RANGE OF ESSENTIAL STORAGE COMPONENTS.

### PRIME TIME DESKS

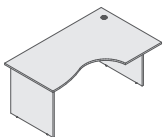

Right hand side shown

#### HANDED CORE DESKS

**PT160L + [FINISH]** - Left hand side  
**PT160R + [FINISH]** - Right hand side  
 1600 (L) x 1000 (W) x 725 (H)

**PT180L + [FINISH]** - Left hand side  
**PT180R + [FINISH]** - Right hand side  
 1800 (L) x 1000 (W) x 725 (H)

22mm Top with panel legs & modesty panel / Left or right handed / Available in American Walnut & Maple laminate

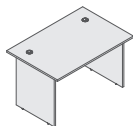

#### RECTANGULAR DESKS

**PT123 + [FINISH]** - 1200 (L) x 800 (W) x 725 (H)  
**PT153 + [FINISH]** - 1500 (L) x 800 (W) x 725 (H)

22mm Top with panel legs & modesty panel / Non-handed / Available in American Walnut & Maple laminate

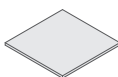

#### EXTENSION TOP

**PT106 + [FINISH]**  
 600 (L) x 600 (W)

22mm Thick / Non-handed / Available in American Walnut & Maple laminate

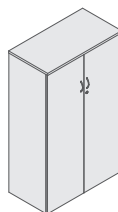

### PRIME TIME STORAGE

#### HINGE DOOR CABINET

**PS915 + [FINISH]**  
 916 (W) x 475 (D) x 1500 (H)

Includes 3 x timber shelves / Available in American Walnut & Maple laminate

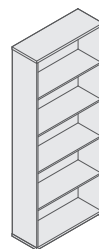

#### 5-TIER BOOKCASE

**PS805 + [FINISH]**  
 800 (W) x 304 (D) x 2000 (H)

Includes 4 x fixed shelves / Available in American Walnut & Maple laminate

#### LAMINATE FINISHES



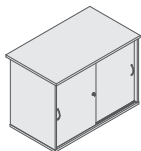

### PRIME TIME SLIDING DOOR CABINET

**PS811 + [FINISH]**  
1000 (W) x 600 (D) x 725 (H)

22mm Top / Includes timber shelf / Available in American Walnut & Maple laminate

### PRIME TIME PEDESTALS

Central locking / Available in American Walnut & Maple laminate

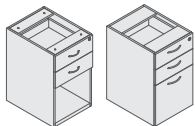

**DESK HEIGHT**  
**PS700 + [FINISH]** - 1 x Floating pen & pencil tray, 2 x standard drawers & 1 x open filer  
**PS703F + [FINISH]** - 1 x Floating pen & pencil tray, 2 x standard drawers & 1 x deep filer  
410 (W) x 500 (D) x 700 (H)



**MOBILE**  
**PS705F + [FINISH]** - 1 x Floating pen & pencil tray, 3 x standard drawers  
410 (W) x 560 (D) x 555 (H)

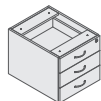

**FITTED**  
**PS709 + [FINISH]** - 1 x Floating pen & pencil tray, 3 x standard drawers  
410 (W) x 532 (D) x 400 (H)



100%  
EXCLUSIVE

THE **CELLULAR**, OFFERS MASSIVE PERSONAL STORAGE CAPACITY AND INDIVIDUAL WORKSTATION PRIVACY IN ONE PACKAGE.

## CELLULAR

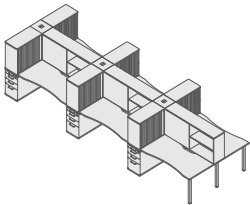

**6-WAY DUAL MODULE**  
**CEL6020D + [FINISH]**  
6000 (L) x 2000 (W)

25mm Worktops / 3 x Square legs in silver painted finish / Pedestal base units / Roller door top units / Spine top units / Power columns / Available in CN Exclusive laminates paired with white / Generic laminates [EL] paired with white

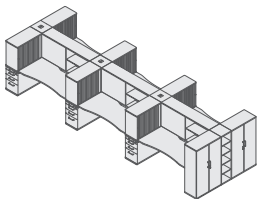

**6-WAY DUAL MODULE**  
**CEL6420D + [FINISH]**  
6400 (L) x 2000 (W)

25mm Worktops / 1 x Bookcase column & 2 x hinge door cabinets / Pedestal base units / Roller door top units / Spine top units / Power columns / Available in CN Exclusive laminates paired with white / Generic laminates [EL] paired with white

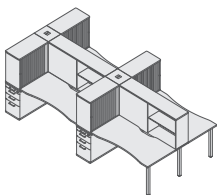

**4-WAY DUAL MODULE**  
**CEL4020D + [FINISH]**  
4000 (L) x 2000 (W)

25mm Worktops / 3 x Square legs in silver painted finish / Pedestal base units / Roller door top units / Spine top units / Power columns / Available in CN Exclusive laminates paired with white / Generic laminates [EL] paired with white

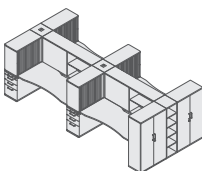

**4-WAY DUAL MODULE**  
**CEL4420D + [FINISH]**  
4400 (L) x 2000 (W)

25mm Worktops / 1 x Bookcase column & 2 x hinge door cabinets / Pedestal base units / Roller door top units / Spine top units / Power columns / Available in CN Exclusive laminates paired with white / Generic laminates [EL] paired with white

### LAMINATE FINISHES





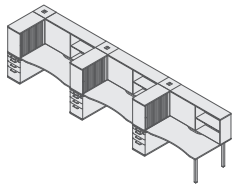

## CELLULAR

**3-WAY SIDE-BY-SIDE MODULE**  
**CEL6012S + [FINISH]**  
 6000 (L) x 1200 (W)

25mm Worktops / 3-Way side-by-side module / Pedestal base units / Roller door top units / Spine top units / Power columns / Available in CN Exclusive laminates paired with white / Generic laminates [EL] paired with white

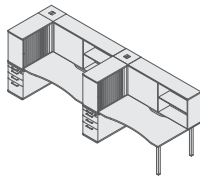

**2-WAY SIDE-BY-SIDE MODULE**  
**CEL4012S + [FINISH]**  
 4000 (L) x 1200 (W)

25mm Worktops / 2-Way side-by-side module / Pedestal base units / Roller door top units / Spine top units / Power columns / Available in CN Exclusive laminates paired with white / Generic laminates [EL] paired with white

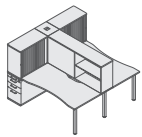

**2-WAY DUAL MODULE**  
**CEL2020D + [FINISH]**  
 2000 (L) x 2000 (W)

25mm Worktops / Pedestal base units / Roller door top units / Spine top unit / Power column / Available in CN Exclusive laminates paired with white / Generic laminates [EL] paired with white

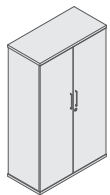

## CELLULAR CABINETS

**HINGE DOOR CABINET**  
**CEL824 + [FINISH]**  
 822 (W) x 400 (D) x 1420 (H)

Hinge door cabinets includes 3 x timber shelves / Available in CN Exclusive laminates paired with white / Generic laminates [EL] paired with white

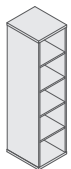

**BOOKCASE COLUMN**  
**CEL047 + [FINISH]**  
 353 (W) x 400 (D) x 1420 (H)

5 x Open bookcase column / Available in CN Exclusive laminates paired with white / Generic laminates [EL] paired with white





WFH



100%  
EXCLUSIVE

**STYLUS**, IS THE PERFECT FIT, NO MATTER WHAT STYLE YOU HAVE IN YOUR ROOM.  
OUR BEST PRICED HOME OFFICE SOLUTION.



## STYLUS DESK

**STY1470 + [B/W] + [FINISH]**  
1400 (L) x 700 (W) x 725 (H)

25mm Rectangular top / Tapered metal legs, available in Black [B] or White [W] / Available in Acacia, Natural Walnut & White laminates

LAMINATE FINISHES

ACACIA  
[AC]

NATURAL WALNUT  
[NW]

WHITE  
[WH]



100%  
EXCLUSIVE

**JENNY**, THIS DESK BRINGS A SENSE OF CALM, SIMPLICITY TO ANY HOME OFFICE. A SIMPLE SELF-ASSEMBLY SINGLE DESK, WITH ELEGANT, TAPERED SOLID OAK FEET.



LAMINATE FINISHES



NATURAL WALNUT  
[NW]



WHITE  
[WH]

**JENNY** DESK

**JN1260BNW** - Black legs paired with Natural Walnut top  
**JN1260WWH** - White legs paired with White top  
 1200 (L) x 600 (W) x 725 (H)

25mm Rectangular top / Black or white metal legs, with tapered solid Oak foot / Black metal legs paired with Natural Walnut laminate / White metal legs paired with White laminate

Images shown for display purposes only. Actual finishes may vary.





# STORAGE



**GLOBAL STORAGE**, IS A VERSATILE AND EXTENSIVE STORAGE OFFERING THAT WORKS SEAMLESSLY WITH ALL OUR FURNITURE RANGES.

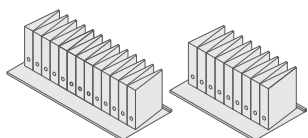

### METAL INNERS FOR GLOBAL STORAGE

#### METAL SHELVES

**SNG003** - Accommodates 13 lever arch files  
**SNG002** - Accommodates 9 lever arch files

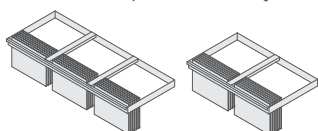

#### PULL-OUT CRADLES

**CRG1200** - Accommodates 3 x A4 hanging or foolscap left to right  
**CRG900** - Accommodates 2 x A4 hanging or foolscap left to right

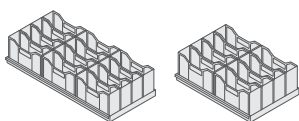

#### PULL-OUT DRAWERS

**DRG1200** - Accommodates 3 x A4 containers & 4 x deep  
**DRG900** - Accommodates 2 x A4 containers & 4 x deep

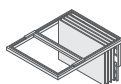

#### DROP-IN CRADLE

**FCBL** - Available in black

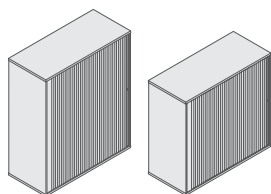

### GLOBAL SYSTEMS CABINET

#### ROLLER DOOR - SILVER

**GS821 + [FINISH]**  
 1250 (W) x 550 (D) x 1500 (H)

#### GS819 + [FINISH]

1250 (W) x 550 (D) x 1200 (H)

#### ROLLER DOOR - BLACK

**GS821 + [B] + [FINISH]**  
 1250 (W) x 550 (D) x 1500 (H)

#### GS819 + [B] + [FINISH]

1250 (W) x 550 (D) x 1200 (H)

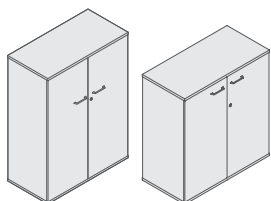

#### HINGE DOOR

**GS822 + [FINISH]**  
 1100 (W) x 550 (D) x 1500 (H)

#### GS820 + [FINISH]

1100 (W) x 550 (D) x 1200 (H)

Systemised with optional universal metal storage inners / Available in CN Exclusive Laminates, Anthracite, Black, Stone Grey & White

**NOTE: Handles must be ordered separately**

#### STANDARD HANDLES



#### LAMINATE FINISHES



ACACIA [AC]



DARK EUCALYPTUS [DE]



NATURAL WALNUT [NW]



TAORMINA ASH [TA]



TRUE OAK [TO]



ANTHRACITE [AN]



BLACK [BLK]



STONE GREY [SG]



WHITE [WH]

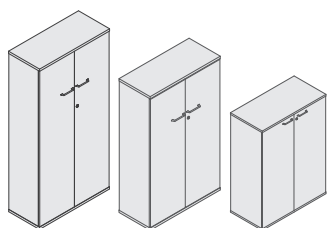

### GLOBAL HINGE DOOR FILING CABINETS

**GS918 + [FINISH]** - 900 (W) x 400 (D) x 1800 (H)

**GS915 + [FINISH]** - 900 (W) x 400 (D) x 1500 (H)

**GS911 + [FINISH]** - 900 (W) x 400 (D) x 1100 (H)

1100 (H) Includes 2 x fixed timber shelves / 1500 (H) Includes 3 x timber shelves / 1800 (H) includes 4 x fixed timber shelves / Available in CN Exclusive Laminates, Anthracite, Black, Stone Grey & White

**NOTE: Handles must be ordered separately**



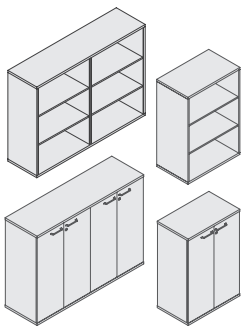

### GLOBAL BENCH END STORAGE

**BOOKCASES**  
**CSB1511 + [FINISH]** - 1500 (W) x 450 (D) x 1100 (H)  
**GSB711 + [FINISH]** - 750 (W) x 450 (D) x 1100 (H)

**HINGE DOOR**  
**CS1511 + [FINISH]** - 1500 (W) x 450 (D) x 1100 (H)  
**GS711 + [FINISH]** - 750 (W) x 450 (D) x 1100 (H)

Accommodates lever arch files / Available in CN Exclusive Laminates, Anthracite, Black, Stone Grey & White

**NOTE: Handles must be ordered seperately**

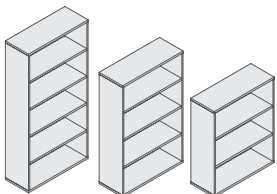

### GLOBAL BOOKCASES

**GS905 + [FINISH]** - 5 Tier: 900 (W) x 350 (D) x 1827 (H)  
**GS904 + [FINISH]** - 4 Tier: 900 (W) x 350 (D) x 1450 (H)  
**GS903 + [FINISH]** - 3 Tier: 900 (W) x 350 (D) x 1125 (H)

Accommodates lever arch files / Available in CN Exclusive Laminates, Anthracite, Black, Stone Grey & White



### GLOBAL TOP RETRIEVAL

**GS855 + [FINISH]**  
 1120 (W) x 590 (D) x 1340 (H)

Accommodates 12 x containers per drawer / 5 Drawers / Container filing only / Available in CN Exclusive Laminates, Anthracite, Black, Stone Grey & White

**\*Note: Includes Silver Handles**

## GLOBAL UTILITY UNITS

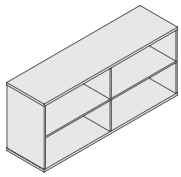

**DOUBLE UTILITY TOP FILER UNIT**  
**GS1602 + [FINISH]**  
 1600 (W) x 450 (D) x 706 (H)

Accommodates lever arch files / Use with double utility hinge door unit / Available in CN Exclusive Laminates, Anthracite, Black, Stone Grey & White

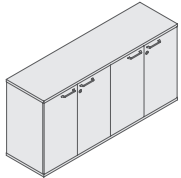

**DOUBLE UTILITY HINGE DOOR UNIT**  
**GS828 + [FINISH]**  
 1600 (W) x 450 (D) x 800 (H)

Accommodates lever arch files / Available in CN Exclusive Laminates, Anthracite, Black, Stone Grey & White

**NOTE: Handles must be ordered seperately**

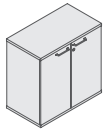

**SINGLE UTILITY HINGE DOOR UNIT**  
**GS827 + [FINISH]**  
 800 (W) x 450 (D) x 800 (H)

Accommodates lever arch files / Available in CN Exclusive Laminates, Anthracite, Black, Stone Grey & White

**NOTE: Handles must be ordered seperately**

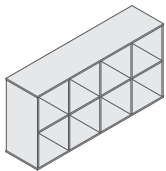

## GLOBAL PIGEON HOLE UNIT

**GS1682 + [FINISH]**  
 1600 (W) x 400 (D) x 821 (H)

8 Hole pigeon unit / Available in CN Exclusive Laminates, Anthracite, Black, Stone Grey & White

### LAMINATE FINISHES



ACACIA  
[AC]



DARK EUCALYPTUS  
[DE]



NATURAL WALNUT  
[NW]



TAORMINA ASH  
[TA]



TRUE OAK  
[TO]



ANTHRACITE  
[AN]



BLACK  
[BLK]



STONE GREY  
[SG]



WHITE  
[WH]





## GLOBAL TOP & BASE UNITS

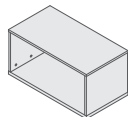

**TOP BOX**  
**GSB750 + [FINISH]**  
 400 (W) x 750 (D) x 371 (H)

Use with bench pedestal base unit / Available in CN Exclusive Laminates, Anthracite, Black, Stone Grey & White

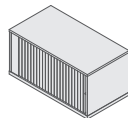

**ROLLER DOOR TOP BOX**  
**GSB751 + [FINISH]** - Silver roller door  
**GSB751 + [B] + [FINISH]** - Black roller door  
 400 (W) x 750 (D) x 380 (H)

Use with bench pedestal base unit / Black or silver roller door / Lockable / Available in CN Exclusive Laminates, Anthracite, Black, Stone Grey & White

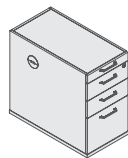

**BENCH PEDESTAL BASE UNIT**  
**GSB703 + [FINISH]**  
 400 (W) x 750 (D) x 700 (H)

1 x Pen & pencil drawer, 2 x standard drawers & 1 x deep filer / Available in CN Exclusive Laminates, Anthracite, Black, Stone Grey & White

**NOTE: Handles must be ordered seperately**

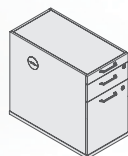

Left hand side shown

**BENCH PEDESTAL BASE UNIT**  
**GSB701 + [L/R] + [FINISH]**  
 400 (W) x 750 (D) x 700 (H)

1 x Pen & pencil drawer, 1 x standard drawer & 1 x hinge door / Available in CN Exclusive Laminates, Anthracite, Black, Stone Grey & White

**NOTE: Handles must be ordered seperately**

STANDARD HANDLES



BLACK  
 [VG128BLK]



SILVER  
 [VG128SI]



## BENCHWORK MOBILE PEDESTALS

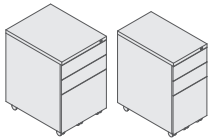

**STANDARD**  
**BFW706 + [BLK/SI/WH]**  
 400 (W) x 500 (D) x 600 (H)

**SLIM**  
**BFW706S + [BLK/SI/WH]**  
 300 (W) x 500 (D) x 600 (H)

300 (W) & 400 (W) Options / 1 x Floating pen & pencil tray, 2 x standard drawers & 1 x deep filer / Central locking / Available in Black [BLK], Silver [SI] or White [WH]

### FABRICS



VULCAN FABRICS [V]  
 Vulcan fabric colour to be specified on order



CUSTOMERS OWN MATERIAL [COM]

### OPTIONAL SEAT CUSHION

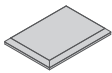

**BSC450 + [V/COM]** - Standard 400 (W)  
**BSC350 + [V/COM]** - Slim 300 (W)

Cushion in Vulcan fabric [V] or Customers Own Material [COM]

\*Fabric requirements : 0,6m seat cushion upholstery / 0,75m for 2 x cushions

## GLOBAL MUTE MINI MOBILE PEDESTAL

**GS400 + [B/W] + [FINISH] + [P]**  
 400 (W) x 400 (D) x 460 (H)

1 x Open compartment & 1 x deep drawer / Black or white finger grip handle / Drawer front clad in 100% Recyclable Polyester available in anthracite, black, cloud blue, leaf green, marble, lime, sage green, serenity blue or slate grey / Available in CN Exclusive Laminates, Anthracite, Black, Stone Grey & White

\*Polyester colour to be specified on order



### 100% POLYESTER COLOURS



ANTHRACITE [AN]

BLACK [BLK]

CLOUD BLUE [BL]

LEAF GREEN [GRN]

MARBLE [MR]

LIME [LM]

SAGE GREEN [SG]

SERENITY BLUE [SBL]

SLATE GREY [GR]

100% Polyester is extremely durable and requires little attention to maintain. Light dusting on a regular basis will prevent dust build up. Most marks can be cleaned with a mild detergent solution, followed by rinsing and blotting.

## GLOBAL SLIM MOBILE PEDESTALS

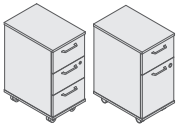

**GSS735 + [FINISH]** - 1 x Floating pen & pencil tray & 3 x standard drawers  
**GSS736 + [FINISH]** - 1 x Floating pen & pencil tray, 1 x standard drawer & 1 x deep filer  
 300 (W) x 450 (D) x 615 (H)

Central locking / Available in CN Exclusive Laminates, Anthracite, Black, Stone Grey & White

**NOTE: Handles must be ordered seperately**

### SLIM HANDLES



### LAMINATE FINISHES



NATURAL WALNUT  
[NW]



### STANDARD HANDLES



## GLOBAL MOBILE PEDESTALS

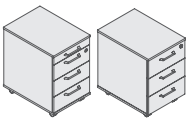

**GS705 + [FINISH]** - 1 x Pen & pencil tray & 3 x standard drawers  
**GS705F + [FINISH]** - 1 x Floating pen & pencil tray & 3 x standard drawers  
 400 (W) x 550 (D) x 590 (H)

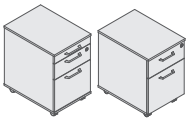

**GS706 + [FINISH]** - 1 x Pen & pencil tray, 1 x standard drawer & 1 x deep filer  
**GS706F + [FINISH]** - 1 x Floating pen & pencil tray, 1 x standard drawer & 1 x deep filer  
 400 (W) x 550 (D) x 590 (H)



**GS707 + [L/R] + [FINISH]** - 1 x Floating pen & pencil tray, 1 x standard drawer & 1 x hinge door  
 400 (W) x 550 (D) x 590 (H)

Central locking / Available in CN Exclusive Laminates, Anthracite, Black, Stone Grey & White

Left hand side shown

**NOTE: Handles must be ordered seperately**

## OPTIONAL SEAT CUSHION

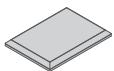

**GSC550 + [V/COM]** - Cushion in Vulcan fabric [V] or Customers Own Material [COM]

\*Fabric requirements : 0,6m seat cushion upholstery / 0,75m for 2 x cushions



STANDARD HANDLES



LAMINATE FINISHES



**GLOBAL SHARED PEDESTAL**

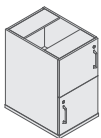

**GS713 + [FINISH]**  
400 (W) x 550 (D) x 700 (H)

2 x Hinge Doors / Central locking / Available in CN Exclusive Laminates, Anthracite, Black, Stone Grey & White

**NOTE: Handles must be ordered separately**

**GLOBAL ATTACHED PEDESTALS**

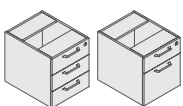

**GS709 + [FINISH]** - 1 x Floating pen & pencil tray & 3 x standard drawers  
**GS712 + [FINISH]** - 1 x Floating pen & pencil tray, 1 x standard drawer & 1 x deep filer  
395 (W) x 500 (D) x 450 (H)

Central locking / Available in CN Exclusive Laminates, Anthracite, Black, Stone Grey & White

**NOTE: Handles must be ordered separately**

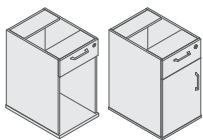

Left hand side shown

## GLOBAL DESK HEIGHT PEDESTALS

**GS700 + [FINISH]** - 1 x Floating pen & pencil tray, 1 x standard drawer & 1 x CPU compartment

**GS701L/R + [FINISH]** - 1 x Floating pen & pencil tray, 1 x standard drawer & 1 x hinge door  
400 (W) x 550 (D) x 700 (H)

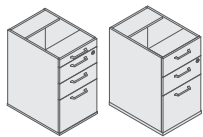

**GS703 + [FINISH]** - 1 x Pen & pencil drawer, 2 x standard drawers & 1 x deep filer

**GS703F + [FINISH]** - 1 x Floating pen & pencil tray, 2 x standard drawers & 1 x deep filer  
400 (W) x 550 (D) x 700 (H)

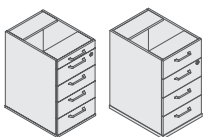

**GS704 + [FINISH]** - 1 x Pen & pencil drawer & 4 x standard drawers

**GS704F + [FINISH]** - 1 x Floating pen & pencil tray & 4 x standard drawers  
400 (W) x 550 (D) x 700 (H)

Central locking / Available in CN Exclusive Laminates, Anthracite, Black, Stone Grey & White

**NOTE:** Handles must be ordered seperately

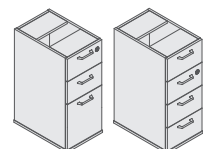

## GLOBAL SLIM DESK HEIGHT PEDESTALS

**GSS733 + [FINISH]** - 1 x Floating pen & pencil tray, 2 x standard drawers & 1 x deep filer

**GSS734 + [FINISH]** - 1 x Floating pen & pencil tray & 4 x standard drawers  
300 (W) x 450 (D) x 700 (H)

Central locking / Available in CN Exclusive Laminates, Anthracite, Black, Stone Grey & White

**NOTE:** Handles must be ordered seperately

SLIM HANDLES



BLACK  
[VG96BLK]



SILVER  
[VG96SI]

## UNDERSTANDING OUR STORAGE:

- A simple guide to illustrate the difference between Type A / Type B / LHS & RHS on our pedestal, credenza & pedenza storage options.

### PEDESTALS

#### DESK HEIGHT / MOBILE

##### LHS

Hinge door opens from right to left

##### RHS

Hinge door opens from left to right

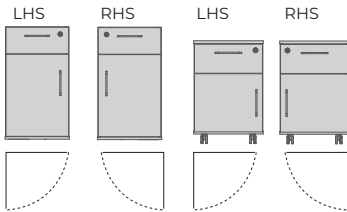

### CREDENZA

#### ROLLER DOOR

##### TYPE A

Roller door opens from left to right

##### TYPE B

Roller door opens from right to left

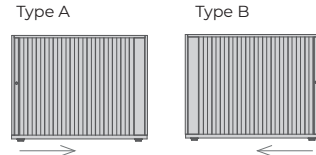

### PEDENZA

#### ROLLER DOOR

##### TYPE A

Roller door opens from left to right, set of drawers on left hand side

##### TYPE B

Roller door opens from right to left, set of drawers on right hand side

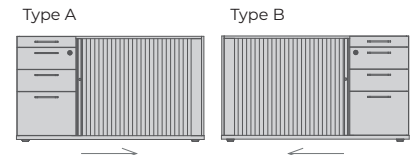

## GLOBAL CREDENZAS

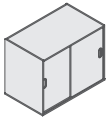

#### SLIDING DOOR GS811 + [FINISH]

900 (W) x 550 (D) x 700 (H)

Lockable / Includes timber shelf / Excludes extension top / Available in CN Exclusive Laminates, Anthracite, Black, Stone Grey & White

\*Note : Supplied with black plastic void handle

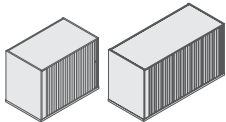

Roller door credenzas:  
Type B shown above

#### ROLLER DOOR - SILVER

##### GS810 + [A/B] + [FINISH]

900 (W) x 550 (D) x 700 (H)

##### GS812 + [A/B] + [FINISH]

1250 (W) x 550 (D) x 700 (H)

#### ROLLER DOOR - BLACK

##### GS810 + [A/B] + [B] + [FINISH]

900 (W) x 550 (D) x 700 (H)

##### GS812 + [A/B] + [B] + [FINISH]

1250 (W) x 550 (D) x 700 (H)

Type A or Type B / Black or silver roller door / Lockable / Systemised with optional universal metal storage inners / Excludes extension top / Available in CN Exclusive Laminates, Anthracite, Black, Stone Grey & White

#### LAMINATE FINISHES



ACACIA  
[AC]



DARK EUCALYPTUS  
[DE]



NATURAL WALNUT  
[NW]



TAORMINA ASH  
[TA]



TRUE OAK  
[TO]



ANTHRACITE  
[AN]



BLACK  
[BLK]



STONE GREY  
[SG]



WHITE  
[WH]

## GLOBAL PEDENZAS

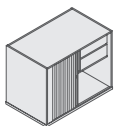

Type B shown

#### PERSONAL

##### GS800 + [A/B] + [FINISH] - Silver roller door

##### GS800 + [A/B] + [B] + [FINISH] - Black roller door

900 (W) x 550 (D) x 700 (H)

Type A or Type B / Black or silver roller door / 2 x Standard drawers attached pedestal / Lockable / Includes timber shelf / Excludes extension top / Available in CN Exclusive Laminates, Anthracite, Black, Stone Grey & White

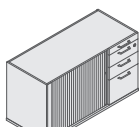

Type B shown

#### ROLLER DOOR

##### GS803 + [A/B] + [FINISH] - Silver roller door

##### GS803 + [A/B] + [B] + [FINISH] - Black roller door

1250 (W) x 550 (D) x 700 (H)

Type A or Type B / Black or silver roller door / 1 x Pen & pencil drawer, 2 x standard drawers & 1 x deep filer / Lockable / Systemised with optional universal metal storage inners / Excludes extension top / Available in CN Exclusive Laminates, Anthracite, Black, Stone Grey & White

NOTE: Handles must be ordered separately





FABRICS



VULCAN FABRICS

[V]

Vulcan fabric colour to be specified on order



CUSTOMERS OWN MATERIAL [COM]

STANDARD HANDLES



BLACK [VG128BLK]



SILVER [VG128SI]



Type A shown

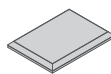

**GLOBAL MOBILE PEDENZA**

Type A or Type B / Black or silver roller door / Lockable / Includes timber shelf / 3 x Standard drawers / Available in CN Exclusive Laminates, Anthracite, Black, Stone Grey & White

**NOTE: Handles must be ordered seperately**

**GS815 + [A/B] + [FINISH]** - Silver roller door

**GS815 + [A/B] + [B] + [FINISH]** - Black roller door  
1150 (W) x 550 (D) x 567 (H)

**OPTIONAL SEAT CUSHION**

**GSC550 + [V/COM]** - Cushion in Vulcan fabric [V] or Customers Own Material [COM]

\*Fabric requirements : 0,6m seat cushion upholstery / 0,75m for 2 x cushions



## GLOBAL EXEC, OUR EXECUTIVE STORAGE SOLUTIONS WITH FINGER GRIP HANDLES HAS A MODERN APPEAL WITH FLEXIBILITY IN MIND.

### GLOBAL EXEC MOBILE PEDESTALS



**GSE705F + [B/W] + [FINISH]** - 400 (W) x 550 (D) x 590 (H)

1 x Floating pen & pencil tray & 3 x standard drawers / Central locking / Black or white finger grip handles / Available in CN Exclusive Laminates, Anthracite, Black, Stone Grey & White



**GSE706F + [B/W] + [FINISH]** - 400 (W) x 550 (D) x 590 (H)

1 x Floating pen & pencil tray, 1 x standard drawer & 1 x deep filer / Central locking / Black or white finger grip handles / Available in CN Exclusive Laminates, Anthracite, Black, Stone Grey & White

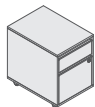

**GSE707 + [L/R] + [B/W] + [FINISH]** - 400 (W) x 550 (D) x 590 (H)

1 x Floating pen & pencil tray, 1 x standard drawer & 1 x hinge door / Central locking / Black or white finger grip handles / Available in CN Exclusive Laminates, Anthracite, Black, Stone Grey & White

Left hand side shown

### GLOBAL EXEC DESK HEIGHT PEDESTALS



**GSE701 + [L/R] + [B/W] + [FINISH]** - 400 (W) x 550 (D) x 700 (H)

1 x Floating pen & pencil tray, 1 x standard drawer & 1 x hinge door / Central locking / Black or white finger grip handles / Available in CN Exclusive Laminates, Anthracite, Black, Stone Grey & White

Left hand side shown



**GSE703F + [B/W] + [FINISH]** - 400 (W) x 550 (D) x 700 (H)

1 x Floating pen & pencil tray, 2 x standard drawers & 1 x deep filer / Central locking / Black or white finger grip handles / Available in CN Exclusive Laminates, Anthracite, Black, Stone Grey & White

### GLOBAL EXEC OPEN MOBILE SHELF UNIT

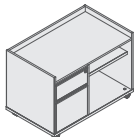

**GSE730 + [L/R] + [B/W] + [FINISH]**  
900 (W) x 550 (D) x 642 (H)

1 x Floating pen & pencil tray, 1 x standard drawer & 1 x hinge door / Central locking / Black or white finger grip handles / Available in CN Exclusive Laminates, Anthracite, Black, Stone Grey & White

Left hand side shown

### GLOBAL EXEC HINGE DOOR FILING CABINETS

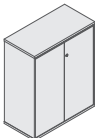

**GSE911 + [B/W] + [FINISH]**  
900 (W) x 450 (D) x 1100 (H)

2 x Hinge doors with black or white finger grip handles / Available in CN Exclusive Laminates, Anthracite, Black, Stone Grey & White

### GLOBAL EXEC RECYCLE UNIT



**GSE911R + [B/W] + [FINISH]**  
900 (W) x 450 (D) x 1100 (H)

**ADD01SI** - Silver Addis bin\*  
410 (W) x 330 (D) x 590 (H)  
\*2 x Addis bins required per cabinet

2 x Hinge doors with black or white finger grip handles / Available in CN Exclusive Laminates, Anthracite, Black, Stone Grey & White

\*Black finger grip handles will be paired with matt black perspex trim  
\*White finger grip handles will be paired with polar white perspex trim



**ADDIS SILVER BIN**  
[ADD01SI]



LAMINATE FINISHES

-  ACACIA [AC]
-  DARK EUCALYPTUS [DE]
-  NATURAL WALNUT [NW]
-  TAORMINA ASH [TA]
-  TRUE OAK [TO]
-  ANTHRACITE [AN]
-  BLACK [BLK]
-  STONE GREY [SG]
-  WHITE [WH]



**GLOBAL EXEC FLOWER BOX**

**GSE911F + [B/W] + [FINISH]**  
900 (W) x 450 (D) x 1100 (H)

**VFL858BLK** - Optional black waterproof liner\*  
858 (W) x 390 (D) x 130 (H)  
\*To be used with living plants

2 x Hinge doors with black or white finger grip handles / Available in CN Exclusive Laminates, Anthracite, Black, Stone Grey & White



**SILK PLANTS TO FIT FLOWER BOX**  
**GSILK8538**  
857 (W) x 388 (D) x 135 (H)

Dracena Bush planted in polystyrene base topped with moss / This option does not require the optional black waterproof liner / Polystyrene base fits directly into flower box

Images shown for display purposes only. Actual finishes may vary.





### GLOBAL EXEC WALL UNIT

**GSE1811 + [B/W] + [FINISH]**  
1800 (W) x 450 (D) x 1100 (H)

4 x Hinge doors with black or white finger grip handles / Includes timber shelves / Fixed open shelves / Available in CN Exclusive Laminates, Anthracite, Black, Stone Grey & White

### GLOBAL EXEC UTILITY HINGE DOOR UNITS

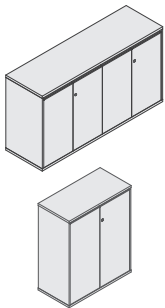

**GSE828 + [B/W] + [FINISH]** - Double  
1484 (W) x 450 (D) x 800 (H)

4 x Hinge doors with black or white finger grip handles / Available in CN Exclusive Laminates, Anthracite, Black, Stone Grey & White

**GSE827 + [B/W] + [FINISH]** - Single  
760 (W) x 450 (D) x 800 (H)

2 x Hinge doors with black or white finger grip handles / Available in CN Exclusive Laminates, Anthracite, Black, Stone Grey & White

### GLOBAL EXEC HINGE DOOR UNITS

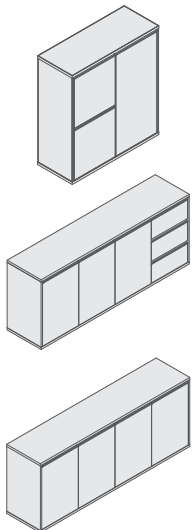

**GSE820 + [B/W] + [FINISH]**  
1000 (W) x 450 (D) x 1100 (H)

3 x Hinge doors with black or white finger grip handles / Includes timber shelves / Available in CN Exclusive Laminates, Anthracite, Black, Stone Grey & White

**GSE1986D + [B/W] + [FINISH]**  
1964 (W) x 450 (D) x 860 (H)

3 x Hinge doors, 3 x standard drawers with black or white finger grip handles / Includes timber shelves / Available in CN Exclusive Laminates, Anthracite, Black, Stone Grey & White

**GSE1986 + [B/W] + [FINISH]**  
1964 (W) x 450 (D) x 860 (H)

4 x Hinge doors with black or white finger grip handles / Includes timber shelves / Available in CN Exclusive Laminates, Anthracite, Black, Stone Grey & White

#### LAMINATE FINISHES



ACACIA  
[AC]



DARK EUCALYPTUS  
[DE]



NATURAL WALNUT  
[NW]



TAORMINA ASH  
[TA]



TRUE OAK  
[TO]



ANTHRACITE  
[AN]



BLACK  
[BLK]



STONE GREY  
[SG]



WHITE  
[WH]



**GLOBAL EVO**, OUR ELEVATED STORAGE RANGE WITH AN EXECUTIVE EDGE. A STYLISH AND CREATIVE STORAGE SOLUTION FOR THE MODERN WORKSPACE.



### GLOBAL EVO WALL UNIT

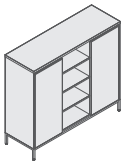

**GSV1312 + [FINISH]**  
1350 (W) x 450 (D) x 1200 (H)

2 x Hinge doors with black finger grip handles / Fixed open shelves / 19mm Black square tube frame / Available in CN Exclusive Laminates, Anthracite, Black, Stone Grey & White

### GLOBAL EVO

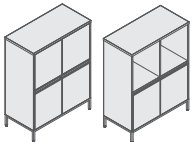

**TWO BY TWO**  
**GSV912H + [FINISH]** - 4 x Hinge doors  
**GSV912P + [FINISH]** - 2 x Hinge doors  
900 (W) x 450 (D) x 1200 (H)

Hinge doors with black finger grip handles / 19mm Black square tube frame / Available in CN Exclusive Laminates, Anthracite, Black, Stone Grey & White

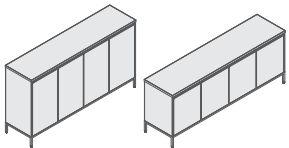

**FOUR BY ONE**  
**GSV1810H + [FINISH]** - High : 1000 (H)  
**GSV1872P + [FINISH]** - Low : 720 (H)  
1800 (W) x 450 (D)

Hinge doors with black finger grip handles / 19mm Black square tube frame / Available in CN Exclusive Laminates, Anthracite, Black, Stone Grey & White

### GLOBAL EVO

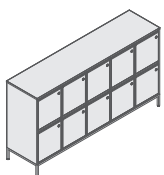

**LOCKER UNIT**  
**GSV1899L + [FINISH]**  
1800 (W) x 450 (D) x 992 (H)

10 Bay locker unit with 4-digit combination lock / Black finger grip handles / 19mm Black square tube frame / Available in CN Exclusive Laminates, Anthracite, Black, Stone Grey & White

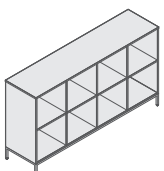

**PIGEON HOLE UNIT**  
**GSV1899P + [FINISH]**  
1800 (W) x 450 (D) x 992 (H)

8 Pigeon hole unit / 19mm Black square tube frame / Available in CN Exclusive Laminates, Anthracite, Black, Stone Grey & White

#### LAMINATE FINISHES



ACACIA  
[AC]



DARK EUCALYPTUS  
[DE]



NATURAL WALNUT  
[NW]



TAORMINA ASH  
[TA]



TRUE OAK  
[TO]



ANTHRACITE  
[AN]



BLACK  
[BLK]



STONE GREY  
[SG]



WHITE  
[WH]



## GLOBAL EVO

**3-TIER BOOKCASE**  
**GSV912B + [FINISH]**  
 900 (W) x 450 (D) x 1200 (H)

19mm Black square tube frame / Fixed shelves /  
 Available in CN Exclusive Laminates, Anthracite,  
 Black, Stone Grey & White



**HINGE DOOR FILING CABINET**  
**GSV912 + [FINISH]**  
 900 (W) x 450 (D) x 1200 (H)

2 x Hinge doors with black finger grip handles / Includes  
 2 x timber shelves / 19mm Black square tube frame /  
 Available in CN Exclusive Laminates, Anthracite, Black,  
 Stone Grey & White

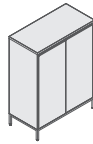



**STAC**, MODULAR UNITS FITTED WITH COLLETS & STUDS, ALLOWING YOU TO CREATE YOUR OWN COMPOSITION LIKE BUILDING BLOCKS, SIDE-BY-SIDE OR ON TOP OF EACH OTHER.

### STAC MODULAR STORAGE

Modular units fitted with collnets & studs, allowing you to create your own composition like building blocks, side by side or on top of each other / Available in CN Exclusive Laminates, Anthracite, Black, Stone Grey & White

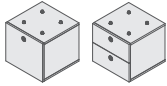

**DRAWER UNIT 400 (W)**  
**STS403 + [FINISH]** - 1 x Drawer  
**STD403 + [FINISH]** - 2 x Drawers  
 400 (W) x 400 (D) x 360 (H)

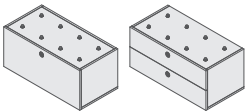

**DRAWER UNIT 800 (W)**  
**STS803 + [FINISH]** - 1 x Drawer  
**STD803 + [FINISH]** - 2 x Drawers  
 800 (W) x 400 (D) x 360 (H)

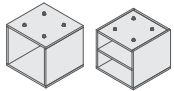

**OPEN UNIT 400 (W)**  
**STO403 + [FINISH]**  
**STOS403 + [FINISH]** - Including shelf  
 400 (W) x 400 (D) x 360 (H)

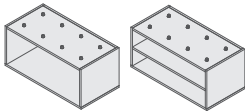

**OPEN UNIT 800 (W)**  
**STO803 + [FINISH]**  
**STOS803 + [FINISH]** - Including shelf  
 800 (W) x 400 (D) x 360 (H)

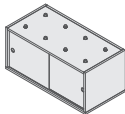

**OPEN UNIT 800 (W) - 2 x Perspex Sliding Doors**  
**STOSD803 + [B/W] + [FINISH]**  
 800 (W) x 400 (D) x 360 (H)  
 \*Perspex sliding doors available in Matt Black [BLK] or Polar White [WH] perspex

### STAC SEATS:

28mm Thick cushions in Vulcan fabric [V] or Customers Own Material [COM]

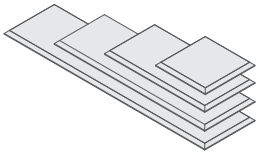

**STST404 + [V/COM]** - Fabric requirements : 0,6m  
 400 (W) x 400 (D)

**STST804 + [V/COM]** - Fabric requirements : 0,6m  
 800 (W) x 400 (D)

**STST1204 + [V/COM]** - Fabric requirements : 0,6m  
 1200 (W) x 400 (D)

**STST1604 + [V/COM]** - Fabric requirements : 1,7m  
 1600 (W) x 400 (D)

### LAMINATE FINISHES



ACACIA [AC]



DARK EUCALYPTUS [DE]



NATURAL WALNUT [NW]



TAORMINA ASH [TA]



TRUE OAK [TO]



ANTHRACITE [AN]



BLACK [BLK]



STONE GREY [SG]



WHITE [WH]

### FABRICS



**VULCAN FABRICS [V]**  
 Vulcan fabric colour to be specified on order



**CUSTOMERS OWN MATERIAL [COM]**







## STAC FEET

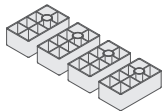

### STF001BLK

Black plastic clip-on feet / Set of 4

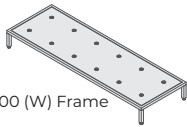

1200 (W) Frame

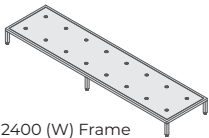

1600 - 2400 (W) Frame

## STAC FRAME

Black square tube frame with laminate board base / Available in CN Exclusive Laminates, Anthracite, Black, Stone Grey & White

- STF1200 + [FINISH] - 1200 (W) x 400 (D) x 128 (H)
- STF1600 + [FINISH] - 1600 (W) x 400 (D) x 128 (H)
- STF2000 + [FINISH] - 2000 (W) x 400 (D) x 128 (H)
- STF2400 + [FINISH] - 2400 (W) x 400 (D) x 128 (H)

## STAC FINISHING TOPS

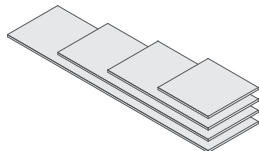

16mm Tops / Available in CN Exclusive Laminates, Anthracite, Black, Stone Grey & White

- STT404 + [FINISH] - 400 (W) x 400 (D) x 16mm
- STT804 + [FINISH] - 800 (W) x 400 (D) x 16mm
- STT1204 + [FINISH] - 1200 (W) x 400 (D) x 16mm
- STT1604 + [FINISH] - 1600 (W) x 400 (D) x 16mm



**DVIDE**, A STORAGE AND DISPLAY RANGE THAT IS FLAT-PACKED AND EASILY INSTALLED. OFFERING PRACTICAL STORAGE FOR OFFICE AND OPEN PLAN SPACES.

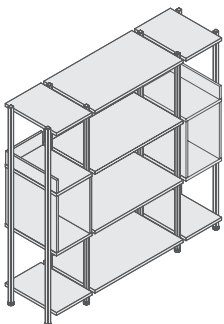

**DVIDE 1 WALL UNIT**

DV1 + [BLK/WH]  
1500 (W) x 450 (D) x 1500 (H)

**DVIDE FEATURES:**

- Square tube steel frame: 25mm
- Shelves 22mm, laminate
- Adjustable levelling feet
- Available in Black [BLK] & White [WH] laminates

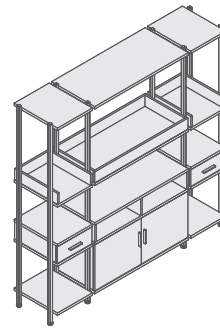

**DVIDE 2 WALL UNIT**

DV2 + [BLK/WH]  
1800 (W) x 450 (D) x 1800 (H)

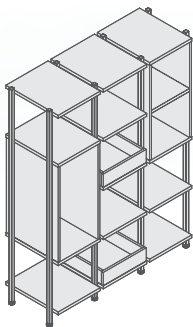

**DVIDE 3 WALL UNIT**

DV3 + [BLK/WH]  
1200 (W) x 450 (D) x 1600 (H)



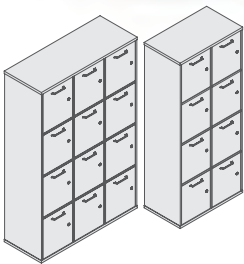

STANDARD HANDLES



BLACK  
[VG128BLK]

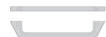

SILVER  
[VG128SI]

**GLOBAL LOCKERS**

8 or 12 Bay / Choice of 4-digit combination lock or camlock / Available in CN Exclusive Laminates, Anthracite, Black, Stone Grey & White

8 BAY

**GSC8 + [FINISH]** - Combination lock

**GSK8 + [FINISH]** - Camlock  
780 (W) x 450 (D) x 1800 (H)

12 BAY

**GSC12 + [FINISH]** - Combination lock

**GSK12 + [FINISH]** - Camlock  
1159 (W) x 450 (D) x 1800 (H)

**NOTE: Handles must be ordered seperately**

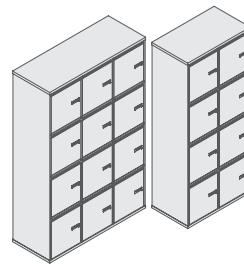

**GLOBAL EXEC LOCKERS**

8 or 12 Bay / Available with black or white finger grip handles / 4-digit combination lock / Available in CN Exclusive Laminates, Anthracite, Black, Stone Grey & White

8 BAY

**GSEC8 + [B/W] + [FINISH]**

780 (W) x 450 (D) x 1800 (H)

12 BAY

**GSEC12 + [B/W] + [FINISH]**

1159 (W) x 450 (D) x 1800 (H)

LAMINATE FINISHES



ACACIA  
[AC]



DARK EUCALYPTUS  
[DE]



NATURAL WALNUT  
[NW]



TAORMINA ASH  
[TA]



TRUE OAK  
[TO]



ANTHRACITE  
[AN]



BLACK  
[BLK]



STONE GREY  
[SG]



WHITE  
[WH]

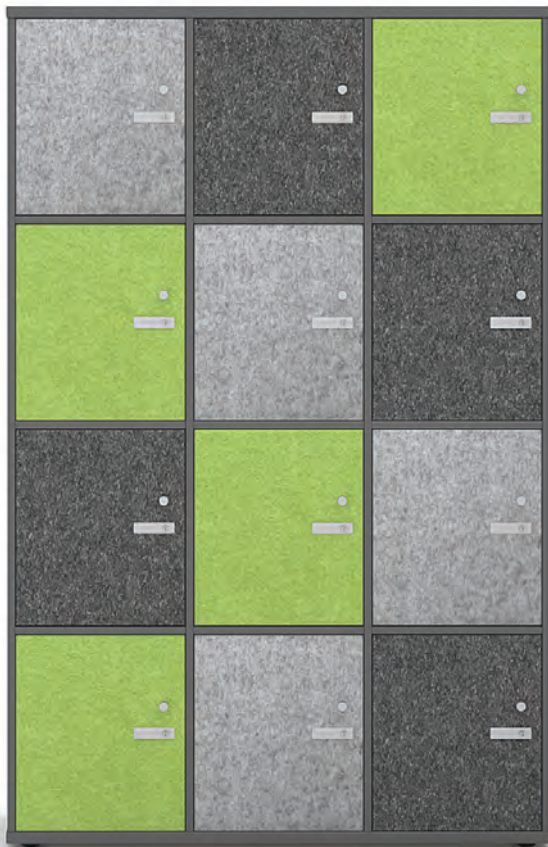

## GLOBAL MUTE LOCKERS

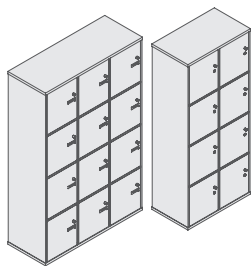

8 or 12 Bay / Silver knob handle / Choice of 4-digit combination lock or camlock / Available in CN Exclusive Laminates, Anthracite, Black, Stone Grey & White with door fronts clad in 100% recyclable polyester available in anthracite, black, cloud blue, leaf green, marble, lime, sage green, serenity blue or slate grey

### 8 BAY

**GSMC8 + [FINISH] + [P]** - Combination lock

**GSMK8 + [FINISH] + [P]** - Camlock

780 (W) x 450 (D) x 1800 (H)

### 12 BAY

**GSMC12 + [FINISH] + [P]** - Combination lock

**GSMK12 + [FINISH] + [P]** - Camlock

1159 (W) x 450 (D) x 1800 (H)

**\*Polyester colour to be specified on order**

### 100% POLYESTER COLOURS



ANTHRACITE  
[AN]



BLACK  
[BLK]



CLOUD BLUE  
[BL]



LEAF GREEN  
[GRN]

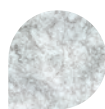

MARBLE  
[MR]



LIME  
[LM]



SAGE GREEN  
[SG]



SERENITY BLUE  
[SBL]



SLATE GREY  
[GR]

100% Polyester is extremely durable and requires little attention to maintain. Light dusting on a regular basis will prevent dust build up. Most marks can be cleaned with a mild detergent solution, followed by rinsing and blotting.



OUR **METAL STORAGE** UNITS DO MORE THAN JUST HOLD FILES, THEY PROVIDE EASY ACCESS TO MATERIALS, ARE ROBUST AND MAXIMISE REAL ESTATE - KEEPING YOU ORGANISED.

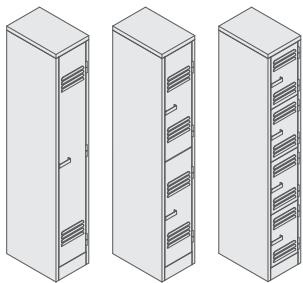

### **METAL STORAGE** LOCKERS

**LMT001 + [BLK/WH]** - Single Compartment

**LMT002 + [BLK/WH]** - 2 Compartments

**LMT004 + [BLK/WH]** - 4 Compartments

300 (W) x 450 (D) x 1800 (H)

Metal construction / Hasp & staple for padlock / Available in black or white



### **METAL FILING** DRAWERS

**MFC02 + [BLK/WH]** - 2 Drawers  
470 (W) x 630 (D) x 710 (H)

**MFC03 + [BLK/WH]** - 3 Drawers  
470 (W) x 630 (D) x 1015 (H)

**MFC04 + [BLK/WH]** - 4 Drawers  
470 (W) x 630 (D) x 1320 (H)

Metal construction / Hang rails & central locking / Available in black or white

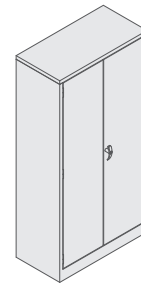

### **METAL STATIONERY** CABINET

**SMC900 + [BLK/WH]** - 2 Shelves  
900 (W) x 450 (D) x 900 (H)

**SMC1800 + [BLK/WH]** - 4 Shelves  
900 (W) x 450 (D) x 1800 (H)

Metal construction / Available in black or white



## METAL OPEN SHELVING UNIT

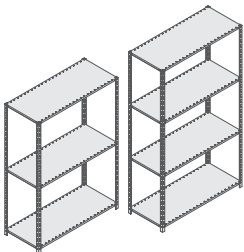

**OS3 + [457 / 381 / 305]** - 3 Shelf  
914 (W) x 1300 (H)

**OS4 + [457 / 381 / 305]** - 4 Shelf  
914 (W) x 1605 (H)

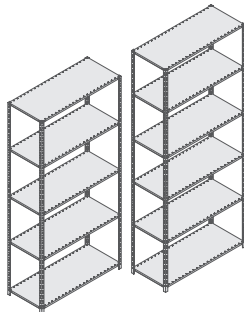

**OS5 + [457 / 381 / 305]** - 5 Shelf  
914 (W) x 1910 (H)

**OS6 + [457 / 381 / 305]** - 6 Shelf  
914 (W) x 2215 (H)

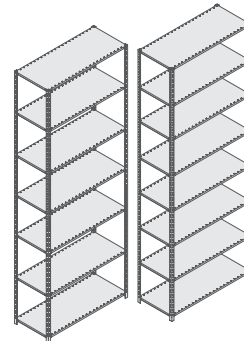

**OS7 + [457 / 381 / 305]** - 7 Shelf  
914 (W) x 2520 (H)

**OS8 + [457 / 381 / 305]** - 8 Shelf  
914 (W) x 2520 (H)

Metal construction in medium grey finish / Corner gussets included / Open back and sides / Available in the following depths : [457], [381] & [305]mm



## **TWIN CAB** CABINET



**TCM804 + [COLOUR]**  
**TCM804W + [COLOUR]** - Wrapped doors  
800 (W) x 400 (D) x 1000 (H)

Metal construction / 2 x Hinge doors including adjustable shelf / Wishbone or Latch handle options / Optional wrapped doors with graphic of choice / Available in Saxe Blue, Paris Green, Black or White

**\*Note :** Handle type to be specified on order



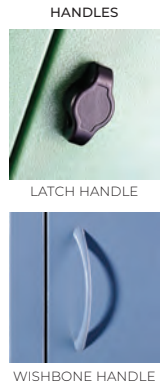

HANDLES

LATCH HANDLE

WISHBONE HANDLE



COLOURS



SAXE BLUE  
[BL]



PARIS GREEN  
[GRN]



BLACK  
[BLK]



WHITE  
[WH]



**LOLLI POP SINGLE DOOR LOCKER**

LPM001 + [COLOUR]  
LPM001W + [COLOUR] - Wrapped doors  
400 (W) x 450 (D) x 1800 (H)

Metal construction / Latch handle / Optional wrapped doors with graphic of choice / Available in Saxe Blue, Paris Green, Black or White

\*Note : Handle type to be specified on order

**ONE UP CABINET**

OUM654 + [COLOUR]  
OUM654W + [COLOUR] - Wrapped doors  
650 (W) x 400 (D) x 925 (H)

Metal construction / 2 x Hinge doors / Wishbone or Latch handle options / Optional wrapped doors with graphic of choice / Available in Saxe Blue, Paris Green, Black or White

\*Note : Handle type to be specified on order





## HIGH DENSITY CRADLES

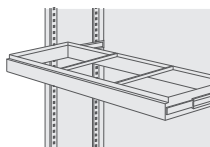

**A4 PULL-OUT CRADLES**  
**HDC400 + [FINISH]** - 400 (D)  
**HDC360 + [FINISH]** - 360 (D)

Suitable for 400 & 360 deep high density units / 3 Rows from back to front (files suspended from left to right) / It is recommended that no more than 5 cradles & 2 shelves be fitted per single bay

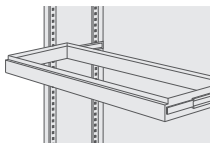

**FOOLSCAP PULL-OUT CRADLES**  
**HDC400F + [FINISH]** - 400 (D)  
**HDC360F + [FINISH]** - 360 (D)

Suitable for 400 & 360 deep high density units / It is recommended that no more than 5 cradles & 2 shelves be fitted per single bay

## HIGH DENSITY DRAWERS

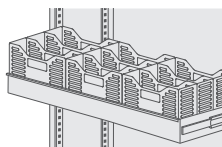

**PULL-OUT DRAWER**  
**HDD400 + [FINISH]** - 400 (D)

Suitable for 400 deep high density units / Accommodates 9 x A4 plastic containers / It is recommended that no more than 5 drawers & 2 shelves be fitted per single bay

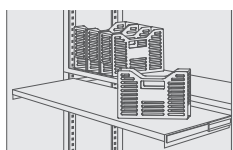

**PULL-OUT DRAWER**  
**HDD400 + [FINISH]** - 400 (D)

Suitable for 400 deep high density units / Accommodates 9 x A4 plastic containers / It is recommended that no more than 5 drawers & 2 shelves be fitted per single bay

## HIGH DENSITY DRAWERS

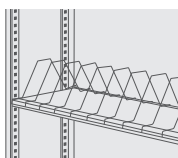

**WIRE RACK**  
**HDR400 + [FINISH]** - 400 (D)  
**HDR360 + [FINISH]** - 360 (D)

Suitable for 400 & 360 deep high density units / Supports lateral or lever arch files in an upright position / Use with standard shelf

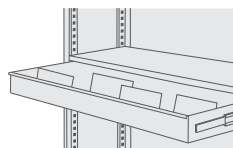

**PULL-OUT STATIONERY DRAWER**  
**HSD400 + [FINISH]** - 400 (D)

Can be used to store stationery, CD's etc / Lockable / Suitable for 400 deep high density units / The drawer is situated below a standard shelf

## HIGH DENSITY DRAWERS

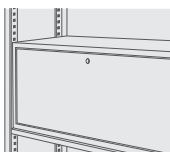

**LOCKABLE CABINET**  
**HDLC400 + [FINISH]** - 400 (D)  
**HDLC360 + [FINISH]** - 360 (D)

Independently lockable cabinet within a bay / Suitable for 400 & 360 deep high density units

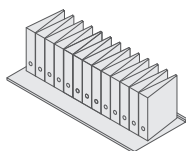

**STANDARD SHELF**  
**HDS400 + [FINISH]** - 400 (D)  
**HDS360 + [FINISH]** - 360 (D)

Suitable for 400 & 360 deep high density units / Accommodates 13 lever arch files or 10 x A4 containers filed laterally

### HIGH DENSITY COLOURS



### HIGH DENSITY FEATURES:

- Standard finish available in black, folkstone grey, storm grey & white
- Handle finish to be specified on order
- Optional laminate cladding available
- Internal fittings can be customised
- Costly floor space can be minimised

# HIGH DENSITY 400 (D) UNITS

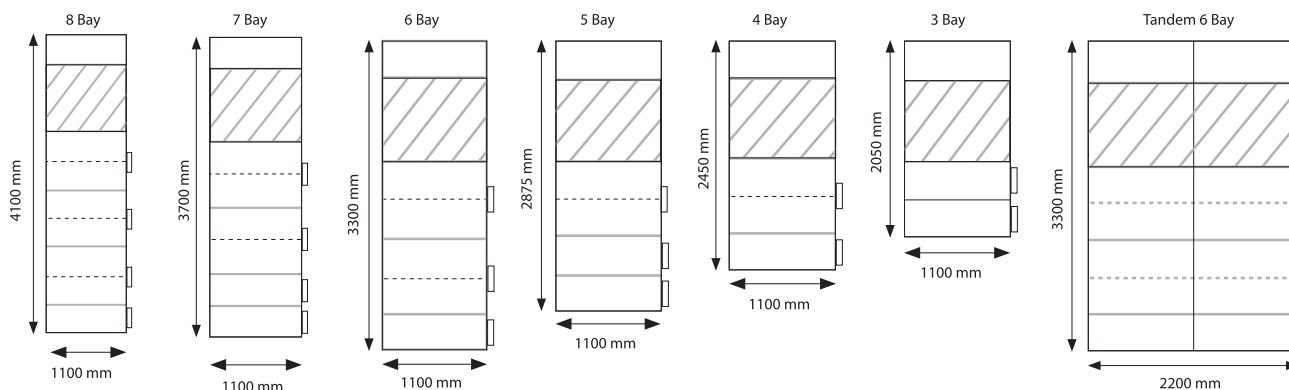

**HIGH DENSITY UNITS 400 (D)**  
 3 Bay solid back  
**HD03 + [FINISH]**  
 2050 (W) x 1100 (D) x 2350 (H)

**HIGH DENSITY UNITS 360 (D)**  
 3 Bay solid back  
**HD303 + [FINISH]**  
 1930 (W) x 1100 (D) x 2350 (H)

4 Bay solid back  
**HD04 + [FINISH]**  
 2450 (W) x 1100 (D) x 2350 (H)

4 Bay solid back  
**HD304 + [FINISH]**  
 2290 (W) x 1100 (D) x 2350 (H)

5 Bay solid back  
**HD05 + [FINISH]**  
 2875 (W) x 1100 (D) x 2350 (H)

5 Bay solid back  
**HD305 + [FINISH]**  
 2650 (W) x 1100 (D) x 2350 (H)

6 Bay solid back  
**HD06 + [FINISH]**  
 3300 (W) x 1100 (D) x 2350 (H)

6 Bay solid back  
**HD306 + [FINISH]**  
 3010 (W) x 1100 (D) x 2350 (H)

7 Bay solid back  
**HD07 + [FINISH]**  
 3700 (W) x 1100 (D) x 2350 (H)

7 Bay solid back  
**HD307 + [FINISH]**  
 3370 (W) x 1100 (D) x 2350 (H)

8 Bay solid back  
**HD08 + [FINISH]**  
 4100 (W) x 1100 (D) x 2350 (H)

8 Bay solid back  
**HD308 + [FINISH]**  
 3730 (W) x 1100 (D) x 2350 (H)

### HIGH DENSITY COLOURS

-  BLACK [BLK]
-  FOLKSTONE GREY [FG]
-  STORM GREY [SG]
-  WHITE [WH]

## HIGH DENSITY TUBE HANDLES

Available in black or aluminium / Colour to be specified on order



BLACK



ALUMINIUM



**CHAIN DRIVE**  
**HDCC01BLK**

Optional addition to assist with movement of bays / Best suited with tandem bays / Available in black



**KICKSTOOL**  
**KSO1LG**

Durable polypropylene material that won't scratch, dent or rust / 3 Wheels allowing complete mobility / Non-slip tread to top / Max. load 150kg / Available in light grey



**TOP RETRIEVAL**, MAXIMIZE YOUR FLOOR SPACE WITH OUR TOP RETRIEVAL UNITS, OFFERING YOU HIGH STORAGE CAPACITY WITH A SMALL FOOTPRINT.

**TOP RETRIEVAL FACTS:**

- Full metal internal frame
- Drawers have maisonite base plate
- Fitted with 103% extension runners
- 90kg's Capacity per drawer
- Anti-tilt mechanism
- Central locking
- 1 x Top retrieval cabinet is equivalent to 5 x 4 drawer steel cabinets

LAMINATE FINISHES

- ACACIA [AC]
- DARK EUCALYPTUS [DE]
- NATURAL WALNUT [NW]
- TAORMINA ASH [TA]
- TRUE OAK [TO]
- ANTHRACITE [AN]
- BLACK [BLK]
- STONE GREY [SC]
- WHITE [WH]

**TOP RETRIEVAL CABINETS**

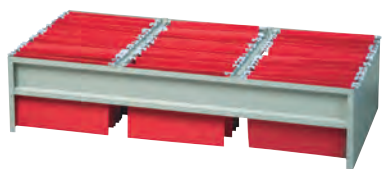

Image above shows the internal metal frame of a Top Retrieval Cabinet

- GS842 + [FINISH]** - 2 x Standard drawers  
1205 (W) x 595 (D) x 715 (H)
- GS843 + [FINISH]** - 3 x Standard drawers  
1205 (W) x 595 (D) x 969 (H)
- GS844 + [FINISH]** - 4 x Standard drawers  
1205 (W) x 595 (D) x 1217 (H)
- GS845 + [FINISH]** - 5 x Standard drawers  
1205 (W) x 595 (D) x 1465 (H)

Accommodates both containerised or hanging files\* / Available in CN Exclusive Laminates, Anthracite, Black, Stone Grey & White

\*Optional universal drop-in-cradle required for hanging files [UDC1200]



**UNIVERSAL DROP-IN CRADLE UDC1200**  
Adjustable metal dividers / Allows for 3 rows of A4 files or 2 rows of foolscap files / Folkstone grey

Images shown for display purposes only. Actual finishes may vary.

## STORAGE SOLUTIONS

**OFF-SITE STORAGE BOX**  
**CN2005**  
 433 (W) x 330 (D) x 255 (H)

**FOOLSCAP ARCHIVE BOX**  
**CN2003** - Standard Single Box  
 365 (W) x 115 (D) x 255 (H)

**CN2004** - Jumbo Single Box  
 365 (W) x 210 (D) x 255 (H)

**A4 ARCHIVE BOX**  
**CN2001** - Standard Single Box  
 330 (W) x 115 (D) x 255 (H)

**CN2002** - Jumbo Box  
 330 (W) x 210 (D) x 255 (H)

**BOARD CONTAINER**  
**CN5001** - A4 Container  
 320 (W) x 100 (D) x 220 (H)

**CN5003** - Foolscap Container  
 370 (W) x 100 (D) x 220 (H)



OFF-SITE STORAGE BOX

FOOLSCAP ARCHIVE BOX

A4 ARCHIVE BOX

A4 BOARD CONTAINER

FOOLSCAP BOARD CONTAINER



## SOFTWARE SOLUTIONS

**CN3002** - 25 per pack  
 120gsm Lightweight file / Holds 50 sheets of paper

**CN3004** - 25 per pack  
 190gsm Middle weight file / Holds 200 sheets of paper

**CN3008** - 25 per pack  
 250gsm Extra heavyweight file / Holds 350 sheets of paper

## A4 FILE DIVIDER

**A4 FILE DIVIDER**  
**CN4001**  
 25 per pack

80gsm File divider used to sub-divide the contents within a file



**SNAP CLIPS**  
**CN6001S**  
 10 per pack

Econo plastic snap clip / Used within a file to secure documents / Double-sided fixing tape included

## TOP RETRIEVAL FILING LABELS

### CN3015

Numeric labels mixed colour pack (14 Sheets per pack - 560 Labels)  
Label size: 30 (W) x 10mm (H)

### CNL5515

Alpha labels mixed colour pack (14 Sheets per pack - 336 labels)  
Label size: 55 (W) x 10mm (H)

### CN3010 + [COLOUR]

Numeric labels single colour pack (5 Sheets per pack - 200 Labels)  
Label size: 30 (W) x 10mm (H)

### CN5510 + [COLOUR]

Alpha labels single colour pack (6 Sheets per pack - 144 Labels)  
Label size: 55 (W) x 10mm (H)

#### AVAILABLE COLOURS

 WHITE [WH]	 DARK PINK [DPNK]
 DARK ORANGE [DOR]	 DARK GREEN [DGRN]
 LIGHT PINK [LPNK]	 LIGHT ORANGE [LORG]
 LIGHT GREEN [LGN]	 DARK YELLOW [DYL]
 DARK BLUE [DBL]	 DARK PURPLE [DPL]
 LIGHT YELLOW [LYL]	 LIGHT BLUE [LBL]
 LIGHT PURPLE [LPL]	 RED [RD]

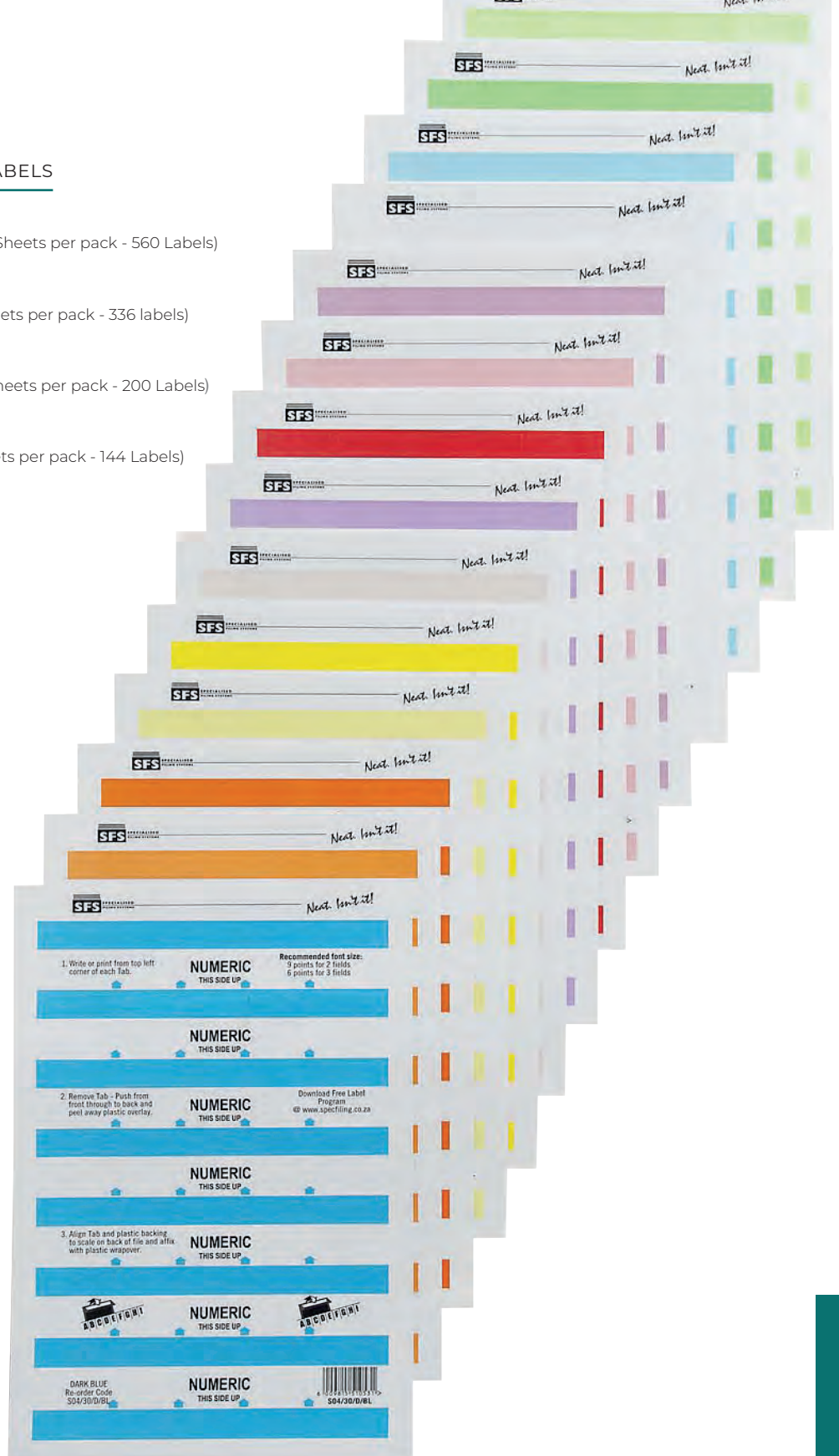

## A4 PLASTIC CONTAINER

### CN5005GGR

325 (W) x 100 (D) x 220 (H)

Clipping system which does not disassemble / Virgin grade ABS material / Available in graphite grey







# SCREENS



**GLOBAL SIDE STITCH**, OUR MOST COST EFFECTIVE SCREEN WITH SIMPLE CLEAN LINES AND CONCEALED BRACKETS.

**GLOBAL SIDE STITCH 365 (H) DESK BASED**

26mm Thick full fabric screen / Includes desk mounting brackets / Available in Vulcan fabric [V] or [COM]

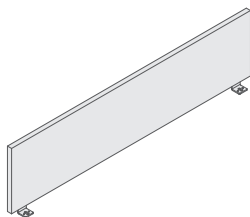

**GLSS650 + [V/COM]**  
650 (W) Fabric requirements : 0,9m

**GLSS1300 + [V/COM]**  
1300 (W) Fabric requirements : 1,5m

**GLSS1500 + [V/COM]**  
1500 (W) Fabric requirements : 1,7m

**GLSS1700 + [V/COM]**  
1700 (W) Fabric requirements : 1,9m

FABRICS



VULCAN FABRICS  
[V]  
Vulcan fabric colour to be specified on order



CUSTOMERS OWN MATERIAL  
[COM]



**GLOBAL PERSPEX**, A FRAMELESS PERSPEX SCREEN SUPPORTED WITH ATTRACTIVE ALUMINIUM BRACKETS.

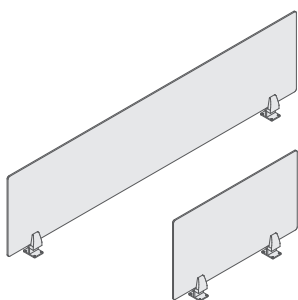

### **GLOBAL PERSPEX** SCREENS

**CENTRE SCREEN**  
**GLS1300 + [BLK/WH]** - 1300 (L) x 315 (H)  
**GLS1500 + [BLK/WH]** - 1500 (L) x 315 (H)  
**GLS1700 + [BLK/WH]** - 1700 (L) x 315 (H)

**RETURN SCREEN**  
**GLS650 + [BLK/WH]** - 650 (L) x 315 (H)

5mm Thick perspex screen / Excludes Global desk mounting brackets / Available in Matt Black [BLK] or Polar White [WH]



### **GLOBAL** DESK MOUNTING BRACKETS

**SINGLE DESK MOUNTING BRACKETS**  
**SBS01 + [AL/BLK]**

**DUAL DESK MOUNTING BRACKETS**  
**SBD02 + [AL/BLK]**

Set of two brackets / Suitable for 16 - 25mm tops / Available in Anodised Aluminium [AL] or Black [BLK]



**SIMPLE**, A FULL FABRIC SCREEN WITH ROUNDED CORNERS AND PVC EDGING, THAT CAN BE COVERED IN FABRIC AND TWO-TONED FOR A PLAYFUL LOOK.

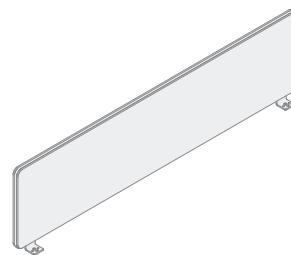

**SIMPLE SCREEN 370 (H) DESK BASED**

26mm Thick full fabric screen / PVC edge available in Vulcan fabric [V] or [COM] or black or silver edging

FABRICS



VULCAN FABRICS  
[V]  
Vulcan fabric colour to be  
specified on order



CUSTOMERS OWN MATERIAL  
[COM]



**SIMPLE SCREEN FABRIC COVERED PVC EDGE:**

SPF650 + [V/COM] - 650 (W) Fabric requirements : 0,9m  
 SPF1300 + [V/COM] - 1300 (W) Fabric requirements : 1,5m  
 SPF1500 + [V/COM] - 1500 (W) Fabric requirements : 1,7m  
 SPF1700 + [V/COM] - 1700 (W) Fabric requirements : 1,9m

26mm Thick full fabric screen / PVC edge available in Vulcan fabric [V] or [COM]



**SIMPLE SCREEN BLACK PVC EDGE:**

SPB650 + [V/COM] - 650 (W) Fabric requirements : 0,9m  
 SPB1300 + [V/COM] - 1300 (W) Fabric requirements : 1,5m  
 SPB1500 + [V/COM] - 1500 (W) Fabric requirements : 1,7m  
 SPB1700 + [V/COM] - 1700 (W) Fabric requirements : 1,9m

26mm Thick full fabric screen / PVC edge available in Black [B]



**SIMPLE SCREEN SILVER PVC EDGE:**

SPS650 + [V/COM] - 650 (W) Fabric requirements : 0,9m  
 SPS1300 + [V/COM] - 1300 (W) Fabric requirements : 1,5m  
 SPS1500 + [V/COM] - 1500 (W) Fabric requirements : 1,7m  
 SPS1700 + [V/COM] - 1700 (W) Fabric requirements : 1,9m

26mm Thick full fabric screen / PVC edge available in Silver [S]

\*[COM] Fabric requirement is based on plain fabric - 1,4m (W). For patterned fabric, add 20% to fabric requirement.

Images shown for display purposes only. Actual finishes may vary.

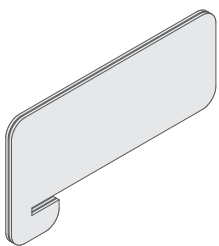

### GLOBAL MUTE COCOON

**GCS750 + [COLOUR]** - 750 (L) x 400 (H)

21mm Thick / 2 x 9mm 100% Polyester panels with 3mm MDF support panel to middle / Easily positioned / No brackets required / Available in anthracite, black, cloud blue, leaf green, marble, lime, sage green, serenity blue or slate grey

\*Fits on 25mm thick worktops only

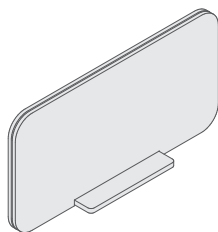

### GLOBAL MUTE BLINKER

**GBS600 + [COLOUR]** - 600 (L) x 300 (H)

21mm Thick / 2 x 9mm 100% Polyester panels with 3mm MDF support panel to middle / Free standing on black solid core base / No brackets required / Available in anthracite, black, cloud blue, leaf green, marble, lime, sage green, serenity blue or slate grey

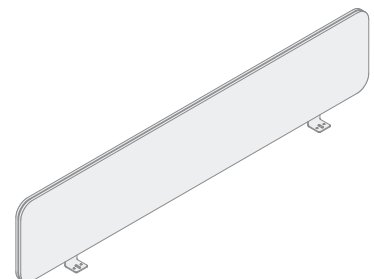

### GLOBAL MUTE DESK BASED

**300H**  
**GMS1300 + [COLOUR]** - 1300 (L) x 300 (H)  
**GMS1500\*+ [COLOUR]** - 1500 (L) x 300 (H)  
**GMS1700 + [COLOUR]** - 1700 (L) x 300 (H)

**400H**  
**GMS1340 + [COLOUR]** - 1300 (L) x 400 (H)  
**GMS1540\*+ [COLOUR]** - 1500 (L) x 400 (H)  
**GMS1740 + [COLOUR]** - 1700 (L) x 400 (H)

21mm Thick / 2 x 9mm 100% Polyester panels with 3mm MDF support panel to middle / Includes desk mounting brackets / Available in anthracite, black, cloud blue, leaf green, marble, lime, sage green, serenity blue or slate grey

\*GMS1500 / GMS1540 Screens can double up as a side screen on all Cecil Nurse dual desks.



**GLOBAL MUTE**, THESE FRAMELESS, PINNABLE SCREENS ARE LIGHT WEIGHT, COLOURFUL AND VERSATILE. THEY FIT ALL OUR SYSTEMS DESKING RANGES. MANUFACTURED FROM 100% RECYCLABLE POLYESTER, ARE EXTREMELY DURABLE AND EASY TO MAINTAIN.

**SCREEN CHARACTERISTICS:**

- Made from 100% recycled polyester
- Sound absorbing
- Water & impact resistant
- Non-toxic, no odour and low VOC emissions
- Fire retardant
- Pinnable surface
- Bacteria and fungi resistant
- Recyclable

100% POLYESTER COLOURS

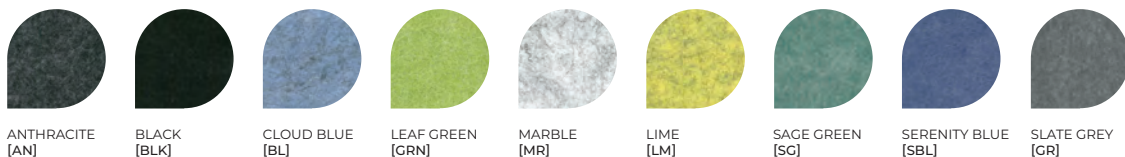

100% Polyester is extremely durable and requires little attention to maintain. Light dusting on a regular basis will prevent dust build up. Most marks can be cleaned with a mild detergent solution, followed by rinsing and blotting.



**SL22**, SLEEK ALUMINIUM PROFILE SCREENING SYSTEM WITH A NEAT MODERN DESIGN THAT WILL COMPLIMENT ANY OFFICE ENVIRONMENT WITH ITS MODULARITY POST SYSTEM, ELIMINATING SCREEN CREEP.



**SL22 360 (H) DESK BASED**

**FULL FABRIC**

**SLD6036 + [V/COM]**

600 (W) Fabric requirements : 0,9m

**SLD7036 + [V/COM]**

700 (W) Fabric requirements : 0,9m

**SLD7536 + [V/COM]**

750 (W) Fabric requirements : 0,9m

**SLD8036 + [V/COM]**

800 (W) Fabric requirements : 0,9m

**SLD1036 + [V/COM]**

1000 (W) Fabric requirements : 0,9m

**SLD1236 + [V/COM]**

1200 (W) Fabric requirements : 0,9m

**SLD12536 + [V/COM]**

1250 (W) Fabric requirements : 0,9m

**SLD1436 + [V/COM]**

1400 (W) Fabric requirements : 1,5m

**SLD1536 + [V/COM]**

1500 (W) Fabric requirements : 1,7m

**SLD1636 + [V/COM]**

1600 (W) Fabric requirements : 1,7m

**SLD1836 + [V/COM]**

1800 (W) Fabric requirements : 1,9m

22mm Thick fabric screen with aluminium profile / Available in Vulcan fabric [V] or [COM]

\*[COM] Fabric requirement is based on plain fabric - 1,4m (W). For patterned fabric, add 20% to fabric requirement.



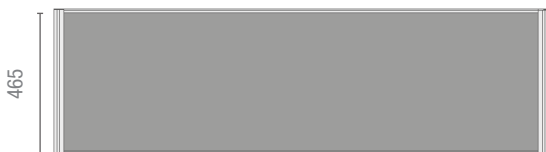

**SL22 465 (H) DESK BASED**

**FULL FABRIC**

- SLD6046 + [V/COM]**  
600 (W) Fabric requirements : 1,0m
- SLD7046 + [V/COM]**  
700 (W) Fabric requirements : 1,0m
- SLD7546 + [V/COM]**  
750 (W) Fabric requirements : 1,0m
- SLD8046 + [V/COM]**  
800 (W) Fabric requirements : 1,0m

- SLD1046 + [V/COM]**  
1000 (W) Fabric requirements : 1,0m
- SLD1246 + [V/COM]**  
1200 (W) Fabric requirements : 1,0m
- SLD12546 + [V/COM]**  
1250 (W) Fabric requirements : 1,0m
- SLD1446 + [V/COM]**  
1400 (W) Fabric requirements : 1,5m

- SLD1546 + [V/COM]**  
1500 (W) Fabric requirements : 1,7m
- SLD1646 + [V/COM]**  
1600 (W) Fabric requirements : 1,7m
- SLD1846 + [V/COM]**  
1800 (W) Fabric requirements : 1,9m

22mm Thick fabric screen with aluminium profile / Available in Vulcan fabric [V] or [COM]

\*[COM] Fabric requirement is based on plain fabric - 1,4m (W). For patterned fabric, add 20% to fabric requirement.

**FABRICS**



**VULCAN FABRICS**  
[V]  
Vulcan fabric colour to be specified on order



**CUSTOMERS OWN MATERIAL**  
[COM]

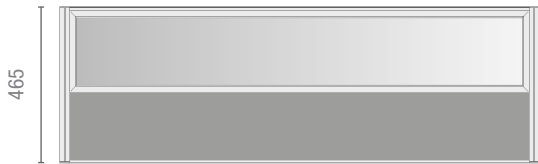

**SL22 465 (H) DESK BASED**

**TOP GLASS / FABRIC**

**SLD6046G + [V/COM]**  
600 (W) Fabric requirements : 0,8m  
**SLD7046G + [V/COM]**  
700 (W) Fabric requirements : 0,8m  
**SLD7546G + [V/COM]**  
750 (W) Fabric requirements : 0,9m  
**SLD8046G + [V/COM]**  
800 (W) Fabric requirements : 0,9m

**SLD1046G + [V/COM]**  
1000 (W) Fabric requirements : 1,1m  
**SLD1246G + [V/COM]**  
1200 (W) Fabric requirements : 1,2m  
**SLD12546G + [V/COM]**  
1250 (W) Fabric requirements : 1,3m  
**SLD1446G + [V/COM]**  
1400 (W) Fabric requirements : 1,5m

**SLD1546G + [V/COM]**  
1500 (W) Fabric requirements : 1,7m  
**SLD1646G + [V/COM]**  
1600 (W) Fabric requirements : 1,7m  
**SLD1846G + [V/COM]**  
1800 (W) Fabric requirements : 1,9m

22mm Thick fabric screen with aluminium profile / Available in Vulcan fabric [V] or [COM]

\*[COM] Fabric requirement is based on plain fabric - 1,4m (W). For patterned fabric, add 20% to fabric requirement.

FABRICS



**VULCAN FABRICS [V]**  
Vulcan fabric colour to be specified on order



**CUSTOMERS OWN MATERIAL [COM]**

**MODULARITY POSTS:**



**MODULARITY POST  
3-WAY 90° CONNEXION**



**MODULARITY POST  
2-WAY 90° CONNECTION**



**CONCEALED SCREEN POST  
2-WAY 180° CONNECTION**

**SL22 FLOOR BASED SCREENS:**



**SL22 FLOOR BASED SCREENS**

**STABILISING FEET OPTIONS**

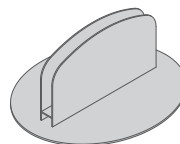

**SL22 CLAMP FOOT  
SLCLAMP**

Available in silver painted finish

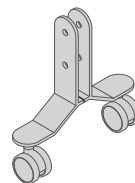

**SL22 MOBILE FOOT  
SLMOBILE**

Available in silver painted finish with black lockable castors

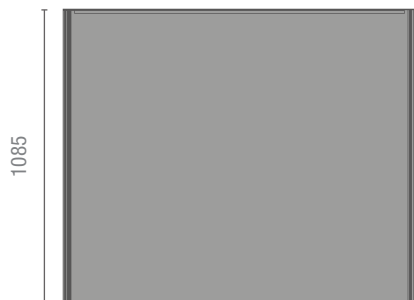

### **SL22 1085 (H) FLOOR BASED**

#### **FULL FABRIC**

**SLF6011 + [V/COM]**  
600 (W) Fabric requirements : 1,2m  
**SLF7011 + [V/COM]**  
700 (W) Fabric requirements : 1,5m  
**SLF7511 + [V/COM]**  
750 (W) Fabric requirements : 1,6m  
**SLF8011 + [V/COM]**  
800 (W) Fabric requirements : 1,7m  
**SLF1011 + [V/COM]**  
1000 (W) Fabric requirements : 2,1m  
**SLF1211 + [V/COM]**  
1200 (W) Fabric requirements : 2,5m

**SLF12511 + [V/COM]**  
1250 (W) Fabric requirements : 2,6m  
**SLF1411 + [V/COM]**  
1400 (W) Fabric requirements : 2,9m  
**SLF1511 + [V/COM]**  
1500 (W) Fabric requirements : 3,3m  
**SLF1611 + [V/COM]**  
1600 (W) Fabric requirements : 3,3m  
**SLF1811 + [V/COM]**  
1800 (W) Fabric requirements : 3,7m

22mm Thick fabric screen with aluminium profile / Available in Vulcan fabric [V] or [COM]

\*[COM] Fabric requirement is based on plain fabric - 1,4m (W). For patterned fabric, add 20% to fabric requirement.

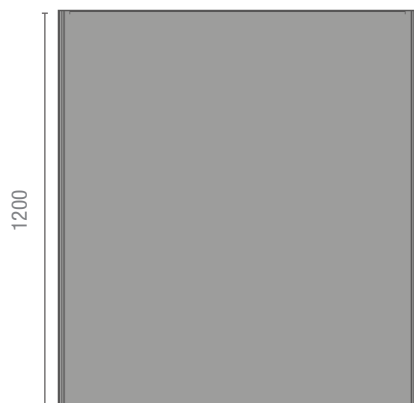

### **SL22 1200 (H) FLOOR BASED**

#### **FULL FABRIC**

**SLF6012 + [V/COM]**  
600 (W) Fabric requirements : 1,2m  
**SLF7012 + [V/COM]**  
700 (W) Fabric requirements : 1,5m  
**SLF7512 + [V/COM]**  
750 (W) Fabric requirements : 1,6m  
**SLF8012 + [V/COM]**  
800 (W) Fabric requirements : 1,7m  
**SLF1012 + [V/COM]**  
1000 (W) Fabric requirements : 2,1m  
**SLF1212 + [V/COM]**  
1200 (W) Fabric requirements : 2,5m

**SLF12512 + [V/COM]**  
1250 (W) Fabric requirements : 2,6m  
**SLF1412 + [V/COM]**  
1400 (W) Fabric requirements : 2,9m  
**SLF1512 + [V/COM]**  
1500 (W) Fabric requirements : 3,3m  
**SLF1612 + [V/COM]**  
1600 (W) Fabric requirements : 3,3m  
**SLF1812 + [V/COM]**  
1800 (W) Fabric requirements : 3,7m

22mm Thick fabric screen with aluminium profile / Available in Vulcan fabric [V] or [COM]

\*[COM] Fabric requirement is based on plain fabric - 1,4m (W). For patterned fabric, add 20% to fabric requirement.

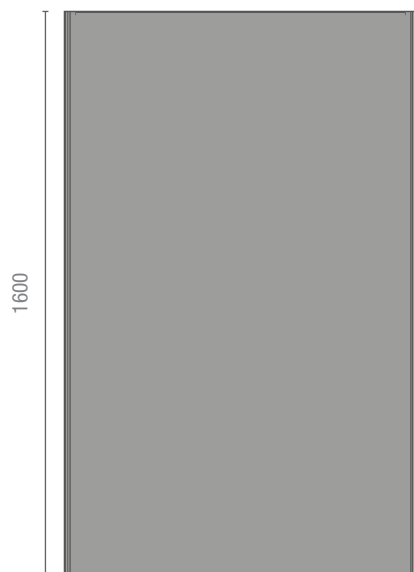

### **SL22 1600 (H) FLOOR BASED**

#### **FULL FABRIC**

**SLF6016 + [V/COM]**  
600 (W) Fabric requirements : 1,7m  
**SLF7016 + [V/COM]**  
700 (W) Fabric requirements : 3,3m  
**SLF7516 + [V/COM]**  
750 (W) Fabric requirements : 3,3m  
**SLF8016 + [V/COM]**  
800 (W) Fabric requirements : 3,3m

**SLF1016 + [V/COM]**  
1000 (W) Fabric requirements : 3,3m  
**SLF1216 + [V/COM]**  
1200 (W) Fabric requirements : 3,3m  
**SLF12516 + [V/COM]**  
1250 (W) Fabric requirements : 3,3m

22mm Thick fabric screen with aluminium profile / Available in Vulcan fabric [V] or [COM]

\*[COM] Fabric requirement is based on plain fabric - 1,4m (W). For patterned fabric, add 20% to fabric requirement.



**SLIMLINE**, AN ALUMINIUM PROFILE SCREENING SYSTEM WITH A STRONG, STURDY CONSTRUCTION AND INTERLOCKING PROFILE DESIGN ALLOWING FOR SIMPLE INSTALLATIONS.

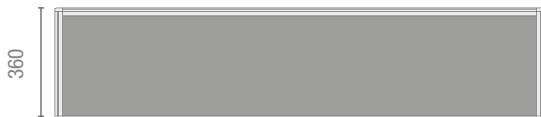

### SLIMLINE 360 (H) DESK BASED

#### FULL FABRIC

**SD6036 + [V/COM]**  
600 (W) Fabric requirements : 0,7m  
**SD7036 + [V/COM]**  
700 (W) Fabric requirements : 0,8m  
**SD7536 + [V/COM]**  
750 (W) Fabric requirements : 0,9m  
**SD8036 + [V/COM]**  
800 (W) Fabric requirements : 0,9m

**SD1036 + [V/COM]**  
1000 (W) Fabric requirements :1,1m  
**SD1236 + [V/COM]**  
1200 (W) Fabric requirements : 1,1m  
**SD12536 + [V/COM]**  
1250 (W) Fabric requirements : 1,1m  
**SD1436 + [V/COM]**  
1400 (W) Fabric requirements : 1,5m

**SD1536 + [V/COM]**  
1500 (W) Fabric requirements : 1,7m  
**SD1636 + [V/COM]**  
1600 (W) Fabric requirements : 1,7m  
**SD1836 + [V/COM]**  
1800 (W) Fabric requirements : 1,9m

#### FABRICS



VULCAN FABRICS  
[V]  
Vulcan fabric colour to be  
specified on order



CUSTOMERS OWN MATERIAL  
[COM]



### SLIMLINE 465 (H) DESK BASED

#### FULL FABRIC

**SD6046 + [V/COM]**  
600 (W) Fabric requirements : 0,7m  
**SD7046 + [V/COM]**  
700 (W) Fabric requirements : 0,8m  
**SD7546 + [V/COM]**  
750 (W) Fabric requirements : 0,9m  
**SD8046 + [V/COM]**  
800 (W) Fabric requirements : 0,9m

**SD1046 + [V/COM]**  
1000 (W) Fabric requirements :1,1m  
**SD1246 + [V/COM]**  
1200 (W) Fabric requirements : 1,1m  
**SD12546 + [V/COM]**  
1250 (W) Fabric requirements : 1,1m  
**SD1446 + [V/COM]**  
1400 (W) Fabric requirements : 1,5m

**SD1546 + [V/COM]**  
1500 (W) Fabric requirements : 1,7m  
**SD1646 + [V/COM]**  
1600 (W) Fabric requirements : 1,7m  
**SD1846 + [V/COM]**  
1800 (W) Fabric requirements : 1,9m

#### SLIMLINE BLACK

- For Slimline Screens with aluminium profile in black powder coated finish, add [B] to the suffix of the code before your fabric choice

32mm Thick fabric screen with aluminium profile / Available in Vulcan fabric [V] or [COM]  
\*[COM] Fabric requirement is based on plain fabric - 1,4m (W). For patterned fabric, add 20% to fabric requirement.

Images shown for display purposes only. Actual finishes may vary.

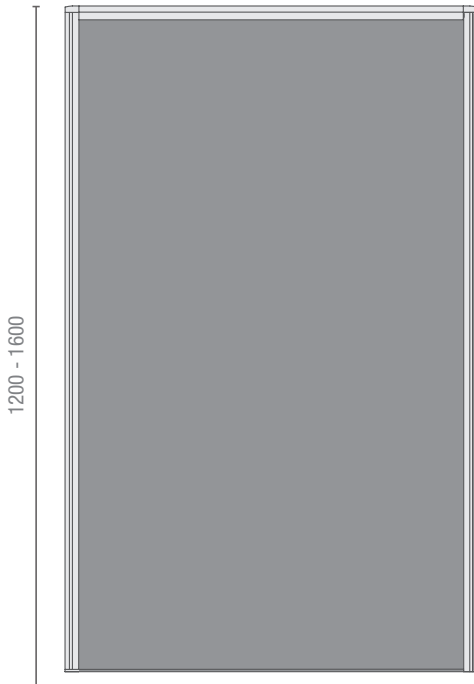

## SLIMLINE 1200 (H) FLOOR BASED

### FULL FABRIC

**SB6012 + [V/COM]**  
600 (W) Fabric requirements : 1,3m  
**SB7012 + [V/COM]**  
700 (W) Fabric requirements : 1,5m  
**SB7512 + [V/COM]**  
750 (W) Fabric requirements : 1,6m  
**SB8012 + [V/COM]**  
800 (W) Fabric requirements : 1,7m  
**SB1012 + [V/COM]**  
1000 (W) Fabric requirements : 2,1m  
**SB1212 + [V/COM]**  
1200 (W) Fabric requirements : 2,5m

**SB12512 + [V/COM]**  
1250 (W) Fabric requirements : 2,6m  
**SB1412 + [V/COM]**  
1400 (W) Fabric requirements : 2,9m  
**SB1512 + [V/COM]**  
1500 (W) Fabric requirements : 3,3m  
**SB1612 + [V/COM]**  
1600 (W) Fabric requirements : 3,3m  
**SB1812 + [V/COM]**  
1800 (W) Fabric requirements : 3,7m

## SLIMLINE 1600 (H) FLOOR BASED

### FULL FABRIC

**SB6016 + [V/COM]**  
600 (W) Fabric requirements : 1,3m  
**SB7016 + [V/COM]**  
700 (W) Fabric requirements : 1,5m  
**SB7516 + [V/COM]**  
750 (W) Fabric requirements : 1,6m  
**SB8016 + [V/COM]**  
800 (W) Fabric requirements : 1,7m

**SB1016 + [V/COM]**  
1000 (W) Fabric requirements : 2,1m  
**SB1216 + [V/COM]**  
1200 (W) Fabric requirements : 2,5m  
**SB12516 + [V/COM]**  
1250 (W) Fabric requirements : 2,6m

## SLIMLINE BLACK

- For Slimline Screens with aluminium profile in black powder coated finish, add **[B]** to the suffix of the code before your fabric choice

32mm Thick fabric screen with aluminium profile / Available in Vulcan fabric [V] or [COM]

\*[COM] Fabric requirement is based on plain fabric - 1,4m (W). For patterned fabric, add 20% to fabric requirement.

## SLIMLINE BOUNDARY SCREEN



## SLIMLINE BOUNDARY SCREEN ACCESSORIES

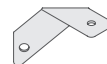

**TAGGING BRACKET**  
**SB3044** - Per single bracket

Allows for boundary screen to be tagged to desk top

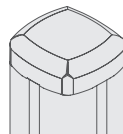

**BOUNDARY SCREEN POST**  
**SB3060** - Use for 1200 (H) screens  
**SB3063** - Use for 1600 (H) screens

Use when 90° angle is formed by boundary screens

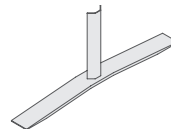

**STABILISING FOOT**  
**SB3000** - Per single bracket

Allows for stability of static boundary screens

### FABRICS



VULCAN FABRICS  
[V]

Vulcan fabric colour to be specified on order



CUSTOMERS OWN MATERIAL  
[COM]

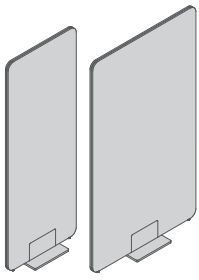

## MUTE BOUNDARY SCREEN

MBS6016 + [COLOUR] - 600 (W) x 1600 (H)

MBS9016 + [COLOUR] - 900 (W) x 1600 (H)

24mm Thick / 2 x 9mm 100% Polyester panels with 6mm MDF support panel to middle / Excludes screen clamp foot / Available in anthracite, black, cloud blue, leaf green, marble, lime, sage green, serenity blue or slate grey

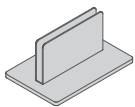

**MUTE BOUNDARY SCREEN CLAMP FOOT**  
Each / Black solid core base with U-Clamp

**MBSCLAMP**



### SCREEN CHARACTERISTICS

- Made from 100% polyester
- Sound absorbing
- Water & impact resistant
- Non-toxic, no odour and low VOC emissions
- Fire retardant
- Pinnable surface
- Bacteria and fungi resistant
- Recyclable

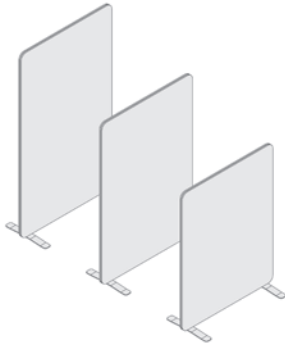

## MUTE MIRA BOUNDARY SCREEN

MMS9012 + [COLOUR] - 900 (W) x 1200 (H)

MMS9014 + [COLOUR] - 900 (W) x 1400 (H)

MMS9016 + [COLOUR] - 900 (W) x 1600 (H)

24mm Thick / 2 x 9mm 100% Polyester panels with 6mm MDF support panel to middle / Excludes Mira stabilising feet / Available in anthracite, black, cloud blue, leaf green, marble, lime, sage green, serenity blue or slate grey

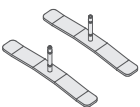

**MIRA BOUNDARY SCREEN STABILISING FEET**  
Set of two / Available in Black [BLK] & White [WH]

**MSB04 + [BLK/WH]**

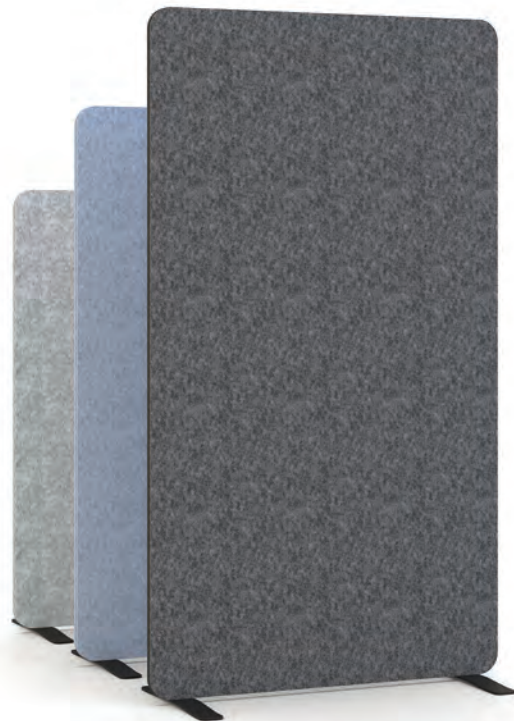

### 100% POLYESTER COLOURS

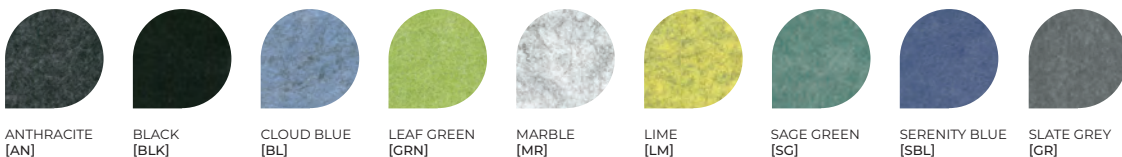

ANTHRACITE  
[AN]

BLACK  
[BLK]

CLOUD BLUE  
[BL]

LEAF GREEN  
[GRN]

MARBLE  
[MR]

LIME  
[LM]

SAGE GREEN  
[SG]

SERENITY BLUE  
[SBL]

SLATE GREY  
[GR]

100% Polyester is extremely durable and requires little attention to maintain. Light dusting on a regular basis will prevent dust build up. Most marks can be cleaned with a mild detergent solution, followed by rinsing and blotting.







# SEATING



## OF COURSE

### HIGH BACK CHAIR OF01BLK

Synchronised mechanism / Moulded foam seat & back /  
5-Star polished aluminium base with 65mm self-braking castors /  
Genuine black leather upholstery with Eco-leather outer back



Sirtland®

**MEETING CHAIR  
OF04BLK**

Fixed height with swivel & memory return function / 4-Star polished aluminum base on glides / Genuine black leather upholstery with Eco-leather outer back

Images shown for display purposes only. Actual finishes may vary.

100%  
EXCLUSIVE

**RISE**, CHAIR IS MODERN, SIMPLE AND ELEGANT WITH EXQUISITE STITCHING, THAT ENHANCES ITS SIMPLE LINES.



## RISE

HIGH BACK CHAIR  
RS01 + [FABRIC]

MEDIUM BACK CHAIR  
RS02 + [FABRIC]

DONATI Synchronised mechanism / Integrated seat, arm and backrest structure / 5-Star polished aluminium base with 60mm castors / Black or light brown genuine leather upholstery to front with PVC to back

### FABRICS

 BLACK LEATHER  
[BLK]

 LIGHT BROWN LEATHER  
[LBR]

The **RISE** chair meets the following international standard : **BIFMA & GREENGUARD GOLD**.

Images shown for display purposes only. Actual finishes may vary.



**ALEK**, EXPRESSES A HIGH LEVEL OF ELEGANCE AND STYLE, WITH A PERFECT BALANCE BETWEEN ARTISTIC AESTHETICS AND FUNCTIONAL APPLICATIONS.



## ALEK

HIGH BACK CHAIR  
ALK01BLK

DONATI Synchronised mechanism / Integrated seat and backrest structure / Fixed aluminium armrests / 5-Star polished aluminium base with 60mm castors / Black genuine leather upholstery to front with PVC to back

The ALEK chair meets the following international standards : BIFMA & GREENGUARD GOLD.



SitLand®

**LINE**, IS THE COLLECTION OF EXECUTIVE, MANAGERIAL AND MEETING CHAIRS. WITH ELEGANT CANTILEVERED ARMRESTS AND ULTRA-SLIM SEAT AND BACK WITH HORIZONTAL STITCHING.



**LINE**

**HIGH BACK CHAIR  
LN01BLK**

Tilting mechanism / Fixed aluminium arms with soft touch polyurethane top / 5-Star polished aluminium base with 65mm castors / Black genuine leather upholstery with Eco-leather outer back

**MEDIUM CHAIR  
LN02BLK**

Tilting mechanism / Fixed aluminium arms with soft touch polyurethane top / 5-Star polished aluminium base with 65mm castors / Black genuine leather upholstery with Eco-leather outer back

**MEETING CHAIR  
LN04BLK**

Swivel seat, fixed height / Fixed aluminium arms with back soft touch polyurethane top / 4-Star polished aluminium base / Black genuine leather upholstery with Eco-leather outer back

The **LINE** chairs meet the following international standard : **CATAS Certified**.

Images shown for display purposes only. Actual finished may vary.

100%  
EXCLUSIVE

**FRESH**, WITH ITS ERGONOMIC SEAT AND BACK PADDED WITH SHAPE-RETAINING FLEXIBLE POLYURETHANE, ENSURES MAXIMUM POSTURAL COMFORT FOR PROLONGED EVERYDAY USE. IDEAL FOR MANAGERIAL & EXECUTIVE OFFICE WORKSTATIONS.



### FRESH

HIGH BACK CHAIR  
FRS01 + [FABRIC]

Synchronised mechanism / Die-cast aluminium back support / 2D arms: adjustable in height & width / Adjustable lower back support / 5-Star polished aluminium base with 65mm castors / Black, brown or grey genuine leather upholstery



SitLand<sup>®</sup>

#### FABRICS



BLACK LEATHER  
[BLK]



BROWN LEATHER  
[BR]



GREY LEATHER  
[GR]

### GUEST

VISITORS CHAIR  
GST05 + [FABRIC]

Moulded foam seat & back / Chrome sleigh frame / Black nylon arm covers / Genuine leather upholstery with Eco-leather outer back available in black, brown or grey

The **FRESH** & **GUEST** chairs meet the following international standard : **CATAS Certified**.

Images shown for display purposes only. Actual finishes may vary.



**ENJOY 2B** HAS INCREDIBLE VALUE, ORGANIC CURVES, VERSATILE FRAME AND COMPLETE ADJUSTABILITY, MAKES IT ONE OF THE MOST DESIRABLE OFFICE CHAIRS ON THE MARKET.

## ENJOY 2B

TASK CHAIR  
EJB02BLK  
EJB09BLK - Optional headrest

Dual lever control mechanism with seat height, recline and locking adjustments / Height adjustable backrest with integrated lumbar support / 3D Arms adjustable in height with pivot & sliding function, with soft-touch arm pads / Optional headrest with height & angle adjustment in black mesh / 5-Star Black nylon base with 60mm castors / Black mesh upholstery



The ENJOY 2B chair meets the following international standard : is truly eco-friendly with an impressive 95% recyclability, has achieved Greenguard Indoor Air Quality Certification and meets EN1335-2:2009 and EN1335-3:2009





## ERGOHUMAN

### HIGH BACK CHAIR EH01BLK

Synchro-tilt mechanism / Single lever technology activating seat height, seat depth & back-lock adjustment / Height adjustable backrest with "Automatic Flexible Lumbar Support" system / 3D Arms adjustable in height with pivot & sliding function, with soft-touch arm pads / Seat depth adjustment / Headrest with height & angle adjustment in black 3D mesh / 5-Star Polished aluminium base with 60mm castors / Black 3D mesh upholstery



The ERGOHUMAN chair meets the following international standard : is truly eco-friendly with an impressive 97% recyclability, has achieved Greenguard Indoor Air Quality Certification and meets EN1335-2:2009 and EN1335-3:2009. In addition, it is certified to EU standard EN 5459-2:2008, for use by persons weighing up to 150kg and for use up to 24 hrs a day.

Images shown for display purposes only. Actual finishes may vary.

100%  
EXCLUSIVE



## ERGOMEDIC WITH DONDOLA® TECHNOLOGY

### HIGH BACK CHAIR

**ERG02VBLK** - Vulcan Black Fabric

**ERG02COM** - in COM[Customers Own Fabric]

**ERG09BLK** - Optional headrest

Point-synchro mechanism with Dondola® seat joint / Back structure made from flexible plastic with black breathable mesh & four elastic stabilising bands with ratchet back height adjustment / 3D Arms adjustable in height, width with sliding function & soft-touch arm pads / Ergonomically shaped foam seat with built-in seat depth & angle adjustment / Optional headrest with height & angle adjustment in black mesh / 5-Star black nylon base with 65mm castors / Seat in Vulcan black upholstery

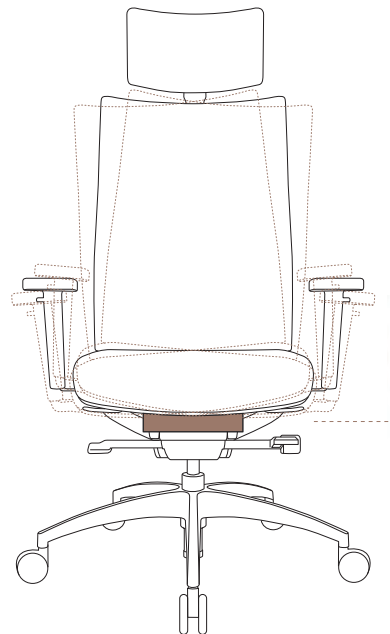

Dondola®

### THREE DIMENSIONAL DONDOLA®

Creates micro movements in the chair while sitting, which relieves pressure and strengthens the spine

The ERGOMEDIC chair meets the following international standard : **GS-label of the LGA Nuremberg and US standard ANSI BIFMA.**

Images shown for display purposes only. Actual finishes may vary.



100%  
EXCLUSIVE



## AIR

### TASK CHAIR

AR02BLK

AR09BLK - Optional headrest

DONATI Synchronised mechanism with seat slider / Backrest in black mesh with Duo T-back bars with height adjustable PU elastic lumbar support / 3D Arms adjustable in height with pivot & sliding function with soft-touch arm pads / Optional headrest with height, depth & angle adjustment in black mesh / 5-Star black nylon base with 60mm castors / Seat in standard black upholstery

The AIR chair meets the following international standard : BIFMA & GREENGUARD GOLD.

Images shown for display purposes only. Actual finishes may vary.

100%  
EXCLUSIVE



### APPRENTICE

#### HIGH BACK CHAIR APR01BLK

Synchro mechanism / Backrest with integrated headrest / V-shaped fixed arms with polyurethane armrests / 5-Star black nylon base with 50mm castors / Black leather-look upholstery



#### VISITORS CHAIR APR05BLK

Black painted sleigh frame / V-shaped fixed arms with polyurethane armrests / Black leather-look upholstery

The APPRENTICE chairs meet the following international standards : BIFMA & GREENGUARD GOLD.

as only. Actual finishes may vary.



## LUNAR

**HIGH BACK CHAIR**  
**LUN01 + [FABRIC]** - Swivel & Tilt  
**LUN06 + [FABRIC]** - Knee-tilt

Swivel & tilt or knee-tilt mechanism / Black nylon Flexi arms / 5-Star black nylon base with 50mm castors / Available in black & brown bonded leather upholstery

**MEDIUM BACK CHAIR**  
**LUN02 + [FABRIC]**

Swivel & tilt mechanism / Black nylon Flexi arms / 5-Star black nylon base with 50mm castors / Available in black & brown bonded leather upholstery

**VISITORS CHAIR**  
**LUN05 + [FABRIC]**

Black sleigh frame / Black nylon arm caps / Available in black & brown bonded leather upholstery

The **LUNAR** chairs have over 65% local manufactured content and meet the following international standards : **EN 1335-2 (Product safety and testing)** & **EN 1335-1 (Dimensioning of furniture)**.



## BOLD

**BLD01 + [FABRIC]** - High back chair  
**BLD02 + [FABRIC]** - Medium back chair

Synchronised mechanism / Black nylon height adjustable arms / Ruched back detail / 5-Star black nylon base with 50mm castors / Available in black & brown bonded leather upholstery

**VISITORS CHAIR**  
**BLD05 + [FABRIC]**

Black painted sleigh frame / Black nylon arm capping / Ruched back detail / Available in black & brown bonded leather upholstery

FABRICS



BLACK  
[BLK]



BROWN  
[BR]

100%  
EXCLUSIVE



## CHANCELLOR

CHN01BLK - High back chair  
CHN02BLK - Medium back chair

Knee-tilt mechanism / Backrest with integrated headrest / Fixed aluminium arms with leather-look padding / 5-Star aluminium base with 50mm castors / Black leather-look upholstery

The CHANCELLOR chairs meet the following international standard : BIFMA.

VISITORS CHAIR  
CHN05BLK

Chrome sleigh frame with black nylon arm covers / Black leather-look upholstery



## SOUL MATE

SLM01 + [FABRIC] - High back chair  
SLM02 + [FABRIC] - Medium back chair\*  
Not shown\*

Synchronised mechanism / Black polypropylene FLEXI arms / 5-Star black nylon base with 50mm castors / Contract black fabric or [COM]

\*Fabric requirement: 1,75m upholstery  
(0,8m seat / 0,9m back)



FABRIC  
CONTRACT BLACK  
[BLK]  
CUSTOMERS OWN MATERIAL  
[COM]

VISITORS CHAIR  
SLM05 + [FABRIC]

Black integral sleigh frame with black polypropylene arm caps / Contract black fabric or [COM]

\*Fabric requirement: 1,7m upholstery  
(0,8m seat / 0,9m back)

100%  
EXCLUSIVE

## ROYALE

### HIGH BACK CHAIR ROY01BLK

Synchronised mechanism / Chromed steel frame with fixed arms / 5-Star aluminium base with 60mm castors / Black leather-look upholstery

### MEDIUM BACK CHAIR ROY02BLK

Synchronised mechanism / Chromed steel frame with fixed arms / 5-Star aluminium base with 60mm castors / Black leather-look upholstery

The **ROYALE** chairs meet the following international standard : **BIFMA**.



100%  
EXCLUSIVE



## CLASSIC BLOCK

### HIGH BACK CHAIR CLAB01GRN

Multi-function DONATI mechanism / Aluminium fixed arms in black painted finish / 5-Star aluminium base in black painted finish with 60mm castors / Olive Green leather-look upholstery



### C-VISITORS CHAIR CVB05GRN

Steel rod sleigh frame in black painted finish / Olive Green leather-look upholstery



The **CLASSIC BLOCK** chairs meet the following international standards : **BIFMA**.

Images shown for display purposes only. Actual finishes may vary.



**CLASSICAL**, A TRUE CLASSIC CHAIR THAT FURNISHES ANY EXECUTIVE OFFICE AS WELL AS MEETING ROOMS WITH ITS SOPHISTICATED ELEGANCE.



## **CLASSICAL**

### **HIGH BACK CHAIR CLA01BLK**

Multifunction mechanism / Aluminium fixed arms in chrome / 5-Star polished aluminium base with 60mm castors / Black bonded leather upholstery

### **MEDIUM BACK CHAIR CLA02BLK**

Swivel & tilt mechanism / Aluminium fixed arms in chrome / 5-Star polished aluminium base with 60mm castors / Black bonded leather upholstery

### **MEETING CHAIR CLA04BLK**

Swivel & tilt mechanism / Aluminium fixed arms in chrome / 4-Star aluminium base on glides / Black bonded leather upholstery

### **C-VISITORS CHAIR CVC05BLK**

Steel rod sleigh frame in chrome finish / Black leather-look upholstery





### **CLASSICAL SAND/SILVER**

**CLA01SD** - High back chair  
**CLA02SD** - Medium back chair

High back with multifunction mechanism / Medium back with swivel & tilt mechanism / Aluminium fixed arms in silver painted finish / 5-Star aluminium base in silver painted finish / Sand bonded leather upholstery



### **CLASSICAL WHITE/CHROME**

**CLA01WH** - High back chair  
**CLA02WH** - Medium back chair

High back with multifunction mechanism / Medium back with swivel & tilt mechanism / Aluminium fixed arms in chrome / 5-Star base / White bonded leather upholstery



### **CLASSICAL GREY/BLACK**

**CLA01GR** - High back chair  
**CLA02GR** - Medium back chair

High back with multifunction mechanism / Medium back with swivel & tilt mechanism / Aluminium fixed arms in black painted finish / 5-Star aluminium base in black painted finish / Grey bonded leather upholstery

### **C-VISITORS CHAIR CVB05GR**

with steel rod sleigh frame in black painted finish / Grey leather-look upholstery



100%  
EXCLUSIVE

**SKIPPER**, GENERATES A CLEAN AND ESSENTIAL SEAT WITH ITS CONTINUOUS CURVED LINES, PERFECT FOR ANY HOME OFFICE OR MEETING ROOM.



### **SKIPPER EXEC HIGH BACK**

**SKPB011BLK** - Black leather

Synchronised mechanism / Moulded foam seat & back / 5-Star polished aluminium base with 50mm castors / Black genuine leather upholstery



## SKIPPER HIGH BACK

SKPB01BLK - Black leather  
 SKPB01GR - Grey leather  
 SKP01GR - Grey fabric

Synchronised mechanism / Moulded foam seat & back / 5-Star polished aluminium base with 50mm castors / Black or grey genuine leather upholstery / Grey fabric upholstery



## MESSI

MEETING CHAIR  
 MES04BLK

Cable control mechanism / Black plastic back support bars / Aluminium fixed arms in black painted finish / 5-Star black nylon base with 60mm castors / Black mesh upholstery



**LOOP**, IS CHARACTERISED BY SHARP CLEAN LINES WITH WELL-BALANCED PROPORTIONS AND FUNCTIONALITY. ITS ELEGANT DESIGN MAKES THE LOOP SUITABLE FOR ALL AREAS OF THE OFFICE AS WELL AS FOR USE IN THE HOME OFFICE.



## LOOP

TASK CHAIR

LP01BLK

LP09BLK - Optional fabric headrest

LP09PUBLK - Optional PU headrest

DONATI Dopo weight sensitive mechanism / Backrest in black mesh / 3D Arms adjustable in height with pivot & sliding function / 5-Star black nylon base with 60mm castors / Optional headrest with height adjustment in black fabric or PU / Moulded foam seat upholstered in standard black fabric

The LOOP chair meets the following international standards : BIFMA & GREENGUARD GOLD.

Images shown for display purposes only. Actual finishes may vary.



## ARCO

TASK CHAIR  
ARC02GR

ARC09GR - Optional headrest

Synchronised mechanism including seat slider / Backrest in grey mesh with high density foam lumbar support, with dual height adjustment / 3D Arms adjustable in height with pivot & sliding function with soft-touch arm pads / 5-Star black nylon base with 60mm castors / Optional headrest with height & angle adjustment in grey mesh / Moulded foam seat upholstered in standard grey fabric

The ARCO chair meets the following international standards : BIFMA & GREENGUARD GOLD.

Images shown for display purposes only. Actual finishes may vary.

100%  
EXCLUSIVE



## VIVO

TASK CHAIR

VV01BLK

VV09BLK - Optional headrest

Knee-tilt mechanism / Backrest in black mesh with PU lumbar support / Height adjustable arms / Optional headrest with height & angle adjustment in black fabric / 5-Star black nylon base with 60mm castors / Seat upholstered in standard black fabric

The VIVO chair meets the following international standards :  
**BIFMA & GREENGUARD GOLD.**



## DHL

TASK CHAIR

DHL01BLK

DHL09BLK - Optional headrest

Synchro-tilt mechanism / Backrest in black mesh with height adjustable lumbar support / 3D Arms adjustable in height with pivot and sliding function with soft-touch arm pads / Optional headrest with height & angle adjustment in black fabric / 5-Star black nylon base with 60mm castors / Seat upholstered in standard black fabric

The DHL chair meets the following international standards : **BIFMA.**



## WIN

### TASK CHAIR WIN01BLK

Synchro-tilt mechanism / Backrest in black mesh / Height adjustable arms / 5-Star black nylon base with 50mm castors / Seat upholstered in standard black fabric

The **WIN** chair meets the following international standards : **BIFMA**.



### VISITORS CHAIR WIN05BLK

Black sleigh frame / Backrest in black mesh / Fixed arms / Seat upholstered in standard black fabric

## TWIN

### TASK CHAIR TWIN01BLK

Synchronised mechanism / Height adjustable back with lumbar support / Height adjustable arms / Moulded foam seat / 5-Star black nylon base / Upholstered in standard black fabric



The **TWIN** chair meets the following international standards : **BIFMA**.

Images shown for display purposes only. Actual finishes may vary.

100%  
EXCLUSIVE



SIMPLE MECHANISM



SYNCHRONISED MECHANISM

## CHIC BLACK

### SIMPLE MECHANISM

CH02BLK

CH09BLK - Optional headrest

### SYNCHRONISED MECHANISM

CH01BLK

CH09BLK - Optional headrest

Available with simple mechanism or synchronised mechanism / Suspended backrest in black mesh / 3D Arms adjustable in height and width with sliding function / Soft-touch arm pads / Optional headrest with height and angle adjustment in black mesh / 5-Star black nylon base with 60mm castors / Seat upholstered in standard black fabric



The **CHIC BLACK** chair meets the following international standard : **BIFMA & GREENGUARD GOLD**.

Images shown for display purposes only. Actual finishes may vary.





The **CHIC LIGHT GREY** chair meets the following international standard : **BIFMA & GREENGUARD GOLD**.  
Images shown for display purposes only. Actual finishes may vary.



## **CHIC LIGHT GREY**

**SIMPLE MECHANISM**  
**CH02GR**  
**CH09GR** - Optional headrest

Simple mechanism / Suspended backrest in light grey mesh / 3D Arms adjustable in height and width with sliding function / Soft-touch arm pads / Optional headrest with height and angle adjustment in grey mesh / 5-Star light grey nylon base with 60mm castors / Seat upholstered in standard grey fabric





### **GIRO BLACK** SIMPLE MECHANISM

**GIR02BLK**  
**GIR09BLK** - Optional headrest

Simple Mechanism / Backrest in black mesh / Height adjustable arms / Optional headrest with height & angle adjustment in black fabric / 5-Star black nylon base with 50mm castors / Seat upholstered in standard black fabric



### **GIRO BLACK** KNEE-TILT MECHANISM

**GIR01BLK**  
**GIR09BLK** - Optional headrest

Knee-tilt mechanism / Backrest in black mesh / Height adjustable arms / Optional headrest with height & angle adjustment in black fabric / 5-Star black nylon base with 50mm castors / Seat upholstered in standard black fabric



The **GIRO BLACK** chair meets the following international standard : **BIFMA & GREENGUARD GOLD**.

Images shown for display purposes only. Actual finishes may vary.





## GIRO LIGHT GREY SIMPLE MECHANISM

BLACK MESH / BLACK SEAT  
GIR02GRBLK

GREY MESH / GREY SEAT  
GIR02GR

Simple mechanism / Backrest in black or grey mesh /  
Height adjustable arms / 5-Star light grey nylon base  
with 60mm castors / Seat upholstered in standard black  
or grey fabric



The **GIRO LIGHT GREY** chair meets the following international standard : **BIFMA & GREENGUARD GOLD**.

Images shown for display purposes only. Actual finish



100%  
EXCLUSIVE



## ASTRO

TASK CHAIR  
AST02BLK  
AST09BLK - Optional headrest

Simple mechanism / Backrest in black mesh with adjustable lumbar support / Fixed loop arms / Optional height adjustable headrest in black fabric / 5-Star black nylon base with 50mm castors / Seat upholstered in standard black fabric

The **ASTRO** chair meets the following international standards : **BIFMA & GREENGUARD GOLD.**

Images shown for display purposes only. Actual finishes may vary.



100%  
EXCLUSIVE

24  
MONTHS

## SHIELD

TASK CHAIR  
SHD02BLK

Simple mechanism / Suspended backrest in black mesh / Height adjustable arms / 5-Star black nylon base with 50mm castors / Seat upholstered in standard black fabric



The SHIELD chair meets the following international standards : GREENGUARD.

Images shown for display purposes only. Actual finishes may vary.



**LOCAL IS LEKKER**, OUR LOCALLY MANUFACTURED, HOME GROWN WIDE RANGE OF PROUDLY MADE IN SOUTH AFRICA OFFICE CHAIRS, MAKES THESE EXTREMELY AFFORDABLE HIGH-PERFORMANCE TASK CHAIRS — BETTER THAN EVER.



FABRIC  
 CONTRACT BLACK [BLK]  
 CUSTOMERS OWN MATERIAL [COM]

**PEZA**

**HIGH BACK CHAIR  
 PZ01 + [FABRIC]**

Swivel & tilt mechanism / 5-Star black nylon base on 50mm castors / Upholstered in Contract black fabric or [COM]

\*Fabric requirement: 1,5m upholstery (0,7m seat / 0,8m back)

**MEDIUM BACK CHAIR  
 PZ02 + [FABRIC]\***  
 Not shown

Swivel & tilt mechanism / Fixed steel arms with black nylon arm capping / 5-Star black nylon base on 50mm castors / Upholstered in Contract black fabric or [COM]

\*Fabric requirement: 1,3m upholstery (0,7m seat / 0,6m back)

**VISITORS CHAIR  
 PZ04 + [FABRIC] - Without arms  
 PZ05 + [FABRIC] - With arms**

Sleigh frame in black painted finish / Optional fixed steel arms with black nylon arm capping / Upholstered in Contract black fabric or [COM]

\*Fabric requirement: 1,3m upholstery (0,7m seat / 0,6m back)



FABRIC  
 CONTRACT BLACK [BLK]  
 CUSTOMERS OWN MATERIAL [COM]

**FLAMINGO**

**HIGH BACK CHAIR  
 FLGH01 + [FABRIC] - Without arms  
 FLGH02 + [FABRIC] - With arms**

Clutch mechanism / Optional fixed nylon arms / 5-Star black nylon base on 50mm castors / Upholstered in Contract black fabric or [COM]

\*Fabric requirements : 1,5m upholstery (0,75m seat / 0,8m back)

**MEDIUM BACK CHAIR  
 FLGM01 + [FABRIC] - Without arms  
 FLGM02 + [FABRIC] - With arms**

Clutch mechanism / Optional fixed nylon arms / 5-Star black nylon base on 50mm castors / Upholstered in Contract black fabric or [COM]

\*Fabric requirements : 1,3m upholstery (0,75m seat / 0,6m back)

**DRAUGHTSMAN  
 FLGD10 + [FABRIC]\***  
 Not shown

Clutch mechanism / Fixed nylon arms / 5-Star black nylon base on 50mm castors / Upholstered in Contract black fabric or [COM]

\*Fabric requirements : 1,3m upholstery (0,75m seat / 0,6m back)



100%  
EXCLUSIVE



## PRIMARY

VISITORS CHAIR  
**PR06BBLK** - Black frame  
**PR06BLK** - Chrome frame

Black or chrome 4-legged frame / Black mesh back / Black nylon arms / Stackable / Seat upholstered in standard black fabric

100%  
EXCLUSIVE



## SLING

VISITORS CHAIR  
**SLB05BLK** - Black frame  
**SL05BLK** - Chrome frame

Black or chrome 4-legged frame / Black mesh back / Black nylon arms / Stackable / Seat upholstered in standard black fabric



**ALINA**, A CONVENIENT, COMFORTABLE, STACKABLE CHAIR IDEAL FOR WAITING AREAS, CONFERENCE ROOMS AND AS A VISITOR CHAIR. AVAILABLE WITH A CHROMED OR BLACK PAINTED FRAME WITH A MESH OPTION FOR THE BACK TO COMPLETE THE RANGE.



### ALINA MESH

#### VISITORS CHAIR

ALM05B + [FABRIC] - Black frame  
ALM05C + [FABRIC] - Chrome frame

Integral sleigh frame available in chrome or black painted finish / Armrest covers in tubular black sponge / Black mesh back / Seat upholstered in Vulcan black fabric or [COM]

\*Fabric requirements : 1,5m upholstery (0,7m seat / 0,7m back)

### ALINA UPHOLSTERED

#### VISITORS CHAIR

AL05B + [FABRIC] - Black frame  
AL05C + [FABRIC] - Chrome frame

Integral sleigh frame available in chrome or black painted finish / Armrest covers in tubular black sponge / Black polypropylene outer back / Seat & back upholstered in Vulcan black fabric or [COM]



FABRIC



CUSTOMERS OWN MATERIAL [COM]

The ALINA chairs meet the following international standards : CATAS Certified.

Images shown for display purposes only. Actual finishes may vary.

24  
MONTHS



## SUPREME

VISITORS CHAIR  
SPRM05BLK - Mesh back

Chrome sleigh frame with black nylon arm capping / Black mesh back / Seat upholstered in standard black fabric

100%  
EXCLUSIVE

MADE IN  
SOUTH  
AFRICA



## KEY

VISITORS CHAIR  
UN05B + [FABRIC] - Black frame  
UN05C + [FABRIC] - Chrome frame  
UN05 + [FABRIC] - Silver frame

Chrome, black or silver painted sleigh frame with black arm capping / Moulded foam seat & back / Upholstered in Vulcan fabric [V] or [COM]

\*Fabric requirements : 1,5m upholstery (0,75m seat / 0,65m back)



FABRICS



VULCAN FABRICS  
[V]

Vulcan fabric colour to be  
specified on order



CUSTOMERS OWN MATERIAL  
[COM]

The KEY chair has 100% local manufactured content.  
Images shown for display purposes only. Actual finishes may vary.



100%  
EXCLUSIVE

**UNIQUE**, IS SIMPLE AND ELEGANT. IT CAN SEAMLESSLY FIT INTO ALMOST ANY SPACE, FROM BOARDROOMS TO MEETING SPACES OR A PIECE ON ITS OWN.



## UNIQUE

UNQ05 + [FABRIC]

Moulded shell reinforced with inner steel frame / Black 4-legged frame / Standard amber or midnight blue PU upholstery

FABRICS



AMBER  
[AMB]



MIDNIGHT BLUE  
[MBL]



100%  
EXCLUSIVE

**ALCE**, SIMPLE AND ELEGANTLY RETRO IN DESIGN WITH GREAT COMFORT. IT HAS THE PERFECT COMBINATION OF FINE MATERIALS AND EXQUISITE SEWING TECHNOLOGY.



## ALCE

ALC05 + [FABRIC]

Moulded shell reinforced with inner steel frame / Black four-legged frame / Standard amber or midnight blue PU upholstery

FABRICS



AMBER  
[AMB]



MIDNIGHT BLUE  
[MBL]



**LOBBY**, IS A SMALL MULTI-PURPOSE TUB THAT SITS WELL AT ANY BOARDROOM OR MEETING TABLE AS WELL AS ON ITS OWN. AVAILABLE IN A CHOICE OF THREE UNDERSTATED FABRIC OPTIONS.



DESERT SAND  
[DS]



DARK GREY  
[DGR]



LIGHT GREY  
[LGR]

### LOBBY 5-STAR SWIVEL

LBY04 + [FABRIC]

Moulded shell reinforced with inner steel frame / Swivel and gas height adjustment / DONATI 5-star polished aluminium base with 60mm castors / Standard desert sand, dark grey or light grey upholstery



DESERT SAND  
[DS]



DARK GREY  
[DGR]



LIGHT GREY  
[LGR]

### LOBBY 4-STAR MEETING

LBY01 + [FABRIC]

Moulded shell reinforced with inner steel frame / Swivel and gas height adjustment / 4-Star polished aluminium base / Standard desert sand, dark grey or light grey upholstery



GREY  
[GR]



GREEN  
[GRN]



ORANGE  
[OR]

## CHAT ARMCHAIR

### CH01 + [FABRIC]

620 (W) x 600 (D) x 750 (H) x 490 (SH)

Moulded shell reinforced with inner steel frame / Solid Ash wood base in natural finish / Standard grey, green or orange upholstery



## NUK 4-STAR SWIVEL ON GLIDES

### SIDE CHAIR

NKA04BG + [COM] - Black frame  
NK04CG + [COM] - Chrome frame  
NK04WG + [COM] - White frame

### ARMCHAIR

NKA04BG + [COM] - Black frame  
NKA04CG + [COM] - Chrome frame  
NKA04WG + [COM] - White frame

Moulded foam shell upholstered in [COM] / 4-Star swivel base on glides in black, chrome & white

\*Fabric requirement: 1m outer shell upholstery / 0,5m seat upholstery



## NUK 4-STAR SWIVEL ON CASTORS

### SIDE CHAIR

NKA04BC + [COM] - Black frame  
NK04CC + [COM] - Chrome frame  
NK04WC + [COM] - White frame

### ARMCHAIR

NKA04BC + [COM] - Black frame  
NKA04CC + [COM] - Chrome frame  
NKA04WC + [COM] - White frame

Moulded foam shell upholstered in [COM] / 4-Star swivel base on castors in black, chrome & white



FABRICS



OATMEAL  
[ML]



BLACK  
[BLK]



GREY  
[GR]





**ROLF'S**, ERGONOMIC DESIGN CREATES A COMFORTABLE SITTING EXPERIENCE. THE SOFT FLOWING LINES ADD AN ELEGANT TOUCH TO ITS MODERN DESIGN.



### ROLF 4-STAR SWIVEL

RLF04 + [FABRIC]

Moulded shell reinforced with inner steel frame / 4-Star swivel base in black with 50m castors / Standard oatmeal or black PU upholstery / Standard grey fabric upholstery



### ROLF SLEIGH

RLF05 + [FABRIC]

Moulded shell reinforced with inner steel frame / Black sleigh frame / Standard oatmeal or black PU upholstery / Standard grey fabric upholstery



### **INDUSTRIAL HIGH REACH CHAIR**

**IN07BLK** - Chrome foot ring  
**IN07NBLK** - Nylon foot ring

Permanent contact clutch mechanism - backrest tilts, seat does not / Black polyurethane seat & back / Pivoting seat / 5-Star black nylon base with glides / Height adjustable chrome or nylon foot ring



### **INDUSTRIAL CHAIR**

**IN08BLK**

Permanent contact clutch mechanism- backrest tilts, seat does not / Black polyurethane seat & back / Pivoting seat / 5-Star black nylon base with glides



### **INDUSTRIAL CASHIER HIGH REACH STOOL**

**IN05BLK** - Chrome foot ring  
**IN05NBLK** - Nylon foot ring

Swivel mechanism with height adjustment / Black polyurethane seat / 5-Star black nylon base with glides / Height adjustable chrome or nylon foot ring

100%  
EXCLUSIVE



## HI-REIN DRAUGHTSMAN

HRD10BLK

Self-designed mechanism / Backrest in black mesh / Height adjustable arms / 5-Star black nylon base with 60mm castors / Height adjustable chrome foot ring / Standard black fabric upholstery

The HI-REIN draughtsman meets the following international standard : GREENGUARD GOLD.  
Images shown for display purposes only. Actual finishes may vary.





**YOYO**, COMPACT AND FLEXIBLE, MAKING IT THE IDEAL CHOICE FOR SOCIAL, COLLABORATIVE SPACES. WITH ITS INNOVATIVE DESIGN AND CLEAR SIMPLE STYLE, IT WILL MAKE WORKING FUN.



### YOYO TASK

YY02B + [FABRIC]

Black polypropylene shell with soft padding / Gas-height adjustment / Height adjustable backrest / 5-Star black nylon non-slip base with 60mm castors / Upholstered in standard \*Gabriel™ dark grey, green & orange fabrics

**\*\*Gabriel™ fabrics : 100% renewable polyester, excellent durability, fire resistant & environmentally friendly.**



### YOYO DRAUGHTSMAN

YY10 + [B/LG] + [FABRIC]

Black or light grey polypropylene shell with soft padding / Gas-height adjustment / Height adjustable backrest / 5-Star black or light grey nylon non-slip base with 60mm castors / Height adjustable nylon foot ring / Upholstered in standard \*Gabriel™ dark grey, green & orange fabrics

**\*\*Gabriel™ fabrics : 100% renewable polyester, excellent durability, fire resistant & environmentally friendly.**

#### FABRICS



DARK GREY [GR]



GREEN [GRN]



ORANGE [OR]

The YOYO chairs meet the following international standards : BIFMA & GREENGUARD GOLD.

Images shown for display purposes only. Actual finishes may vary.



**ACE DRAUGHTSMAN**

**LIGHT GREY  
ACD10LGGR**

Light grey polypropylene shell / Light grey nylon 5-star base with 60mm castors / Chrome height adjustable foot ring / Seat & back upholstered in standard dark grey fabric

**BLACK  
ACD10BGR**

Black polypropylene shell / Black nylon 5-star base with 50mm castors / Chrome height adjustable foot ring / Seat & back upholstered in standard dark grey fabric



THE DESIGN OF **ACE** IS SIMPLE AND ELEGANT WITH EXTRA COMFORT AND ADVANCED ERGONOMICS. THE DISTINCTIVE OPEN LUMBAR AREA AND FLEXIBLE BACK ALLOWS THE USER TO SIT IN THE MOST COMFORTABLE POSTURE.



### **ACE** 4-STAR SWIVEL

LIGHT GREY  
AC04LGGR

Light grey shell / Fixed arms / Light grey painted 4-star base with 60mm castors / Seat & back upholstered in standard dark grey fabric



BLACK  
AC04BGR

Black polypropylene shell / Fixed arms / Black painted 4-star base with 60mm castors / Seat & back upholstered in standard dark grey fabric



### **ACE** 5-STAR SWIVEL

LIGHT GREY  
AC02LGGR

Light grey polypropylene shell / Fixed arms / Light grey nylon 5-star base with 60mm castors / Seat & back upholstered in standard dark grey fabric



BLACK  
AC02BGR

Black polypropylene shell / Fixed arms / Black nylon 5-star base with 50mm castors / Seat & back upholstered in standard dark grey fabric

The **ACE** chairs meet the following international standards : **BIFMA & GREENGUARD GOLD**.

Images shown for display purposes only. Actual finishes may vary.





100%  
EXCLUSIVE



## KICCA 4-STAR SWIVEL ON CASTORS

### BLACK BASE

KC04BC + [COLOUR]

KCSU04BC + [COLOUR] + [COM] - Upholstered seat

KCU04BC + [COLOUR] + [COM] - Upholstered inner shell

### CHROME BASE

KC04CC + [COLOUR]

KCSU04CC + [COLOUR] + [COM] - Upholstered seat

KCU04CC + [COLOUR] + [COM] - Upholstered inner shell

### WHITE BASE

KC04WC + [COLOUR]

KCSU04WC + [COLOUR] + [COM] - Upholstered seat

KCU04WC + [COLOUR] + [COM] - Upholstered inner shell

Polypropylene shell / 4-Star base on castors in black, chrome & white /  
Optional seat & inner shell upholstered in [COM] / Available in anthracite,  
black, blue, green, orange, sand, turquoise & white

\*Fabric requirements : 0,6m seat upholstery / 1,1m inner shell upholstery  
(0,6m for 2 x seats)

### KICCA COLOURS



ANTHRACITE  
[AN]



BLACK  
[BLK]



BLUE  
[BL]



GREEN  
[GRN]



ORANGE  
[OR]



SAND  
[SD]



TURQUOISE  
[TQ]



WHITE  
[WH]

## KICCA 4-STAR SWIVEL ON GLIDES

### BLACK BASE

KC04BG + [COLOUR]

KCSU04BG + [COLOUR] + [COM] - Upholstered seat pad

KCU04BG + [COLOUR] + [COM] - Upholstered inner shell

### CHROME BASE

KC04CG + [COLOUR]

KCSU04CG + [COLOUR] + [COM] - Upholstered seat pad

KCU04CG + [COLOUR] + [COM] - Upholstered inner shell

### WHITE BASE

KC04WG + [COLOUR]

KCSU04WG + [COLOUR] + [COM] - Upholstered seat pad

KCU04WG + [COLOUR] + [COM] - Upholstered inner shell

Polypropylene shell / 4-Star base on glides in black, chrome & white /  
Optional seat pad & inner shell upholstered in [COM] / Available in  
anthracite, black, blue, green, orange, sand, turquoise & white

\*Fabric requirements : 0,6m seat upholstery / 1,1m inner shell upholstery  
(0,6m for 2 x seats)



## KICCA 5-STAR SWIVEL

### ALUMINIUM BASE

KC04 + [COLOUR]

KCSU04 + [COLOUR] + [COM] - Upholstered seat pad

KCU04 + [COLOUR] + [COM] - Upholstered inner shell

### NYLON BASE

KC04N + [COLOUR]

KCSU04N + [COLOUR] + [COM] - Upholstered seat pad

KCU04N + [COLOUR] + [COM] - Upholstered inner shell

Polypropylene shell / 5-Star aluminium or nylon base with gas  
height adjustment / Optional seat pad & inner shell upholstered  
in [COM] / Available in anthracite, black, blue, green, orange,  
sand, turquoise & white

\*Fabric requirements : 0,6m seat upholstery / 1,1m inner shell upholstery  
(0,6m for 2 x seats)

The KICCA chairs meet the following international standards : CATAS Certified.

Images shown for display purposes only. Actual finishes may vary.



100%  
EXCLUSIVE



## KALEA 4-STAR SWIVEL ON CASTORS

NO UPHOLSTERY - WITH ARMS

KLA04BC + [COLOUR] - Black base  
KLA04WC + [COLOUR] - White base

SEAT UPHOLSTERY - WITH ARMS

KLASU04BC + [COLOUR] + [COM] - Black base  
KLASU04WC + [COLOUR] + [COM] - White base

NO UPHOLSTERY - WITHOUT ARMS

KL04BC + [COLOUR] - Black base  
KL04CC + [COLOUR] - Chrome base  
KL04WC + [COLOUR] - White base

SEAT UPHOLSTERY - WITHOUT ARMS

KLSU04BC + [COLOUR] + [COM] - Black base  
KLSU04CC + [COLOUR] + [COM] - Chrome base  
KLSU04WC + [COLOUR] + [COM] - White base

Polypropylene shell / With or without arms / 4-Star base on castors in black, chrome & white / Optional seat pad upholstered in [COM] / Available in black, turquoise & white

\*Fabric requirements : 0,6m seat upholstery (0,6m for 2 x seats)

### KALEA COLOURS



BLACK  
[BLK]



TURQUOISE  
[TQ]



WHITE  
[WH]

## KALEA 4-STAR SWIVEL ON GLIDES

NO UPHOLSTERY - WITH ARMS

KLA04BG + [COLOUR] - Black base  
KLA04WG + [COLOUR] - White base

SEAT UPHOLSTERY - WITH ARMS

KLASU04BG + [COLOUR] + [COM] - Black base  
KLASU04WG + [COLOUR] + [COM] - White base

NO UPHOLSTERY - WITHOUT ARMS

KL04BG + [COLOUR] - Black base  
KL04CG + [COLOUR] - Chrome base  
KL04WG + [COLOUR] - White base

SEAT UPHOLSTERY - WITHOUT ARMS

KLSU04BG + [COLOUR] + [COM] - Black base  
KLSU04CG + [COLOUR] + [COM] - Chrome base  
KLSU04WG + [COLOUR] + [COM] - White base

Polypropylene shell / With or without arms / 4-Star base on glides in black, chrome & white / Optional seat pad upholstered in [COM] / Available in black, turquoise & white

\*Fabric requirements : 0,6m seat upholstery (0,6m for 2 x seats)



## KALEA 5-STAR SWIVEL

ALUMINIUM BASE

KL04 + [COLOUR]  
KLSU04 + [COLOUR] + [COM] - Upholstered seat pad

NYLON BASE

KL04N + [COLOUR]  
KLSU04N + [COLOUR] + [COM] - Upholstered seat pad

Polypropylene shell / 5-Star aluminium or nylon swivel base with gas height adjustment / Optional seat pad upholstered in [COM] / Available in black, turquoise & white

\*Fabric requirements : 0,6m seat upholstery (0,6m for 2 x seats)

The KALEA chairs meet the following international standards : CATAS Certified.

Images shown for display purposes only. Actual finishes may vary.

100%  
EXCLUSIVE



### LA'MIA 5-STAR SWIVEL

ALUMINIUM BASE - WITH ARMS  
LMA04 + [COLOUR]  
LMA04 + [COLOUR] + [COM] - Upholstered seat

ALUMINIUM BASE - WITHOUT ARMS  
LM04 + [COLOUR]  
LM04 + [COLOUR] + [COM] - Upholstered seat

NYLON BASE - WITH ARMS  
LMA04N + [COLOUR]  
LMA04N + [COLOUR] + [COM] - Upholstered seat

NYLON BASE - WITHOUT ARMS  
LM04N + [COLOUR]  
LM04N + [COLOUR] + [COM] - Upholstered seat

Polypropylene seat & back / 5-Star swivel base in aluminium or nylon with gas height adjustment / With or without arms / Optional seat upholstered in [COM] / Available in black & white

\*Fabric requirement: 0,7m seat upholstery (0,7m for 2 x seats)

COLOURS



### LA'MIA 4-LEGGED

ARMCHAIR  
LMA06 + [COLOUR]  
LMA06 + [COLOUR] + [COM] - Upholstered seat

SIDE CHAIR  
LM06 + [COLOUR]  
LM06 + [COLOUR] + [COM] - Upholstered seat

Polypropylene seat & back / Matching 4-legged frame / With or without arms / Stackable / Optional seat upholstered in [COM] / Available in black, grey & white

\*Fabric requirement: 0,7m seat upholstery (0,7m for 2 x seats)

COLOURS



\*Featured chairs are CATAS certified.

Images shown for display purposes only. Actual finishes may vary.



### LA'FILO 5-STAR SWIVEL

ALUMINIUM BASE - WITH ARMS  
LFA04B + [COLOUR] - Black frame  
LFA04B + [COLOUR] + [COM] - Black frame

LFA04 + [COLOUR] - Chrome frame  
LFA04 + [COLOUR] + [COM] - Chrome frame

ALUMINIUM BASE - WITHOUT ARMS  
LF04B + [COLOUR] - Black frame  
LF04B + [COLOUR] + [COM] - Black frame

LF04 + [COLOUR] - Chrome frame  
LF04 + [COLOUR] + [COM] - Chrome frame

NYLON BASE - WITH ARMS  
LFA04NB + [COLOUR] - Black frame  
LFA04NB + [COLOUR] + [COM] - Black frame

LFA04N + [COLOUR] - Chrome frame  
LFA04N + [COLOUR] + [COM] - Chrome frame

NYLON BASE - WITHOUT ARMS  
LF04NB + [COLOUR] - Black frame  
LF04NB + [COLOUR] + [COM] - Black frame

LF04N + [COLOUR] - Chrome frame  
LF04N + [COLOUR] + [COM] - Chrome frame

Black or chrome frame with polypropylene seat & back / 5-Star swivel base in aluminium or nylon with gas height adjustment / With or without arms / Optional seat & back upholstered in [COM] / Available in black, blue, grey, sand & white

\*Fabric requirement: 1,1m seat & back upholstery

#### COLOURS



BLACK [BLK]



BLUE [BL]



GREY [GR]



SAND [SD]



WHITE [WH]



### LA'FILO SLEIGH

ARMCHAIR  
LFA06B + [COLOUR] - Black frame  
LFAU06B + [COLOUR] + [COM] - Black frame

LFA06 + [COLOUR] - Chrome frame  
LFAU06 + [COLOUR] + [COM] - Chrome frame

SIDE CHAIR  
LF06B + [COLOUR] - Black frame  
LFU06B + [COLOUR] + [COM] - Black frame

LF06 + [COLOUR] - Chrome frame  
LFU06 + [COLOUR] + [COM] - Chrome frame

Black or chrome sleigh frame with polypropylene seat & back / With or without arms / Stackable / Optional seat & back upholstered in [COM] / Available in black, blue, grey, sand & white

\*Fabric requirement: 1,1m seat & back upholstery

\*Featured chairs are CATAS certified.

Images shown for display purposes only. Actual finishes may vary.

100%  
EXCLUSIVE



**ECLIPSE** WITH ITS CONTINUOUS CURVED LINE, GENERATING A CLEAN AND ESSENTIAL SEAT, WHICH CONVEYS LIGHTNESS.



## ECLIPSE WIRE

**PAINTED FRAMES**  
**ECW06BLK** - Black frame  
**ECW06WH** - White frame  
\*Suitable for outdoor use

**CHROME FRAME**  
**ECW06CH**

Steel rod construction /  
Available in black or  
white painted finish  
or chrome

The **ECLIPSE WIRE** chairs are **SPECIAL IMPORT**. Enquire about stock & import lead times.



The **ECLIPSE** chairs meet the following international standards: **CATAS Certified**.

Images shown for display purposes only. Actual finishes may vary.



## **ECLIPSE 5-STAR SWIVEL**

### **ALUMINIUM BASE**

**EC04 + [COLOUR]**

**ECSU04 + [COLOUR] + [COM]** - Upholstered seat

### **NYLON BASE**

**EC04N + [COLOUR]**

**ECSU04N + [COLOUR] + [COM]** - Upholstered seat

Fibreglass-reinforced polypropylene shell / 5-Star swivel base in Aluminium or Nylon with gas height adjustment / Optional seat upholstered in [COM] / Available in anthracite, antique rose, light grey, mint, rust & white

\*Fabric requirements : 0,6m seat upholstery (0,6m for 2 x seats)



## **ECLIPSE SLEIGH**

### **BLACK FRAME**

**ECB06 + [COLOUR]**

**ECBSU06 + [COLOUR] + [COM]** - Upholstered seat

### **CHROME FRAME**

**EC06 + [COLOUR]**

**ECSU06 + [COLOUR] + [COM]** - Upholstered seat

Fibreglass-reinforced polypropylene shell / Sleigh frame in black or chrome / Optional seat upholstered in [COM] / Available in anthracite, antique rose, light grey, mint, rust & white

\*Fabric requirements : 0,6m seat upholstery (0,6m for 2 x seats)

### COLOURS









# ACOUSTICS



FINDING A RESERVED SPACE IN WHICH TO MAKE A CALL WITHOUT BEING DISTURBED BY SURROUNDING NOISE IS EASY WITH **MUTEBOX PHONE**. FITTED WITH A NARROW STANDING HEIGHT SHELF, THIS COMPACT SOLUTION FOR ONE PERSON IS PRACTICAL AND COMFORTABLE.

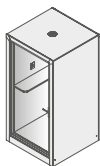

**MUTEBOX** PHONE

**TWO SOLID SIDES**  
**MBP1212-2-CN-COM**  
 1200 (L) x 1200 (W) x 2300 (H)

\*[COM] Fabric Requirements : 2,4m



**THREE SOLID SIDES**  
**MBP1212-3-CN-COM**  
 1200 (L) x 1200 (W) x 2300 (H)

\*[COM] Fabric Requirements : 4,8m

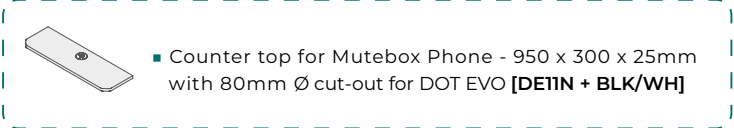

■ Counter top for Mutebox Phone - 950 x 300 x 25mm with 80mm Ø cut-out for DOT EVO [DE11N + BLK/WH]



**MUTEBOX FOCUS**, IS DESIGNED TO ACCOMMODATE A SINGLE PERSON IN A PRIVATE SPACE FOR SHORT PERIODS OF CONCENTRATION FOR VIDEO MEETINGS OR FOCUSED WORK. THIS SOLUTION FOR ONE PERSON IS PRACTICAL AND COMFORTABLE.

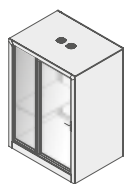

**MUTEBOX FOCUS**

**TWO SOLID SIDES**  
**MBF1612-2-CN-COM**  
 1600 (L) x 1200 (W) x 2300 (H)

\*[COM] Fabric Requirements : 2,4m

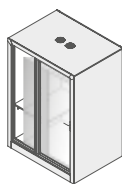

**THREE SOLID SIDES**  
**MBF1612-3-CN-COM**  
 1600 (L) x 1200 (W) x 2300 (H)

\*[COM] Fabric Requirements : 7,2m

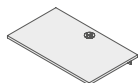

■ Desktop for Mutebox Focus - 1012 x 600 x 25mm with 80mm Ø cut-out for DOT EVO [DE11N + BLK/WH]



**MUTEBOX MEETING SMALL**, A PRIVACY POD WHERE TWO PEOPLE CAN MEET COMFORTABLY. DESKTOP POWER IN THE MEETING TABLE ALLOWS TO EASILY RECHARGE PC'S, TABLETS AND SMARTPHONES.



IN LARGE SPACES THERE IS A NEED TO ISOLATE ONESELF FOR A CALL OR A PRIVATE MEETING, OR SIMPLY TO FIND A SPACE FOR CONCENTRATION. THE **MUTEBOX** COLLECTION WAS DESIGNED TO CREATE THESE MUCH NEEDED SPACES OF PRIVACY AND COMFORT.

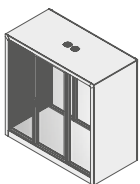

**MUTEBOX MEETING SMALL**

TWO SOLID SIDES  
**MBM2412-2-CN-COM**  
2400 (L) x 1200 (W) x 2300 (H)

\*[COM] Fabric Requirements : 4,8m

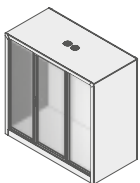

THREE SOLID SIDES  
**MBM2412-3-CN-COM**  
2400 (L) x 1200 (W) x 2300 (H)

\*[COM] Fabric Requirements : 7,2m

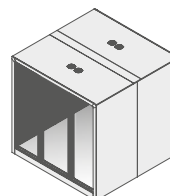

**MUTEBOX MEETING LARGE**

TWO SOLID SIDES  
**MBM2424-2-CN-COM**  
2400 (L) x 2400 (W) x 2300 (H)

\*[COM] Fabric Requirements : 4,8m

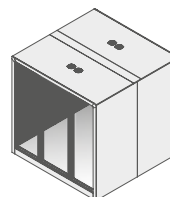

THREE SOLID SIDES  
**MBM2424-3-CN-COM**  
2400 (L) x 2400 (W) x 2300 (H)

\*[COM] Fabric Requirements : 9,6m



■ Jetty worktop for Mutebox Meeting Small - 900 - 560 x 600 x 25mm with 80mm Ø cut-out for DOT EVO [DETIN + BLK/WH] includes black rectangular pole leg

**MUTEBOX MEETING LARGE**, ACCOMMODATES UP TO 4 PEOPLE. THIS MUTE BOX OFFERS AN OPEN BOX FOR YOUR CHOICE OF FURNITURE SYSTEMS. AN INTEGRATED DOT EVO POWER SET IS SUPPLIED WITH ACCESS TO POSITION AT TABLE OR BAR HEIGHT, FITTED TO THE MIDDLE OF THE FABRIC WALL.



#### FEATURES:

- Designed to be dismantled & reassembled within 6-7 hours
- The Mutebox pods are not sound proof, but have sound absorption properties
- Mutebox Phone, Focus & Meeting Small are easily moveable - fitted with industrial castors
- Glazed door: 6,38mm laminated glass in black aluminium frame
- Interior: Sound absorption infill panels in Customers Own Material [COM], with at least one wall cladded in 4Akustik® 13/3 oak melamine faced MDF panels.
- Exterior: Laminate panels available in CN Exclusive Laminates, Anthracite, Black, Stone Grey & White
- Ceiling: Anthracite laminate
- Vanguard Canvas 50cm x 50cm carpet tiles in Tapestry Grey.
- Ventilation by means of high performance low-noise fans providing 20-30 airchanges/hour
- Operated by manual switch
- Counter top, worktop or Jetty table included in Mutebox Phone, Focus & Meeting Small. All include 80mm Ø cut-out, centrally positioned, for DOT EVO [DETIN + BLK/WH], to be ordered separately

One internal wall of all our MUTEBOX pods is cladded with 4Akustik® panels on top of 30mm thick acoustic wool. 4Akustik® is highly absorbent of medium frequency and the acoustic wool absorbs higher frequency. This combination is highly effective in preventing reverberation.

Images shown for display purposes only. Actual finishes may vary.



**4AKUSTIK® WALL PANELS** ARE EXCEPTIONALLY EFFICIENT IN ABSORBING SOUND AND REDUCING REVERBERATION AS A RESULT. IT CREATES A COMFORTABLE AND CALMING AMBIANCE MAKING COMMUNICATION BETWEEN PEOPLE CLEAR AND UNCLUTTERED.

## 4AKUSTIK® WALL PANELS

### **4AKU4025**

4000 (L) x 2500 (H) x 16mm

### **4AKU8025**

8000 (L) x 2500 (H) x 16mm

The installation of the wall panels is subject to an installation charge which will be quoted separately per project depending on the site location and specification.

## ACOUSTIC WOOL

### **ACW13**

13,0m (L) x 1,2m (W) x 50mm

\*Sold per roll



## **FEATURES:**

- Workspaces with poor acoustics and excessive reverberation can be very distracting causing people to be unproductive. 4Akustik® panels have significant benefits to address this problem in areas where people gather, e.g., meeting rooms, open plan offices and cafeterias.
- 4Akustik® panels are manufactured from medium density fibreboard (MDF) which is machined into a scientifically developed sound absorbent. It works on the Helmholtz resonator principle, i.e., a high number of holes milled into the MDF in which sound waves dissipate. These resonators are extremely effective in the absorption of medium range frequencies.
- Between the 4Akustik® panels and the wall to which it is applied, a layer 30mm thick acoustic wool is installed. The acoustic wool with its porous textures absorbs a higher range of frequencies. The combination of medium and high frequency absorbers reduce reverberation by up to 90% making it one of the best solutions to address poor acoustics in the workplace.
- 4Akustik® panels comply with the highest global health and safety standards and are E1 certified for use in an office environment, i.e., compliant with European standards of formaldehyde content.



**MUTE CEILING TILES**, ARE SPECIALLY DESIGNED FOR A MODERN SUSPENDED CEILING GRID. THESE LIGHTWEIGHT POLYESTER CEILING TILES REDUCE REVERBERATION AND INCREASE SOUND ABSORPTION IN THE OPEN PLAN ENVIRONMENT.

**MUTE CEILING TILES**

**MCT6060 + [COLOUR]** - 595 (L) x 595(H) x 9mm  
**MCT6012 + [COLOUR]** - 1195 (L) x 595 (H) x 9mm

9mm 100% Recyclable Polyester panel / Fits into standard ceiling grid / Available in Anthracite, Black, Cloud Blue, Leaf Green, Marble, Lime, Sage Green, Serenity Blue or Slate Grey

100% POLYESTER COLOURS

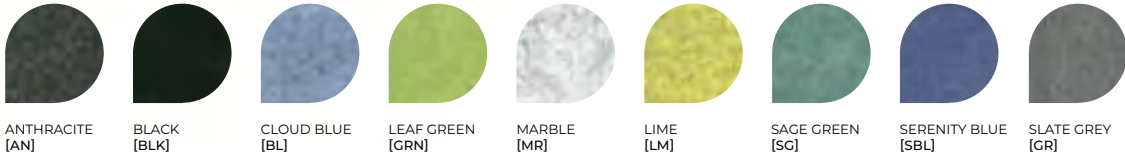

100% Polyester is extremely durable and requires little attention to maintain. Light dusting on a regular basis will prevent dust build up. Most marks can be cleaned with a mild detergent solution, followed by rinsing and blotting.



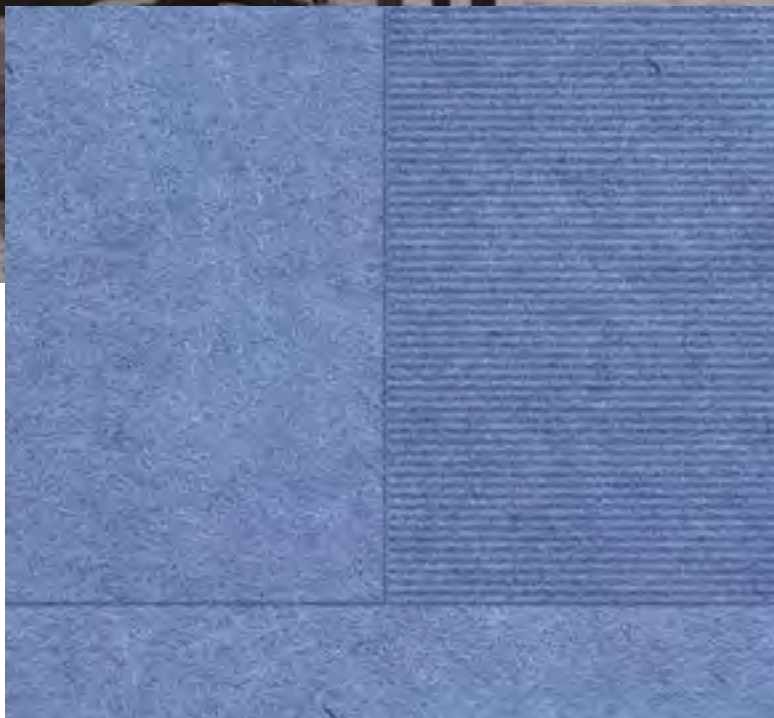

**MUTE WALL TILES**, ARE LIGHTWEIGHT WALL MOUNTED ACOUSTIC SOUND ABSORBING PANELS THAT ARE PERFECT BUFFERS FOR ECHO AND REVERBERATION IN YOUR OFFICE OR MEETING SPACE. AVAILABLE WITH A PLAIN SURFACE OR WITH A V-GROOVE PATTERN THAT CAN CREATE A CHECKERBOARD PATTERN.

## MUTE WALL TILES

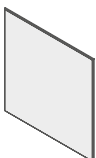

PLAIN  
**MWT6060 + [COLOUR]** - 600 (L) x 600 (H) x 9mm  
**MWT6012 + [COLOUR]** - 600 (L) x 1200 (H) x 9mm



V-GROOVE  
**MWTV6060 + [COLOUR]**  
 600 (L) x 600 (H) x 9mm

9mm 100% Recyclable Polyester panel with bevelled edges / Striped tiles have V-groove lines allowing you to place horizontally or vertically to create your own patterns / Fitted to wall with high tack adhesive (not supplied) / Available in Anthracite, Black, Cloud Blue, Leaf Green, Marble, Lime, Sage Green, Serenity Blue or Slate Grey

Images shown for display purposes only. Actual finishes may vary.



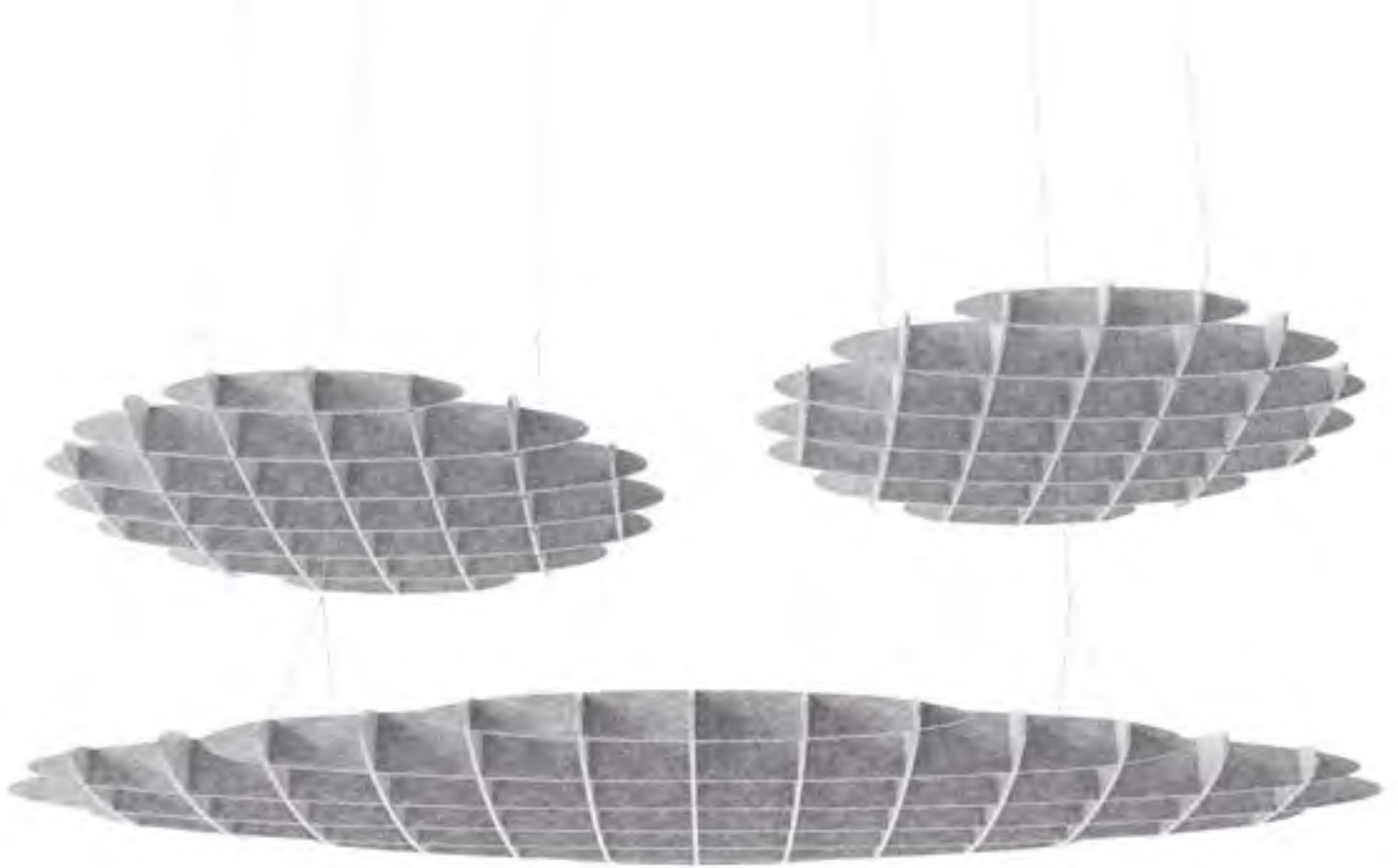

**MUTE BAFFLE** IS A POWERFUL ACOUSTIC STRUCTURE THAT IS EYE-CATCHING WHEATHER PLACED IN LONG PASSAGeways OR AS A CENTREPIECE IN BOARDROOMS OR OPEN-PLAN OFFICES. THESE ACOUSTIC BAFFLES ARE SOUND ABSORBANT AND ITS OPEN DESIGN LETS LIGHT THROUGH.

## MUTE BAFFLES

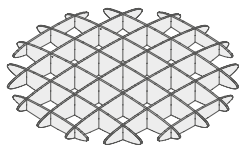

**MB1212 + [COLOUR]**  
1200 (L) x 1200 (W) x 150mm (H)

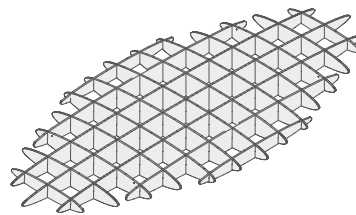

**MB2412 + [COLOUR]**  
2400 (L) x 1200 (W) x 150mm (H)

9mm 100% Recyclable polyester material / Includes Gripple® hanging fittings allowing 600mm suspension from ceiling / Includes ceiling hanging clips for standard ceiling grids / Available in Anthracite, Black, Cloud Blue, Leaf Green, Marble, Lime, Sage Green, Serenity Blue or Slate Grey

### 100% POLYESTER COLOURS



ANTHRACITE  
[AN]



BLACK  
[BLK]



CLOUD BLUE  
[BL]



LEAF GREEN  
[GRN]



MARBLE  
[MR]



LIME  
[LM]



SAGE GREEN  
[SG]



SERENITY BLUE  
[SBL]



SLATE GREY  
[GR]

100% Polyester is extremely durable and requires little attention to maintain. Light dusting on a regular basis will prevent dust build up. Most marks can be cleaned with a mild detergent solution, followed by rinsing and blotting.



**MUTE HORIZONTAL** WILL TRANSFORM YOUR CEILING INTO A SOUND ABSORBING PIECE OF ART WITH ACOUSTIC PANELS IN VARIOUS SHAPES AND SIZES. THEY ARE EASILY SUSPENDED WITH A GRIPPLE WIRE SUSPENSION KIT THAT ALLOWS THE PANELS TO HANG 600MM FROM THE CEILING, BUT CAN EASILY BE ADJUSTED IN LENGTH. LIGHTWEIGHT AND VISUALLY APPEALING FOR ALL HIGH ACTIVITY NOISY ENVIRONMENTS.

### MUTE HORIZONTAL

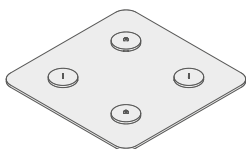

**SQUARE**  
**MSH6060 + [COLOUR]** - 600 (W) x 600 (D) x 9mm  
**MSH8080 + [COLOUR]** - 800 (W) x 800 (D) x 9mm

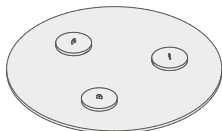

**ROUND**  
**MSH600 + [COLOUR]** - 600 Ø x 9mm  
**MSH800 + [COLOUR]** - 800 Ø x 9mm  
**MSH1200 + [COLOUR]** - 1200 Ø x 9mm

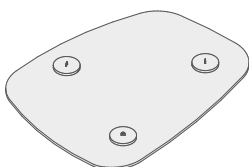

**OBLONG**  
**MSH8969 + [COLOUR]** - 890 (W) x 690 (D) x 9mm

9mm 100% Recyclable polyester panel with 3mm MDF hanging discs with brackets / Includes Gripple® hanging fittings allowing 600mm suspension from ceiling / Includes ceiling hanging clips for standard ceiling grids / Available in Anthracite, Black, Cloud Blue, Leaf Green, Marble, Lime, Sage Green, Serenity Blue or Slate Grey



**MUTE VERTICAL** WHILE DIVIDING SPACES, THIS ACOUSTIC PARTITION DOES NOT ENTIRELY BLOCK THE VIEW. INSTEAD, IT CREATES A SOCIABLE VISUAL BARRIER WITH FLOATING RECTANGULAR SOUND ABSORBING PANELS.

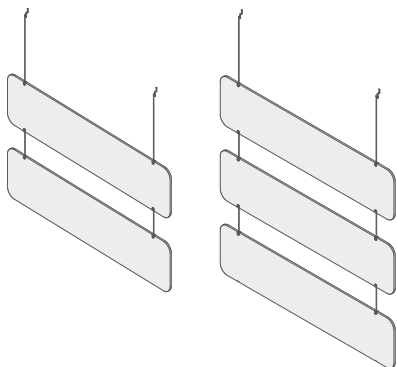

## MUTE VERTICAL

**2-TIER**  
MSV1232 + [COLOUR] - 1200 (W) x 750 (H) x 9mm

**3-TIER**  
MSV1233 + [COLOUR] - 1200 (W) x 1200 (H) x 9mm

9mm 100% Recyclable polyester panel / Each panel sits 150mm apart /  
3mm Solid ceiling connector - 400mm / 3mm solid linking rods - 150mm /  
Available in Anthracite, Black, Cloud Blue, Leaf Green, Marble, Lime, Sage Green, Serenity Blue or Slate Grey

\*Panel size 1200 x 297mm

### 100% POLYESTER COLOURS

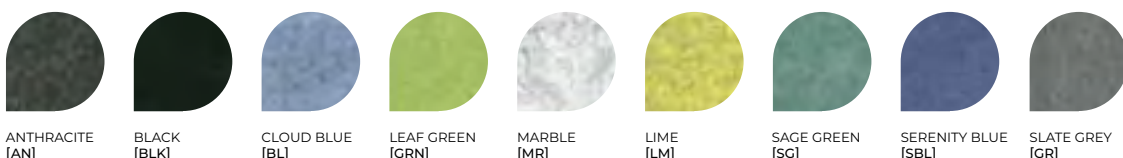

100% Polyester is extremely durable and requires little attention to maintain. Light dusting on a regular basis will prevent dust build up. Most marks can be cleaned with a mild detergent solution, followed by rinsing and blotting.

100%  
EXCLUSIVE

## MUTE BUZZ BOX

### MBB642M + [COLOUR]

642 (W) x 550 (D) x 1000 (H)

2 x 9mm 100% recyclable polyester panels with 3mm MDF support panel to middle / Anthracite 25mm thick laminate shelf / Attaches to wall with a cleat / Inside polyester panels in Marble / Outer panels in Anthracite, Black, Cloud Blue, Leaf Green, Lime, Sage Green, Serenity Blue or Slate Grey



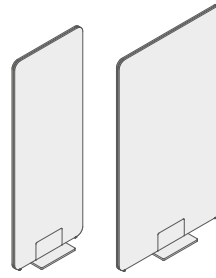

### MUTE BOUNDARY SCREEN

**MBS6016 + [COLOUR]** - 600 (W) x 1600 (H)

**MBS9016 + [COLOUR]** - 900 (W) x 1600 (H)

24mm Thick / 2 x 9mm 100% recyclable polyester panels with 6mm MDF support panel to middle / Available in Anthracite, Black, Cloud Blue, Leaf Green, Marble, Lime, Sage Green, Serenity Blue or Slate Grey

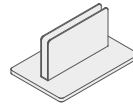

**MUTE BOUNDARY SCREEN CLAMP FOOT**  
Each / Black solid core base with U-Clamp

**MBSCLAMP**

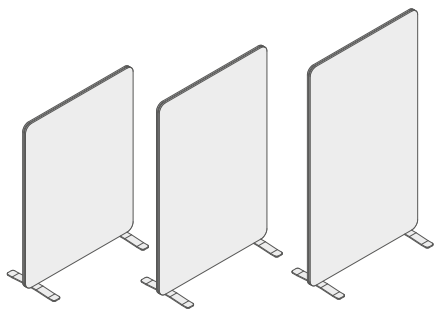

### MUTE MIRA BOUNDARY SCREEN

**MMS9012 + [COLOUR]** - 900 (W) x 1200 (H)

**MMS9014 + [COLOUR]** - 900 (W) x 1400 (H)

**MMS9016 + [COLOUR]** - 900 (W) x 1600 (H)

24mm Thick / 2 x 9mm 100% recyclable polyester panels with 6mm MDF support panel to middle / Available in Anthracite, Black, Cloud Blue, Leaf Green, Marble, Lime, Sage Green, Serenity Blue or Slate Grey

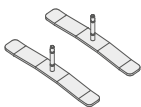

**MIRA BOUNDARY SCREEN STABILISING FEET**  
Set of two / Available in Black [BLK] & White [WH]

**MSB04 + [BLK/WH]**

#### 100% POLYESTER COLOURS

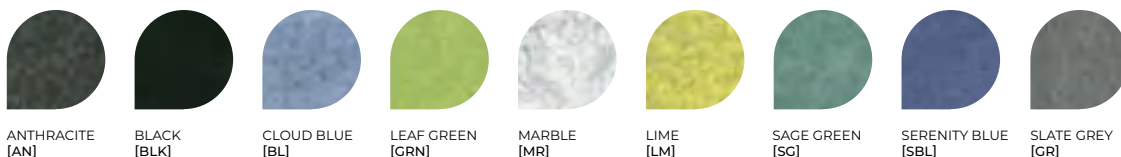

ANTHRACITE  
[AN]

BLACK  
[BLK]

CLOUD BLUE  
[BL]

LEAF GREEN  
[GRN]

MARBLE  
[MR]

LIME  
[LM]

SAGE GREEN  
[SG]

SERENITY BLUE  
[SBL]

SLATE GREY  
[GR]

100% Polyester is extremely durable and requires little attention to maintain. Light dusting on a regular basis will prevent dust build up. Most marks can be cleaned with a mild detergent solution, followed by rinsing and blotting.



### TIKI BOX STAND-IN PHONE BOOTH

**TKBF8622 + [FABRIC]**  
868 (W) x 836 (D) x 2200 (H)

32mm Aluminium profiled frame in black painted finish / Fabric to outside panels / Imported 4AKUSTIK, sound-absorbent system in MDF with a Natural Oak finish / Available in Vulcan fabric or COM

\*Fabric requirements : 7m upholstery

FABRICS



VULCAN FABRICS  
[V]  
Vulcan fabric colour to be  
specified on order



CUSTOMERS OWN MATERIAL  
[COM]



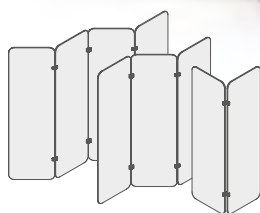

## MUTE ZIG-ZAG BOUNDARY SCREENS

**2 PANEL**  
**MXBS8012 + [COLOUR]**  
 800 (W) x 1200 (H)  
**MXBS8014 + [COLOUR]**  
 800 (W) x 1400 (H)  
**MXBS8016 + [COLOUR]**  
 800 (W) x 1600 (H)

**3 PANEL**  
**MXBS1212 + [COLOUR]**  
 1200 (W) x 1200 (H)  
**MXBS1214 + [COLOUR]**  
 1200 (W) x 1400 (H)  
**MXBS1216 + [COLOUR]**  
 1200 (W) x 1600 (H)

**4 PANEL**  
**MXBS1612 + [COLOUR]**  
 1600 (W) x 1200 (H)  
**MXBS1614 + [COLOUR]**  
 1600 (W) x 1400 (H)  
**MXBS1616 + [COLOUR]**  
 1600 (W) x 1600 (H)

9mm 100% Recyclable polyester panels with plastic hinges / Available in Anthracite, Black, Cloud Blue, Leaf Green, Marble, Lime, Sage Green, Serenity Blue or Slate Grey

### 100% POLYESTER COLOURS

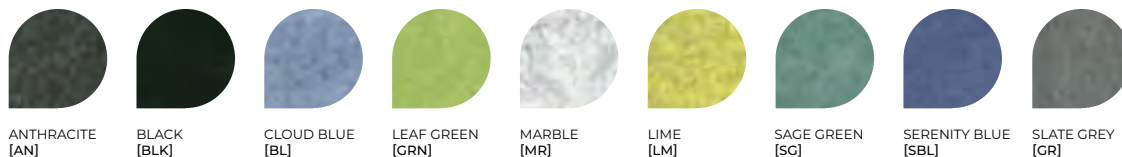

ANTHRACITE  
[AN]

BLACK  
[BLK]

CLOUD BLUE  
[BL]

LEAF GREEN  
[GRN]

MARBLE  
[MR]

LIME  
[LM]

SAGE GREEN  
[SG]

SERENITY BLUE  
[SBL]

SLATE GREY  
[GR]

100% Polyester is extremely durable and requires little attention to maintain. Light dusting on a regular basis will prevent dust build up. Most marks can be cleaned with a mild detergent solution, followed by rinsing and blotting.





# RECEPTION



**WELCOME** RECEPTION WITH ITS WATERFALL COUNTER, EPITOMISES A MODERN MODULAR CONCEPT THAT IS FUNCTIONAL AND FLEXIBLE.



## WELCOME RECEPTION

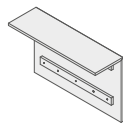

**RECEPTION WATERFALL**  
**WC1100 + [FINISH]**  
1100 (W) x 350 (D) x 700 (H)

25mm Laminate construction / Waterfall can be positioned either, left, right or centre to counter / Available in CN Exclusive laminates, Anthracite, Stone Grey or White

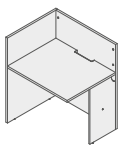

Left hand side

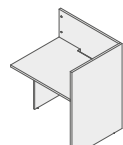

Right hand side

**RECEPTION END MODULE**  
**WC901 + L/R + [FINISH]**  
900 (W) x 736 (D) x 1089 (H)

25mm Laminate construction / Left or right handed / Available in CN Exclusive laminates, Anthracite, Stone Grey or White

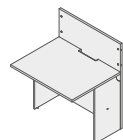

**RECEPTION MIDDLE MODULE**  
**WC900 + [FINISH]**  
900 (W) x 736 (D) x 1089 (H)

25mm Laminate construction / Available in CN Exclusive laminates, Anthracite, Stone Grey or White

### LAMINATE FINISHES



ACACIA  
[AC]



DARK EUCALYPTUS  
[DE]



NATURAL WALNUT  
[NW]



TAORMINA ASH  
[TA]



TRUE OAK  
[TO]



ANTHRACITE  
[AN]



STONE GREY  
[SG]



WHITE  
[WH]



**SALUTE**, THE SMOOTH APPEARANCE OF THIS PRESTIGIOUS RECEPTION COUNTER IS ACCENTUATED BY ITS BALANCE OF FORM AND FUNCTION.

LAMINATE FINISHES

-  ACACIA [ACW]
-  DARK EUCALYPTUS [DEW]
-  NATURAL WALNUT [NWW]
-  TAORMINA ASH [TAW]
-  TRUE OAK [TOW]
-  WHITE [WH]

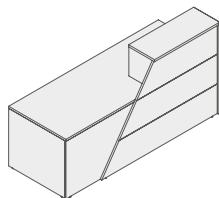

Left hand side shown

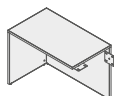

Left hand side shown

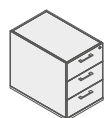

**SALUTE** RECEPTION

**SAL2100 + [L/R] + [FINISH]**

2100 (L) x 800 (W) x 1100 (H)

**SAL2400+ [L/R] + [FINISH]**

2400 (L) x 800 (W) x 1100 (H)

25mm Laminate construction / White desk component with angled front panel & counter top in wood grain finish / Left or right handed / Available in CN Exclusive laminates paired with White

**EXTENSION**

**SAL1000 + [L/R] + [WH]**

1000 (L) x 600 (W) x 725 (H)

25mm Laminate construction with 16mm full modesty panel / Left or right handed / Available in White laminate

**DESK HEIGHT PEDESTAL**

**SAL703 + [FINISH]**

496 (W) x 550 (D) x 691 (H)

3 x Standard drawers with floating pen & pencil tray / Available in CN Exclusive laminates & White

Images shown for display purposes only. Actual finishes may vary.



**FRANKLIN**, ITS STARK MODERN LINES ACCENTUATED BY THE ILLUMINATED TOP COUNTER, MAKES ITS FIRST IMPRESSION A LASTING ONE.

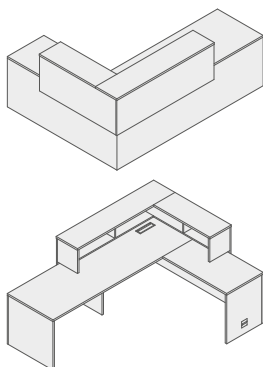

### FRANKLIN RECEPTION

**FK2118 + [L/R] + [FINISH]**  
2100 (L) x 1800 (D) x 1080 (H)

**FK2418 + [L/R] + [FINISH]**  
2400 (L) x 1800 (D) x 1080 (H)

**FK2718 + [L/R] + [FINISH]**  
2700 (L) x 1800 (D) x 1080 (H)

25mm Laminate construction with 16mm counter & modesty panel / Includes LED undercounter strip lights with 2 pin supply cable / Available in CN Exclusive laminates & White or CN Exclusive laminates paired with anthracite, black, stone grey or white

**\*When pairing, desk will be in wood grain finish with counter top in anthracite, black, stone grey or white**

#### LAMINATE FINISHES

  
ACACIA  
[AC] / [ACA] / [ACS] / [ACW]

  
DARK EUCALYPTUS  
[DE] / [DEA] / [DEB] / [DEW]

  
NATURAL WALNUT  
[NW] / [NWA] / [NWB] / [NWW]

  
TAORMINA ASH  
[TA] / [TAA] / [TAS] / [TAW]

  
TRUE OAK  
[TO] / [TOA] / [TOB]

  
WHITE  
[WH]

Right hand side shown



**ECOCENTRIC GRID**, FIRST IMPRESSIONS COUNT. THAT'S WHY IT IS IMPORTANT TO MAKE A STATEMENT WITH YOUR RECEPTION COUNTER.

### ECOCENTRIC GRID RECEPTION

#### LAMINATE FINISHES

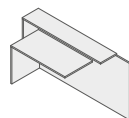
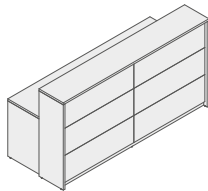

\*Left hand side shown

**ECOG1800 + [FINISH]**  
1800 (L) x 825 (W) x 1100 (H)

**ECOG2100 + [FINISH]**  
2100 (L) x 825 (W) x 1100 (H)

**ECOG2700 + [FINISH]**  
2700 (L) x 825 (W) x 1100 (H)

25mm Laminate construction with 16mm front panels edged in anthracite, black, stone grey or white PVC edging / Non-handed / Available in CN Exclusive laminates & White paired with anthracite, black, stone grey or white

#### EXTENSION

**ECO200L + [FINISH]** - Left hand side

**ECO200R + [FINISH]\*** - Right hand side

2000 (L) x 650 (W) x 1100 (H)

Not Shown\*

25mm Laminate construction / Left or right handed / Available in CN Exclusive laminates & White paired with anthracite, black, stone grey or white

\*When pairing, desk & front panels will be in wood grain or white finish with counter top, sides & base in paired colour: anthracite, black, stone grey or white







**XPRESS-TEC**, THIS RECEPTION COUNTER ATTRACTS ATTENTION WITH ITS SIGNATURE FEATURE PANEL AND DISTINCTIVE SOLID COLOUR SLATS.

### XPRESS-TEC RECEPTION

#### LAMINATE FINISHES

- 

ACACIA  
[AC] / [ACA] / [ACS] / [ACW]
- 

DARK EUCALYPTUS  
[DE] / [DEA] / [DEB] / [DEW]
- 

NATURAL WALNUT  
[NW] / [NWA] / [NWB] / [NWW]
- 

TAORMINA ASH  
[TA] / [TAA] / [TAS] / [TAW]
- 

TRUE OAK  
[TO] / [TOA] / [TOB]
- 

WHITE  
[WH] / [WHA] / [WHB]

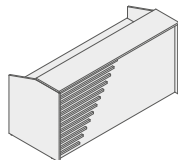

**SIDE SLAT DETAIL**  
**XPTR1800 + [FINISH]**  
 1800 (L) x 827 (W) x 1084 (H)  
**XPTR2100 + [FINISH]**  
 2100 (L) x 827 (W) x 1084 (H)  
**XPTR2400 + [FINISH]**  
 2400 (L) x 827 (W) x 1084 (H)

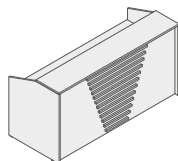

**"V" SLAT DETAIL**  
**XPTRV1800 + [FINISH]**  
 1800 (L) x 827 (W) x 1084 (H)  
**XPTRV2100 + [FINISH]**  
 2100 (L) x 827 (W) x 1084 (H)  
**XPTRV2400 + [FINISH]**  
 2400 (L) x 827 (W) x 1084 (H)

25mm Laminate construction / Recessed front panel with 25 x 25mm slat detail / Non-handed / Available in a choice of CN Exclusive laminates & White paired with slats in anthracite, black, stone grey or white

### XPRESS-TEC RECEPTION EXTENSION

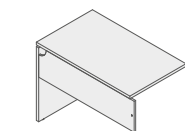

Right hand side shown

**XPTR1000L + [FINISH]\*** - Left hand side  
**XPTR1000R + [FINISH]** - Right hand side  
 1000 (L) x 600 (W) x 725 (H)  
 Not Shown\*

25mm Laminate construction / Left or right handed / Available in a choice of CN Exclusive laminates & White

\*When pairing, counter will be in wood grain or white finish with slats in paired colour: anthracite, black, stone grey or white





100%  
EXCLUSIVE

**COVE POD**, THESE MEETING PODS ARE IDEAL FOR OPEN OFFICE AREAS WHERE YOU CAN CREATE A QUIET AND PRIVATE SPACE FOR WORKING OR A STAND ALONE MEETING AREA AWAY FROM OFFICE DISTRACTIONS.

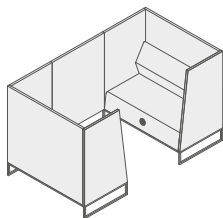

#### COVE POD BOOTH

CVP2514 + [BLK] + [COM]  
CVP2514P + [BLK] + [COM] - Powered Up\*  
2510 (W) x 1400 (D) x 1420 (H)

2 x Double seater booths on black metal frame /  
Black mesh front privacy panels / Includes centre  
panel / Upholstered in [COM]

\*Fabric requirements : 24,2m upholstery  
(5,4m fixed seat & back) / (4m loose back cushion) /  
(12,6m privacy back & side panels) / (2,2m  
centre panel)

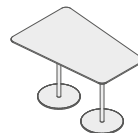

#### COVE POD TABLE

CVP1286 + [BLK/WH]  
1200 (L) x 800 - 600 (W) x 750 (H)

12mm Thick solid core top / 2 x black metal  
pole legs with 400 Ø black solid core disc  
base / Available in Black [BLK] or White [WH]

#### \*POWERED UP:

- Excludes DOT EVO and 3m supply cables - **must be ordered separately**

2 x DET1N + [BLK] - DOT EVO  
2 x SC30N - Supply Cable





**CO-ACT**, A SIMPLE YET VERSATILE PIECE WITH ENDLESS POSSIBILITIES THAT CAN BE POSITIONED SIDE-BY-SIDE OR BACK-TO-BACK.

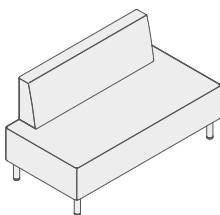

### **CO-ACT**

**CA1381 + [COM]**  
1300 (L) x 660 (W) x 745 (H)

Ottoman with fixed back on black round steel legs / Available in [COM]

\*Fabric requirements : 3,5m upholstery  
(2m seat / 1,5m back)



Images shown for display purposes only. Actual finishes may vary.



**STRAIGHT-UP** LOUNGE SYSTEM ADAPTS TO CHANGING WORK STYLES AND SHIFTING WORK POSTURES, CREATING A “THIRD PLACE” ANYWHERE WHILE OFFERING VARYING DEGREES OF PRIVACY.

### **STRAIGHT-UP** LOUNGE SYSTEM

**SINGLE SEATER**  
**SU01 + [FINISH] + [COM]**  
 800 (L) x 800 (W) x 775 (H)

\*Fabric requirements : 4,5m upholstery  
 (3,8m inside panels & seat cushion / 1m loose back cushion)

**OTTOMAN**  
**SU800 + [FINISH] + [COM]**  
 800 (L) x 800 (W) x 470 (H)

\*Fabric requirements : 2m upholstery

**DOUBLE SEATER**  
**SU02 + [FINISH] + [COM]**  
 1300 (L) x 800 (W) x 775 (H)

\*Fabric requirements : 8m upholstery  
 (6m inside panels & seat cushion / 2m loose back cushions)

**TRIPLE SEATER**  
**SU03 + [FINISH] + [COM]**  
 1850 (L) x 800 (W) x 775 (H)

\*Fabric requirements : 10m upholstery  
 (7m inside panels & seat cushion / 3m loose back cushions)

20mm Square tube steel frame in black painted finish / Outside panels in 16mm laminate / Inner panels in ultra-high density polyurethane foam / Webbed platform supports high-density foam seat / Loose back cushions with firm support / Available in CN Exclusive laminates & Anthracite with upholstery in Customers Own Material [COM]



LAMINATE FINISHES



ACACIA  
[AC]



DARK EUCALYPTUS  
[DE]



NATURAL WALNUT  
[NW]



TAORMINA ASH  
[TA]



TRUE OAK  
[TO]



ANTHRACITE  
[AN]

## STRAIGHT-UP BOOTH

**SINGLE BOOTH**  
**SUB01 + [FINISH] + [COM]**  
800 (L) x 800 (W) x 1350 (H)

**\*Fabric requirements : 7m upholstery**  
**(6m inside panels & seat cushion / 1m loose back cushions)**

**DOUBLE BOOTH**  
**SUB02 + [FINISH] + [COM]**  
1300 (L) x 800 (W) x 1350 (H)

**\*Fabric requirements : 10,1m upholstery**  
**(8,1m inside panels & seat cushion / 2m loose back cushions)**

20mm Square tube steel frame in black painted finish / Outside panels in 16mm laminate / Inner panels in ultra-high density polyurethane foam / Webbed platform supports high-density foam seat / Loose back cushions with firm support / Available in CN Exclusive laminates & Anthracite with upholstery in Customers Own Material [COM]

100%  
EXCLUSIVE



## KYLE BOOTH

SINGLE SEATER  
KYB01BLK + [FABRIC]  
KYB01PBLK + [FABRIC] - Powered Up\*  
800 (W) x 737 (D) x 1350 (H)

\*Fabric requirements : 11m upholstery  
(3m seat & loose back cushion) (8m base, side & back panels)

Fully upholstered booth with loose seat & back cushions / When two-tone upholstery specified, the piping on the loose back cushion will be in the contrasting fabric / Black metal frame / Available in Vulcan fabric or COM

DOUBLE SEATER  
KYB02BLK + [FABRIC]  
KYB02PBLK + [FABRIC] - Powered Up\*  
1300 (W) x 737 (D) x 1350 (H)

\*Fabric requirements : 12m upholstery  
(4m seat & loose back cushion) (8m base, side & back panels)

### \*POWERED UP:

- Includes MICRODOT with 1 x USB charging port, including 3m supply cable

FABRICS



VULCAN FABRICS  
[V]  
Vulcan fabric colour to be  
specified on order



CUSTOMERS OWN MATERIAL  
[COM]



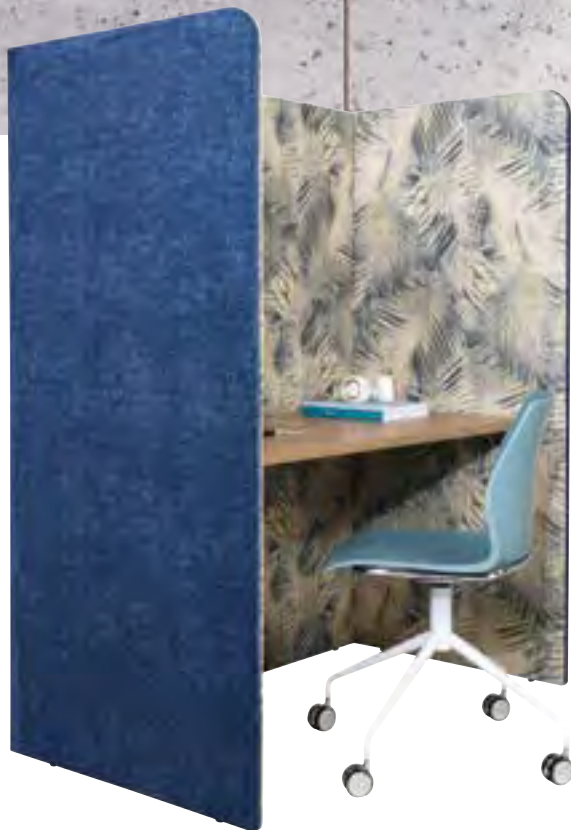

## KYLE FOCUS DESK

**KYFD1216 + [FINISH] + [FABRIC]**  
1270 (W) x 737 (D) x 1600 (H)

Fully upholstered side & back panels with fabric beading / Single cable access below desk top / Available in Vulcan fabric or COM / 25mm Rectangular top with power gap / Available in CN Exclusive laminates, Anthracite, Stone Grey or White

**\*Fabric requirements : 11m upholstery  
(5,5m inside panels / 5,5m outside panels)**

### FABRICS



**VULCAN FABRICS  
[V]**

Vulcan fabric colour to be specified on order



**CUSTOMERS OWN MATERIAL  
[COM]**

### LAMINATE FINISHES



**ACACIA  
[AC]**



**DARK EUCALYPTUS  
[DE]**



**NATURAL WALNUT  
[NW]**



**TAORMINA ASH  
[TA]**



**TRUE OAK  
[TO]**



**ANTHRACITE  
[AN]**



**STONE GREY  
[SG]**



**WHITE  
[WH]**



**AMOEBA**, AN INFORMAL HIGH OR LOW TABLE WITH AN ORGANICALLY SHAPED TOP ENCOURAGING ACTIVE ENGAGEMENT.



SUPALAM FINISHES



ACACIA  
[AC]



DARK EUCALYPTUS  
[DE]



NATURAL WALNUT  
[NW]



TAORMINA ASH  
[TA]



TRUE OAK  
[TO]



ANTHRACITE  
[AN]



WHITE  
[WH]

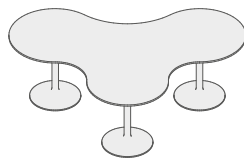

Happy Hour base 690 (H)



Pepe base 720 (H)

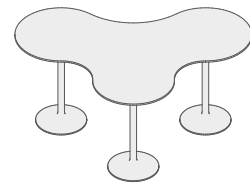

Happy Hour base 1000 (H)

**AMOEBA MEETING TABLE**

**TABLE TOP**

**AMT2316 + [FINISH]**

2315 (L) x 1630 (W) x 22mm

22mm Supalam top with reverse chamfered edge / Available with Happy Hour base or Pepe base / Available in a choice of CN Exclusive Supalam finishes & White

**PEPE TABLE BASE**

**PP720 + [AN/WH]** - 500 Ø x 720 (H)

Pepe base, available in Anthracite [AN] & White [WH]

**HAPPY HOUR TABLE BASE**

**HH01 + [BLK/CH/WH]** - 500 Ø x 690 (H)

**HH03 + [BLK/CH/WH]** - 500 Ø x 1000 (H)

Happy Hour base, available in Black [BLK], Chrome [CH] or White [WH]

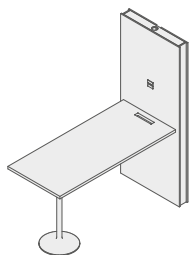

## MEDIA ISLAND

### TOP

**MEDIAT2090 + [FINISH]**

**MEDIATR2090 + [FINISH]** - Including cut-out for BLADE 2 power set  
2000 (L) x 900 (W) x 25mm\*

25mm Top available with or without cut-out for BLADE 2 power set / Available in CN Exclusive Laminates, Anthracite, Stone Grey & White

\*Fits BLADE 2 power set



**BL2EV22N + [BLK/SI]** - Blade EVO



**BL2EC22N + [BLK/SI]** - Blade ECO  
(Must be ordered separately)

### WALL

**MEDIAW2010 + [FINISH]**

1000 (W) x 150 (D) x 2000 (H)

Vertical wall including 2 x cable outlets to front / Available in CN Exclusive Laminates, Anthracite, Stone Grey & White

### BASE

**HH03 + [BLK/CH/WH]**

500 Ø x 1000 (H)

Happy Hour base, available in Black [BLK], Chrome [CH] or White [WH]

### LAMINATE FINISHES



ACACIA  
[AC]



DARK EUCALYPTUS  
[DE]



NATURAL WALNUT  
[NW]



TAORMINA ASH  
[TA]



TRUE OAK  
[TO]



ANTHRACITE  
[AN]



STONE GREY  
[SG]



WHITE  
[WH]





# SOFT SEATING



**TOBI** IS INSPIRED BY THE SMOOTH 'TOBI-ISHI' STONES FROM WHICH IT TAKES ITS NAME AND, LIKE THEM, IT SEEMS TO FLOAT, SUPPORTED BY FOUR SOLID WOOD LEGS.



SrtLand®

The **TOBI** is a **SPECIAL IMPORT**. Enquire about stock & import lead times.



Images shown for display purposes only. Actual finishes may vary.

**BOMM** MODULES COMBINE EASILY CREATING MANY DIFFERENT CONFIGURATIONS SUITABLE FOR LOUNGE OR WORKING AREAS AS WELL AS INFORMAL OUTDOOR MEETINGS.



SitLand®



The BOMM is a SPECIAL IMPORT. Enquire about stock & import lead times.

Images shown for display purposes only. Actual finishes may vary.





**DROP** IS A MODULAR SYSTEM BUILT AROUND THREE ELEMENTS: THE BACKREST, ARMREST AND SEAT. LIKE DIGITAL DRAG-AND-DROP SYSTEMS, IT IS DESIGNED TO BE SIMPLE AND EASY TO PUT TOGETHER IN ANY CONFIGURATION.



SitLand



The **DROP** is a **SPECIAL IMPORT**. Enquire about stock & import lead times.

Images shown for display purposes only. Actual finishes may vary.



**MILOS LOUNGE** FEATURES A GENEROUS SEAT ENHANCED BY A DOUBLE PADDED COVER FOR EXTREME COMFORT. OPTIONAL ARMRESTS AND DIFFERENT BASE OPTIONS: WOOD, 4-LEGGED AND 4-STAR, MAKES IT PERFECT FOR LOUNGE AREAS.



SittLand®

The MILOS LOUNGE is a SPECIAL IMPORT. Enquire about stock & import lead times.





**LIDO** IS A MODULAR SYSTEM OF POUFS DESIGNED FOR CUSTOMISING THE WAITING SPACE. SIMPLE AND BASIC FORMS ALLOW MODULARITY AND INFINITE CUSTOMISATION.



SitLand®



The LIDO is a **SPECIAL IMPORT**. Enquire about stock & import lead times.

Images shown for display purposes only. Actual finishes may vary.



**GRANDEUR**, A COMBINATION OF COMFORT AND SIMPLICITY SUPPORTED WITH MODERN ELEMENTS. SUPERB MATERIALS AND EXQUISITE CRAFTSMANSHIP ADD A TOUCH OF HIGH END ELEGANCE TO THE DESIGN.

FABRICS



BLUE 21  
[BL]



GREY 35  
[GR]



YELLOW 99  
[YL]



**GRANDEUR SINGLE SEATER**

**GDU01 + [FABRIC]**  
870 (W) x 720 (D) x 750 (H)

Seat & back in high density moulded foam /  
Round tube leg in black painted finish /  
Standard blue, grey or yellow upholstery



**GRANDEUR DOUBLE SEATER**

**GDU02 + [FABRIC]**  
1500 (W) x 720 (D) x 750 (H)

Seat & back in high density moulded foam /  
Round tube leg in black painted finish /  
Standard blue, grey or yellow upholstery



**GRANDEUR TRIPLE SEATER**

**GDU03GR**  
2160 (W) x 720 (D) x 750 (H)

Seat & back in high density moulded foam / Round tube leg in black painted finish / Standard grey upholstery



**BREEZE** STYLE IS EXTREMELY SIMPLE AND ELEGANT WITH A SOFT MOULDED FOAM SEAT AND CURVED BACK WITH INTEGRAL BOLSTER CUSHIONS SUPPORTED BY A STEEL FRAME.



**BREEZE** SINGLE SEATER

**BRZ01 + [FABRIC]**  
740 (L) x 770 (D) x 780 (H)

Seat, back & cushion in moulded foam / Steel round tube frame in black painted finish / Available in Standard coral or pickle green fabric upholstery

FABRICS



CORAL 66  
[CR]



PICKLE GREEN 158  
[GRN]



**BREEZE** TRIPLE SEATER

**BRZ03GR**  
1960 (W) x 770 (D) x 780 (H)

Seat, back & cushions in moulded foam / Steel round tube frame in black painted finish / Available in Standard grey fabric upholstery

FABRIC



GREY 35  
[GR]

**INC NO.45** MAXIMUM COMFORT AND STYLE WITH A SCULPTURED LIGHT SEAT RESTING ON AN ELEGANT STEEL BASE.



**INC No.45 CHAIR**

**INC45 + [FABRIC]**  
720 (W) x 650 (D) x 780 (H)

\*Fabric requirements : 1,5m upholstery

Tub chair with steel cross loop base in black painted finish / Scandi naval blue, graphite or seafoam green upholstery or [COM]

FABRICS



NAVAL BLUE  
[BL]



GRAPHITE  
[GRP]



SEAFOAM GREEN  
[SF]



CUSTOMERS OWN  
MATERIAL  
[COM]





**MILAN METAL**, MODERN, COMFORTABLE AND FUNCTIONAL. A TOUCH OF ELEGANCE AT AN AFFORDABLE PRICE POINT.



### MILAN METAL TUB CHAIR

**MLM01 + [B/W] + [FABRIC]**

710 (W) x 610 (D) x 770 (H)

Tub chair with steel cross loop base in Black [B] or White [W] painted finish / Upholstered in Tweed Anthracite or [COM]

\*Fabric requirement: 2m upholstery (Inside back: 1m / Outside back: 1m / Seat: 1m)

FABRIC



TWEED ANTHRACITE  
[AN]



CUSTOMERS OWN  
MATERIAL  
[COM]

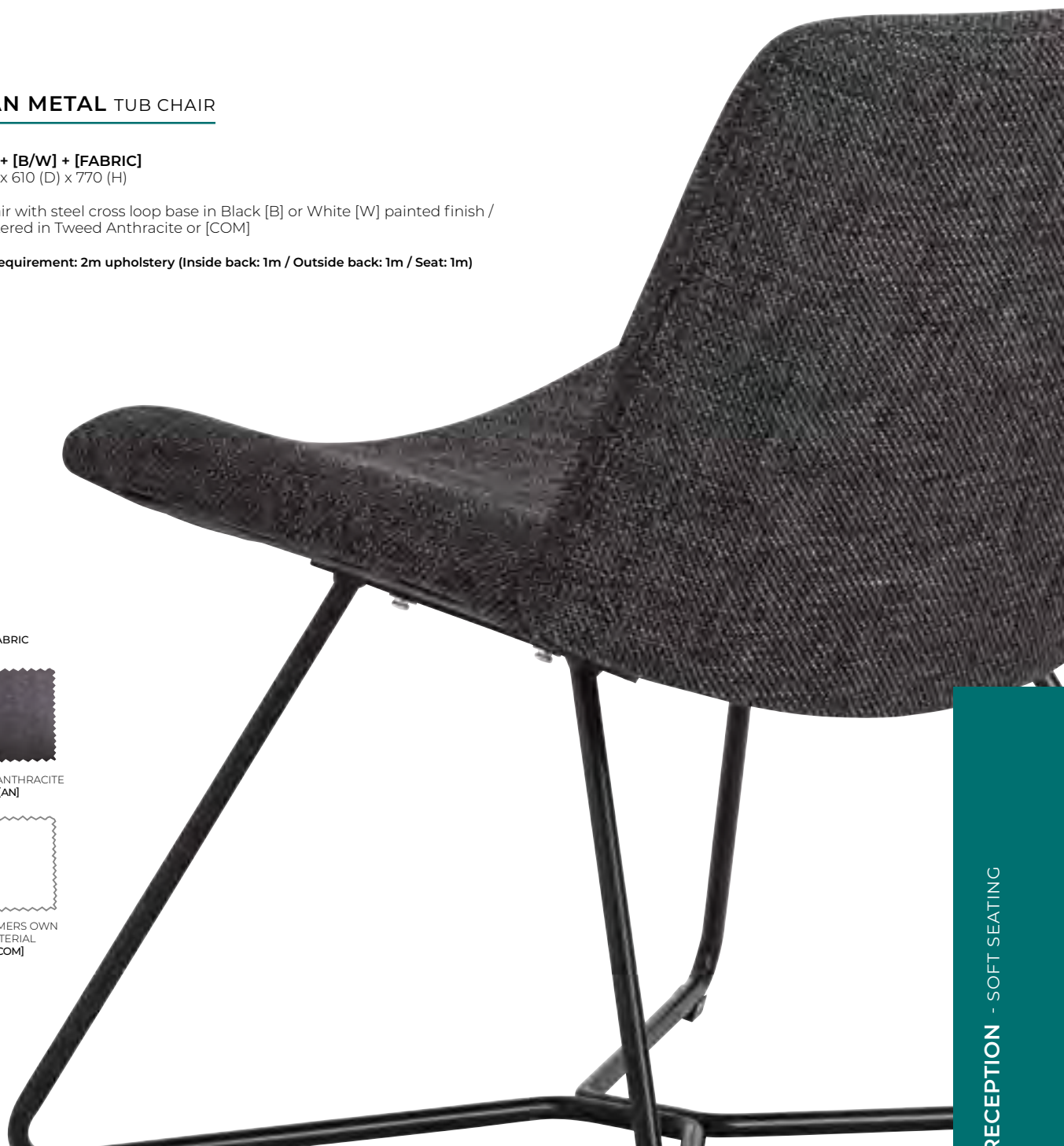



100%  
EXCLUSIVE



### SOUL TUB CHAIR

**SLO1 + [FABRIC]**  
840 (W) x 850 (D) x 850 (H) x 400 (SH)

Moulded shell reinforced with inner steel frame / Tubular steel base in black painted finish / Standard grey or yellow upholstery

FABRICS



GREY 32  
[GR]



YELLOW 99  
[YL]

100%  
EXCLUSIVE



### SOCIAL TUB CHAIR

**SCO1 + [FABRIC]**  
780 (W) x 670 (D) x 830 (H) x 420 (SH)

Moulded shell reinforced with inner steel frame / Solid Ash wood base in natural finish / Standard grey or teal upholstery

FABRICS



GREY 32  
[GR]



TEAL 93  
[TL]



## LIBERTY

DOUBLE SEATER  
LT02COM  
2100 (W) x 800 (D) x 750 (H)

Loose back & seat cushions / Steel frame in black painted finish / Upholstered in [COM]

\*Fabric requirements : 12,5m upholstery



## LIBRARY

SINGLE SEATER  
LB01COM  
800 (W) x 800 (D) x 880 (H)

Fixed back with loose seat cushion / Steel frame in black painted finish / Upholstered in [COM]

\*Fabric requirements : 5m upholstery



## LOOP

SINGLE SEATER  
LOOP01COM  
685 (W) x 750 (D) x 700 (H)

Fixed seat & back / Steel frame in black painted finish / Upholstered in [COM]

\*Fabric requirements : 4m upholstery



## HILTON

**TRIPLE SEATER**  
**HT03 + [FABRIC]**  
 2175 (W) x 810 (D) x 760 (H)

\*Fabric requirements : 10,5m upholstery

**DOUBLE SEATER**  
**HT02 + [FABRIC]**  
 1520 (W) x 810 (D) x 760 (H)

\*Fabric requirements : 6,3m upholstery

**SINGLE SEATER**  
**HT01 + [FABRIC]**  
 810 (W) x 810 (D) x 760 (H)

\*Fabric requirements : 4,7m upholstery

Loose back & seat cushions / Steel frame in black painted finish / Upholstered in Sequel Peppercorn fabric or [COM]

FABRIC



SEQUEL PEPPERCORN  
[PC]



CUSTOMERS OWN  
MATERIAL  
[COM]



FABRIC



TWEED ANTHRACITE  
[AN]



CUSTOMERS OWN  
MATERIAL  
[COM]

## DAPPER

**DOUBLE SEATER**  
**DPP02 + [FABRIC]**  
 1620 (W) x 800 (D) x 720 (H)

\*Fabric requirements : 8m upholstery

**SINGLE SEATER**  
**DPP01 + [FABRIC]**  
 720 (W) x 800 (D) x 720 (H)

\*Fabric requirements : 5m upholstery

Loose back & seat cushions / Steel frame in black painted finish / Upholstered in Tweed Anthracite or [COM]

Images shown for display purposes only. Actual finishes may vary.



## GLAM

**DOUBLE SEATER**  
**GLM02B + [FABRIC]** - Black legs  
**GLM02 + [FABRIC]** - Natural legs  
 1830 (W) x 850 (D) x 780 (H)

\*Fabric requirements : 12m upholstery

Fixed seat & back with button detail / Solid ash wood legs in natural or black stain / Upholstered in Tweed Anthracite fabric or [COM]

**SINGLE SEATER**  
**GLM01B + [FABRIC]** - Black legs  
**GLM01 + [FABRIC]** - Natural legs  
 900 (W) x 850 (D) x 780 (H)

\*Fabric requirements : 5m upholstery

FABRIC



TWEED ANTHRACITE  
[AN]



CUSTOMERS OWN  
MATERIAL  
[COM]

**MOOD**, WITH MODERN LINES AND CLASSIC CURVES, THIS TUB CHAIR SITS WELL IN ANY SPACE.



FABRIC



TWEED ANTHRACITE  
[AN]



CUSTOMERS OWN  
MATERIAL  
[COM]

## MOOD

**MD01 + [FABRIC]**  
 700 (W) x 700 (D) x 700 (H)

Tub chair with solid ash wood legs /  
 Upholstered in Tweed Anthracite fabric or [COM]

\*Fabric requirements : 4,5m upholstery (3,8m back / 0,8m seat)

**CARLTON**, WITH A VINTAGE-STYLE SILHOUETTE, SLOPING ARM AND FIXED SEAT & BACK, SET ON A SOLID ASH WOOD PLATFORM WITH TAPERED LEGS IN NATURAL OR BLACK STAIN.



## **CARLTON**

DOUBLE SEATER  
**CR02BCOM** - Black legs  
**CR02COM** - Natural legs  
1650 (W) x 800 (D) x 900 (H)

\*Fabric requirements : 9m upholstery

SINGLE SEATER  
**CR01BCOM** - Black legs  
**CR01COM** - Natural legs  
700 (W) x 800 (D) x 900 (H)

\*Fabric requirements : 6m upholstery

Fitted seat & back / Solid ash wood wood frame with tapered legs in natural or black stain / Upholstered in [COM]

**SCANDI**, FEATURING A MID-CENTURY MODERN STYLE WITH BUTTON DETAILING. A TRUE STATEMENT PIECE.



## **SCANDI**

DOUBLE SEATER  
**SC02BCOM** - Black legs  
**SC02COM** - Natural legs  
1740 (W) x 800 (D) x 800 (H)

\*Fabric requirements : 8,5m upholstery

SINGLE SEATER  
**SC01BCOM** - Black legs  
**SC01COM** - Natural legs  
840 (W) x 800 (D) x 800 (H)

\*Fabric requirements : 5,5m upholstery

Fixed seat & back with button detail / Solid ash wood legs in natural or black stain / Upholstered in [COM]



100%  
EXCLUSIVE

**CUBE**, LIFE ITSELF REQUIRES A SENSE OF RITUAL ELEMENT LIKE THE OFFICE WORKSPACE NEEDING A CUBE CHAIR.



FABRICS



CORAL 66  
[CR]



PICKLE GREEN 158  
[GRN]



DENIM BLUE  
[BL]

### **CUBE** TUB CHAIR

**CUBE01 + [FABRIC]**  
850 (W) x 700 (D) x 720 (H)

Molded shell reinforced with inner steel frame /  
Standard coral, pickle green or denim blue fabric upholstery





**LOBBY**, IS A SMALL MULTI-PURPOSE TUB THAT SITS WELL AT ANY BOARDROOM OR MEETING TABLE AS WELL AS ON ITS OWN. AVAILABLE IN A CHOICE OF THREE UNDERSTATED FABRIC OPTIONS.



FABRICS



DESERT SAND  
[DS]



DARK GREY  
[DGR]



LIGHT GREY  
[LGR]

### **LOBBY 4-STAR MEETING**

**LBV01 + [FABRIC]**

Moulded shell reinforced with inner steel frame / Swivel and gas height adjustment / 4-Star polished aluminium base / Standard desert sand, dark grey or light grey upholstery



### **JUAN ARMCHAIR**

**JN01COM**

600 (W) x 600 (D) x 840 (H)

Tub chair on 4-legged steel frame with tapered legs in black painted finish / Upholstered in [COM]

\*Fabric requirements : 2,8m upholstery



**LUTIE**, LESS IS MORE. SPACIOUS AND COMFORTABLE FLOATING ON A LIGHT SLEIGH BASE OR 4-STAR SWIVEL.



## LUTIE SLEIGH

### LT01 + [FABRIC]

750 (W) x 700 (D) x 770 (H)

Moulded shell reinforced with inner steel frame /  
Steel cross loop base in black painted finish /  
Standard blue, green or oatmeal upholstery



#### FABRICS



BLUE  
[BL]



GREEN  
[GRN]



OATMEAL  
[ML]

## LUTIE 4-STAR

### LT04 + [FABRIC]

750 (W) x 700 (D) x 770 (H)

Moulded shell reinforced with inner steel frame /  
4-Star black swivel base / Standard blue, green or  
oatmeal upholstery



**CHAT** IS A SMALL MULTIPURPOSE TUB CHAIR THAT SITS WELL AT ANY BOARDROOM OR MEETING TABLE, AS WELL AS ON ITS OWN.

FABRICS



GREY 32  
[GR]



GREEN 82  
[GRN]



ORANGE 148  
[OR]

**CHAT** ARMCHAIR

**CH01 + [FABRIC]**

620 (W) x 600 (D) x 750 (H) x 490 (SH)

Seat shell reinforced with 10mm steel frame / High density moulded foam / Solid Ash wood base in natural finish / Upholstered in standard grey, green & orange fabrics





100%  
EXCLUSIVE

**SADDLE OTTOMANS**, DECORATIVE AND FUNCTIONAL, THESE PLAYFUL PIECES ADD A LITTLE EXTRA SEATING & FUN TO ANY ROOM.



PIXEL CHARCOAL / BISON STEELBLUE  
[BL]



PIXEL STONE / BISON DAHLIA  
[OR]



PIXEL CRAYON / BISON SEAFOAM  
[SF]

PIXEL CHARCOAL / BISON EBONY  
[BLK]



CUSTOMERS OWN  
MATERIAL  
[COM]

## SADDLE OTTOMAN

SD520 + [FABRIC/COM]  
520 Ø x 460 (H)

Genuine leather holding strap / Upholstered in Pixel Charcoal paired with Bison Ebony [BLK] / Pixel Charcoal paired with Bison Bluesteel [BL] / Pixel Crayon paired with Bison Seafoam [SF] / Pixel Stone paired with Bison Dahlia [OR] or COM

\*Fabric requirements: 2m upholstery (Top: 1,7m / Bottom: 0,25m)



## TRENDY OTTOMAN

Upholstered in [COM]

**ROUND 500Ø**  
**TR500RCOM**  
 500 Ø x 450 (H)

\*Fabric requirements:  
 2,5m upholstery

**SQUARE 500**  
**TR500SCOM**  
 500 (W) x 500 (D) x 450 (H)

\*Fabric requirements:  
 2m upholstery

**TRIANGULAR**  
**TR600TCOM**  
 600 (W) x 600 (D) x 450 (H)

\*Fabric requirements:  
 2m upholstery

**ROUND 450Ø**  
**TR450RCOM**  
 450 Ø x 450 (H)

\*Fabric requirements:  
 2m upholstery

**SQUARE 450**  
**TR450SCOM**  
 450 (W) x 450 (D) x 450 (H)

\*Fabric requirements:  
 1,5m upholstery



## HOPSCOTCH OTTOMAN

**HOPS450COM**  
 450 Ø x 470 (H)

Fully upholstered with seamline to middle /  
 Upholstered in [COM]

\*Fabric requirements: 2m upholstery (Top: 1m / Bottom: 1m)









**RANCH**, IS INSPIRED BY THE SADDLE AND SITTING POSTURE OF THE HORSE RIDER. THE DESIGN CONFORMS TO THE ERGONOMIC SITTING HABITS, WHICH CAN MAINTAIN A NATURAL UPRIGHT POSTURE AT ANY TIME.



**RANCH OTTOMAN**

**RN640 + [FABRIC]**  
640 (W) x 370 (D) x 510 (H)

Internal steel skeleton structure - mimicking a saddle / Soft leather tail for easy moving / Hidden castors to base / Standard blue, teal or yellow upholstery



**BALL OTTOMAN**, IS THE IDEAL SOLUTION TO BRING SOME COLOUR AND LIFE INTO THE WORKSPACE AND SOFTEN THE ATMOSPHERE. IT IS A DISCREET, BUT WONDERFUL PIECE OF FURNITURE THAT PROVIDES EXTRA SEATING WHEREVER NEEDED.



GREY  
[GR]



GREEN  
[GRN]



ORANGE  
[OR]

## **BALL OTTOMAN**

**BL600 + [FABRIC]**  
600 Ø x 430 (H)

Wooden frame with high density moulded foam / Standard grey, green or orange upholstery



THE **BUDDY POUF**, IS EQUALLY ATTRACTIVE AS IT IS PRACTICAL. A STORAGE COMPARTMENT IS CONCEALED ON THE INSIDE, IDEAL FOR ANYTHING YOU WANT TO HIDE AWAY. THE DEFINED STITCHING GIVES THE DESIGN AN EXTRA EDGE AND ENHANCE THE SUPREME CRAFTSMANSHIP.



GREY  
[GR]

GREEN  
[GRN]

MOSS  
[MS]

TEAL  
[TL]

**BUDDY POUF**

**BD510 + [FABRIC]**  
510 (W) x 510 (D) x 540 (H) x 430 (SH)

Wooden frame with high density foam / Storage compartment / Standard grey, green, moss or teal upholstery



**BUDDY CASTORS**  
[BDCASTOR] - Set of 4

Images shown for display purposes only. Actual finishes may vary.

vetsak



## VETSAK MEDIUM

VSM110V - Velvet Fabric  
VSM110CV - Cord Velour Fabric  
1100 Ø x 700(H)

Medium Vetsak beanbag is approximately 1100 (D) x 700 (H) / Weighs around 21,3kg and contains about 600 litres of upcycled, shredded, memory foam flakes OEKO-TEX-100 standard / Seats one adult comfortably

VELVET FABRIC



CARAMEL



CREME



DARK GREY



LIGHT GREY



MINT



STONE

Machine Washable at 30°C. 100% Polyester



**VETSAK** LARGE

VSL140V - Velvet Fabric  
 VSL140CV - Cord Velour Fabric  
 1400 Ø x 900(H)

Large Vetsak beanbag is about 1400 (D) x 900 (H) / Weighs around 31.5kg and contains about 1000 litres of upcycled, shredded, memory foam flakes OEKO-TEX-100 standard / Seats two adult comfortably



Machine Washable at 30°C. 80% Polyester. 20% Nylon Fabric made from recycled PET Bottles

Images shown for display purposes only. Actual finishes may vary.



## MEET ME

**CORNER MODULE**  
**MME01B + [COM]**  
820 (W) x 820 (D) x 780 (H)

\*Fabric requirements : 3,8m upholstery  
(2,5m Inside back & seat / 1,3m Outside  
back & side borders)

Modular components on tubular steel  
frame in black powder coated finish /  
Upholstered in [COM]

**SLIPPER MODULE**  
**MME02B + [COM]**  
670 (W) x 820 (D) x 780 (H)

\*Fabric requirements : 2,6m upholstery  
(1,6m Inside back & seat / 1m Outside back  
& side borders)

Modular components on tubular steel  
frame in black powder coated finish /  
Upholstered in [COM]

**OTTOMAN**  
**MME03B + [COM]**  
820 (W) x 820 (D) x 450 (H)

\*Fabric requirements : 2m upholstery  
(1,1m Seat / 0,9m Side borders)

Modular components on tubular  
steel frame in black powder coated finish /  
Upholstered in [COM]



**FLEX** IS A DOUBLE CURVED MODULAR SOLUTION THAT IS PRACTICAL TO CONFIGURE. WORK, WAIT, WELCOME OR UNWIND, FLEX GIVES YOU THE FREEDOM TO BE CREATIVE.



## **FLEX**

**FLX01 + [COM]**  
1720 (W) x 800 (D) x 800 (H)

Fixed seat and back double curved module / Steel legs in black painted finish / Upholstered in [COM]

\*Fabric requirements: 9m upholstery



THE **STRONG BOY**, IS ELEGANT, VERSATILE, ADAPTABLE AND MEETS ALL THE NEEDS OF THOSE WHO HAVE TO FURNISH PUBLIC WAITING SPACES.



### **STRONG BOY** THREE SEATER BENCH

**SBY03SI**  
1750 (W) x 680 (D) x 770 (H)

Seat & back in steel with perforated detail / Steel arms & legs with triangular crossbeam / Available in silver painted finish





### **STRONG BOY** FOUR SEATER BENCH

**SBY04SI**  
2320 (W) x 680 (D) x 770 (H)

Seat & back in steel with perforated detail / Steel arms & legs with triangular crossbeam / Available in silver painted finish



## **LA'MIA BENCH WHITE**

**TWO SEATER**  
**LAM02WH**  
**LAM02WH + [COM]** - Upholstered seat  
1250 (W) x 680 (D) x 810 (H)

**THREE SEATER**  
**LAM03WH**  
**LAM03WH + [COM]** - Upholstered seat  
1870 (W) x 680 (D) x 810 (H)

White polypropylene seat & back / Black beam with chrome bench legs / Optional seat upholstered in [COM]

\*Fabric requirement: 0,7m seat upholstery (0,7m for 2 x seats)

100%  
EXCLUSIVE



**LA'MIA**, THE SEAT CAN BE UPHOLSTERED FOR EXTRA COMFORT. IDEAL FOR HIGH TRAFFIC PUBLIC AREAS THAT ARE FREQUENTLY USED.



## **LA'MIA BENCH BLACK**

### **TWO SEATER**

**LAM02BLK**

**LAM02BLK + [COM]** - Upholstered seat  
1250 (W) x 680 (D) x 810 (H)

### **THREE SEATER**

**LAM03BLK**

**LAM03BLK + [COM]** - Upholstered seat  
1870 (W) x 680 (D) x 810 (H)

Black polypropylene seat & back /  
Black beam with black bench legs /  
Optional seat upholstered in [COM]

\*Fabric requirement: 0,7m seat upholstery  
(0,7m for 2 x seats)







**KICCA**, BENCH SEATING IS IDEAL FOR SMALL AND LARGE WAITING ROOMS AND PUBLIC SPACES. CHARACTERISED BY A POLYPROPYLENE SHELL IN VARIOUS COLOURS WITH AN OPTION TO CUSTOMISE WITH AN UPHOLSTERED SEAT PAD OR SHELL.



### KICCA TWO SEATER BENCH

**KCB02 + [COLOUR]**

**KCUB02 + [COLOUR] + [COM]** - Upholstered inner shell

**KCSUB02 + [COLOUR] + [COM]** - Upholstered seat pad  
1250 (W) x 680 (D) x 715 (H)

Black beam with chrome legs / Polypropylene shell available in anthracite, black, blue, green, orange, sand, turquoise & white / Optional upholstered seat pad or inner shell in [COM]

\*Fabric requirements : 1,1m inner shell upholstery / 0,6m seat upholstery (0,6m for 2 x seats)

#### KICCA COLOURS



ANTHRACITE  
[AN]



BLACK  
[BLK]



BLUE  
[BL]



GREEN  
[GRN]



ORANGE  
[OR]



SAND  
[SD]



TURQUOISE  
[TQ]



WHITE  
[WH]



### KICCA THREE SEATER BENCH

**KCB03 + [COLOUR]**

**KCUB03 + [COLOUR] + [COM]** - Upholstered inner shell

**KCSUB03 + [COLOUR] + [COM]** - Upholstered seat pad  
1870 (W) x 680 (D) x 715 (H)

Black beam with chrome legs / Polypropylene shell available in anthracite, black, blue, green, orange, sand, turquoise & white / Optional upholstered seat pad or inner shell in [COM]

\*Fabric requirements : 1,1m inner shell upholstery / 0,6m seat upholstery (0,6m for 2 x seats)





# COFFEE TABLES



THE **HAPPY HOUR** & **PEPE** TABLES ARE VERSATILE AND ELEGANT WITH CLEAN AND SIMPLE LINES THAT FIT IN ANYWHERE.

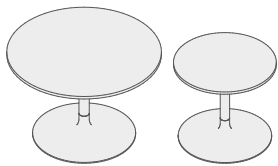

## HAPPY HOUR

COFFEE TABLE - 550 Ø  
**HH550 + [BLK/CH/WH] + [FINISH]**  
 550 Ø x 485 (H)

COFFEE TABLE - 750 Ø  
**HH750 + [BLK/CH/WH] + [FINISH]**  
 750 Ø x 485 (H)

22mm Supalam top with reverse chamfered edge available in 550 Ø & 750 Ø / Tulip base available in Black [BLK], Chrome [CH] or White [WH] / Available in CN Exclusive Supalam finishes, Anthracite & White

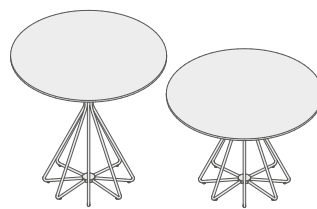

## PEPE

LOW - 525 (H)  
**PPL550 + [AN/WH] + [FINISH]** - 550 Ø  
**PPL750 + [AN/WH] + [FINISH]** - 750 Ø

HIGH - 745 (H)  
**PPH550 + [AN/WH] + [FINISH]** - 550 Ø  
**PPH750 + [AN/WH] + [FINISH]** - 750 Ø

22mm Supalam top with reverse chamfered edge available in 550 Ø & 750 Ø / Steel rod base available in Anthracite [AN] or White [WH] / Available in CN Exclusive Supalam finishes, Anthracite & White

SUPALAM FINISHES



ACACIA [AC]



DARK EUCALYPTUS [DE]



NATURAL WALNUT [NW]



TAORMINA ASH [TA]



TRUE OAK [TO]



ANTHRACITE [AN]



WHITE [WH]



THE **ARUBA** TABLES ARE IDEAL FOR RECEPTION SETTINGS AND THOSE IN-BETWEEN SPACES, CONVERTING ANY SPACE INTO A PLACE TO GET THINGS DONE.

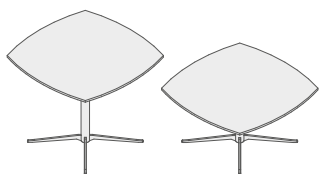

### ARUBA CONVEX SQUARE

LOW - 390 (H)  
**ART7575 + [FINISH]** - Top  
**ARCTLB03 + [BLK/SI/WH]** - Base  
 750 (L) x 750 (W) x 390 (H)

HIGH - 625 (H)  
**ART7575 + [FINISH]** - Top  
**ARCTHB03 + [BLK/SI/WH]** - Base  
 750 (L) x 750 (W) x 625 (H)

22mm Supalam top with reverse chamfered edge / 4-Star base in Black [BLK], Silver [SI] & White [WH] / Available in CN Exclusive Supalam finishes, Anthracite & White

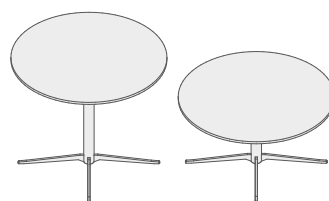

### ARUBA ROUND

LOW - 390 (H)  
**ART750 + [FINISH]** - Top  
**ARCTLB03 + [BLK/SI/WH]** - Base  
 750 Ø x 390 (H)

HIGH - 625 (H)  
**ART750 + [FINISH]** - Top  
**ARCTHB03 + [BLK/SI/WH]** - Base  
 750 Ø x 625 (H)

22mm Supalam top with reverse chamfered edge / 4-Star base in Black [BLK], Silver [SI] & White [WH] / Available in CN Exclusive Supalam finishes, Anthracite & White

SUPALAM FINISHES



Images shown for display purposes only. Actual finishes may vary.



100%  
EXCLUSIVE

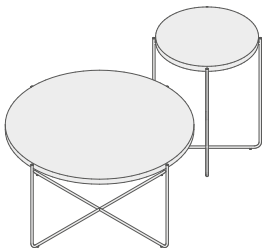

### MOON LAMINATE

**COFFEE TABLE**  
**MNC770 + [FINISH]** - Top  
**MNC800 + [BLK/WH]** - Frame  
 800 Ø x 420 (H)

**SIDE TABLE**  
**MNS420 + [FINISH]** - Top  
**MNS450 + [BLK/WH]** - Frame  
 450 Ø x 550 (H)

25mm Top / Steel round tube frame available in Black [BLK] or White [WH] / Available in CN Exclusive laminates, Anthracite, Stone Grey & White

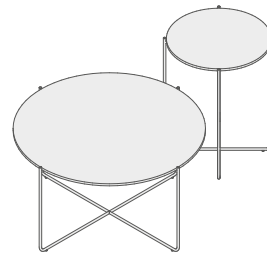

### MOON GLASS

**COFFEE TABLE**  
**MNG800 + [BLK/WH]**  
 800 Ø x 420 (H)

**SIDE TABLE**  
**MNG450 + [BLK/WH]**  
 450 Ø x 550 (H)

10mm Thick toughened glass top with bright polished edge, backpainted with GlassKote™ to match frame / Steel tube frame / Available in Black [BLK] or White [WH]

LAMINATE FINISHES



100%  
EXCLUSIVE



## JENNY COFFEE TABLES

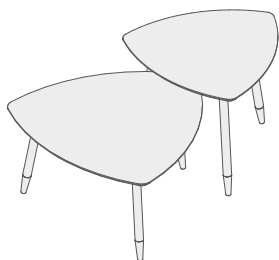

LOW  
**JNT880 + [FINISH]** - Top  
**JN450 + [BLK/WH]** - Jenny Leg 450 (H)

HIGH  
**JNT700 + [FINISH]** - Top  
**JN550 + [BLK/WH]** - Jenny Leg 550 (H)

22mm Supalam top with reverse chamfered edge / Black [BLK] or White [WH] metal legs with tapered solid Oak foot / Available in CN Exclusive Supalam finishes, Anthracite & White

SUPALAM FINISHES



ACACIA  
[AC]



DARK EUCALYPTUS  
[DE]



NATURAL WALNUT  
[NW]



TAORMINA ASH  
[TA]



TRUE OAK  
[TO]



ANTHRACITE  
[AN]



WHITE  
[WH]

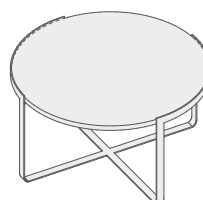

## RUSTIC

COFFEE TABLE  
**RST900 + [FINISH]** - Top  
**RSF900BLK** - Frame  
900 Ø x 490 (H)

25mm Top / Metal frame available in black painted finish / Available in CN Exclusive laminates, Anthracite, Stone Grey & White



100%  
EXCLUSIVE



### MILAN METAL

COFFEE TABLE  
MLC400 + [B/W] + [FINISH]  
750 Ø x 400 (H)

SIDE TABLE  
MLS500 + [B/W] + [FINISH]  
550 Ø x 500 (H)

22mm Supalam top with reverse chamfered edge / Steel round tube frame available in Black [B] or White [W] / Available in CN Exclusive Supalam finishes, Anthracite & White

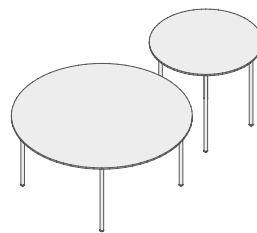

### SELENA

COFFEE TABLE  
SLC800BLK  
800 Ø x 375 (H)

SIDE TABLE  
SLS500BLK  
500 Ø x 450 (H)

18mm Black laminate top with chamfered edge / Black metal frame

SUPALAM FINISHES



ACACIA  
[AC]



DARK EUCALYPTUS  
[DE]



NATURAL WALNUT  
[NW]



TAORMINA ASH  
[TA]



TRUE OAK  
[TO]



ANTHRACITE  
[AN]



WHITE  
[WH]

## **BARON** OBLONG

TOP  
**BT8970 + [FINISH]** - 890 x 700 Oblong

BASE  
**BA438BLK** - 438 (H)

12mm Thick solid core top, available in black & white /  
4-Star aluminium base in black painted finish



## **TRAY** COFFEE TABLE

**TR800BLK**  
800 Ø x 435 (H)

18mm Black laminate tray top /  
Black metal frame





## ONE UP

**COFFEE TABLE**  
**UBLT1260 + [FINISH]** - Top  
**OUF1260BLK** - Frame  
 1200 (L) x 600 (W) x 425 (H)

**SIDE TABLE**  
**UBLT805 + [FINISH]** - Top  
**OUF805BLK** - Frame  
 800 (L) x 500 (W) x 525 (H)

25mm Top / Rectangular tube frame available in black painted finish / Available in CN Exclusive laminates, Anthracite, Stone Grey & White



## URBAN FUNK

**COFFEE TABLE**  
**UBFT1260 + [FINISH]** - Top  
**UBF1260 + [BLK/SI/WH]** - Frame  
 1200 (L) x 600 (W) x 436 (H)

**UBFT1480 + [FINISH]** - Top  
**UBF1480 + [BLK/SI/WH]** - Frame  
 1400 (L) x 800 (W) x 436 (H)

**UBFT800 + [FINISH]** - Top  
**UBF800 + [BLK/SI/WH]** - Frame  
 800 (L) x 800 (W) x 436 (H)

**SIDE TABLE**  
**UBFT600 + [FINISH]** - Top  
**UBF600 + [BLK/SI/WH]** - Frame  
 600 (L) x 600 (W) x 536 (H)

16mm Top / Square tube frame available in Black [BLK], Silver [SI] or White [WH] / Available in CN Exclusive laminates, Anthracite, Stone Grey & White



LAMINATE FINISHES

- 

ACACIA  
[AC] / [ACA] / [ACB] / [ACS] / [ACW]
- 

DARK EUCALYPTUS  
[DE] / [DEA] / [DEB] / [DEW]
- 

NATURAL WALNUT  
[NW] / [NWA] / [NWB] / [NWW]
- 

TAORMINA ASH  
[TA] / [TAA] / [TAB] / [TAS] / [TAW]
- 

TRUE OAK  
[TO] / [TOA] / [TOB] / [TOW]

**ECOCENTRIC**

COFFEE TABLE  
**ECO1375 + [FINISH]**  
1350 (L) x 750 (W) x 430 (H)

SIDE TABLE  
**ECO750 + [FINISH]**  
750 (L) x 750 (W) x 430 (H)

25mm Laminate construction with 16mm feature panel in paired finish / Available in CN Exclusive laminates paired with anthracite, black, stone grey & white



**URBAN LOOP**

COFFEE TABLE  
**UBLT1260 + [FINISH]** - Top  
**UBL1260 + [BLK/SI/WH]** - Frame  
1200 (L) x 600 (W) x 400 (H)

SIDE TABLE  
**UBLT600 + [FINISH]** - Top  
**UBL600 + [BLK/SI/WH]** - Frame  
600 (L) x 600 (W) x 520 (H)

25mm Top / Square tube frame available in Black [BLK], Silver [SI] or White [WH] / Available in CN Exclusive laminates, Anthracite, Stone Grey & White

LAMINATE FINISHES

- 

ACACIA  
[AC]
- 

DARK EUCALYPTUS  
[DE]
- 

NATURAL WALNUT  
[NW]
- 

TAORMINA ASH  
[TA]
- 

TRUE OAK  
[TO]
- 

ANTHRACITE  
[AN]
- 

STONE GREY  
[SG]
- 

WHITE  
[WH]

100%  
EXCLUSIVE



LIGHTWEIGHT, MOBILE AND EASY TO MOVE OVER YOUR LAP OR TUCK OVER LOUNGE SEATING. THE **BARON & BARONESS** LAPTOP TABLES ARE IDEAL FOR RECEPTION SETTINGS AND THOSE IN-BETWEEN SPACES, CONVERTING ANY SPACE INTO A PLACE TO GET THINGS DONE.

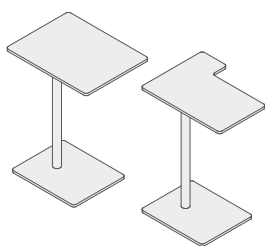

### **BARON** LAPTOP TABLES

**HANDED LAPTOP TABLE**  
**BRL650 + [BLK/WH]** - Non-handed  
**BRL650 + [L/R] + [BLK/WH]** - Handed  
370 (W) x 475 (L) x 650 (H)

12mm Black [BLK] or White [WH] solid core top / Black metal pole on a 12mm black solid core base



**OBLONG LAPTOP TABLE**  
**BRLO650 + [BLK/WH]**  
393 (W) x 500 (L) x 650 (H)

12mm Black [BLK] or White [WH] solid core top / Black metal pole on a 12mm black solid core base



**BARONESS LAPTOP TABLE**  
**BRN650 + [FINISH]**  
370 (W) x 475 (L) x 650 (H)

16mm Top / Black metal pole on a 12mm black solid core base / Available in CN Exclusive laminates, Anthracite, Stone Grey & White

#### LAMINATE FINISHES



ACACIA  
[ACB]



DARK EUCALYPTUS  
[DEB]



NATURAL WALNUT  
[NWB]



TAORMINA ASH  
[TAB]



TRUE OAK  
[TOB]



ANTHRACITE  
[ANB]



STONE GREY  
[SGB]



WHITE  
[WHB]



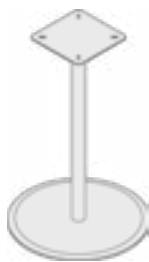

### **BARON DISC**

**BASES**

**BD438BLK** - 438 (H)  
**BD638BLK** - 638 (H)

**TOPS**

**BT525R + [BLK/WH]** - 525 Ø Round  
**BT640R + [BLK/WH]** - 640 Ø Round  
**BT525S + [BLK/WH]** - 525 x 525 Square  
**BT640S + [BLK/WH]** - 640 x 640 Square

12mm Black [BLK] or White [WH] solid core top /  
 Black metal pole on 400Ø x 12mm black solid core  
 base



### **BARON 4-STAR**

**BASES**

**BA438BLK** - 438 (H)  
**BA538BLK** - 538 (H)  
**BA638BLK** - 638 (H)

**TOPS**

**BT640R + [BLK/WH]** - 640 Ø Round  
**BT640S + [BLK/WH]** - 640 x 640 Square  
**BT897O + [BLK/WH]** - 890 x 700 Oblong

12mm Black [BLK] or White [WH] solid core top /  
 4-Star aluminium base in black painted finish





# BOARDROOM



**DIAMOND LOOP** IS YOUR IDEAL SOLUTION FOR MEETING & COLLABORATION SPACES. EVERY DETAIL FROM ITS SPECIAL TRIANGULAR SHAPE AND STRONG GEOMETRIC LINES, HARMONISE BEAUTIFULLY IN ANY MODERN OFFICE SPACE.

### **DIAMOND LOOP** BOARDROOM

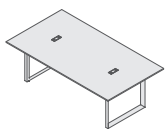

**BOARDROOM - 2200**  
**GTSM2212 + [FINISH]** - Top  
**DAL1880BLK** - Frame  
 2200 (L) x 1200 (W) x 738 (H)

16mm Top with 2 x black cable outlets / Black triangular leg profile / Available in CN Exclusive laminates, Anthracite, Stone Grey & White

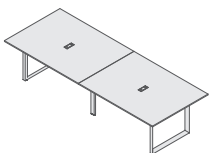

**BOARDROOM - 3200**  
**GTSM3212 + [FINISH]** - Top  
**DAL2880BLK** - Frame  
 3200 (L) x 1200 (W) x 738 (H)

16mm 2 - Piece top with 2 x black cable outlets / Black triangular leg profile with recessed intermediate leg / Available in CN Exclusive laminates, Anthracite, Stone Grey & White

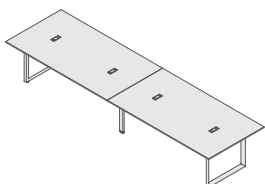

**BOARDROOM - 4400**  
**GTSM4412 + [FINISH]** - Top  
**DAL4080BLK** - Frame  
 4400 (L) x 1200 (W) x 738 (H)

16mm 2 - Piece top with 4 x black cable outlets / Black triangular leg profile with recessed intermediate leg / Available in CN Exclusive laminates, Anthracite, Stone Grey & White



LAMINATE FINISHES

-  ACACIA [AC]
-  DARK EUCALYPTUS [DE]
-  NATURAL WALNUT [NW]
-  TAORMINA ASH [TA]
-  TRUE OAK [TO]
-  ANTHRACITE [AN]
-  STONE GREY [SG]
-  WHITE [WH]



Images shown for display purposes only. Actual finishes may vary.



100%  
EXCLUSIVE

**DIAMOND**, LIGHT AND MINIMALIST, CHARACTERISED BY ITS SPECIAL TRIANGULAR SHAPED STEEL FRAME AND THIN ELEGANT FLOATING TOP.

### **DIAMOND OPEN MEETING**

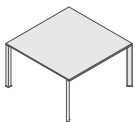

MEETING - 1200  
**GTSM1212 + [FINISH]** - Top  
**DA1200MBLK** - Frame  
 1200 (L) x 1200 (W) x 738 (H)

16mm Top / Black triangular leg profile / Available in CN Exclusive laminates, Anthracite, Stone Grey & White

### **DIAMOND OPEN BOARDROOM**

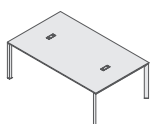

BOARDROOM - 2000  
**GTSM2012 + [FINISH]** - Top  
**DA2012BBLK** - Frame  
 2000 (L) x 1200 (W) x 738 (H)

16mm Top with 2 x black cable outlets / Black triangular leg profile / Available CN Exclusive laminates, Anthracite, Stone Grey & White



LAMINATE FINISHES

-  ACACIA [AC]
-  DARK EUCALYPTUS [DE]
-  NATURAL WALNUT [NW]
-  TAORMINA ASH [TA]
-  TRUE OAK [TO]
-  ANTHRACITE [AN]
-  STONE GREY [SG]
-  WHITE [WH]

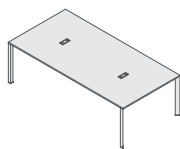

**DIAMOND OPEN BOARDROOM**

**BOARDROOM - 2400**  
**GTSM2412 + [FINISH]** - Top  
**DA2400BLK** - Frame  
 2400 (L) x 1200 (W) x 738 (H)

16mm Top with 2 x black cable outlets / Black triangular leg profile / Available in CN Exclusive laminates, Anthracite, Stone Grey & White

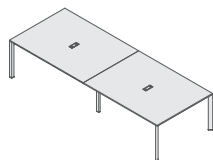

**BOARDROOM - 3200**  
**GTSM3212 + [FINISH]** - Top  
**DA3200BLK** - Frame  
 3200 (L) x 1200 (W) x 738 (H)

16mm 2 - Piece top with 2 x black cable outlets / Black triangular leg profile with recessed intermediate leg / Available in CN Exclusive laminates, Anthracite, Stone Grey & White

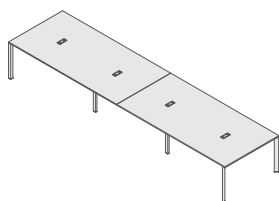

**BOARDROOM - 4800**  
**GTSM4812 + [FINISH]** - Top  
**DA4800BLK** - Frame  
 4800 (L) x 1200 (W) x 738 (H)

16mm 2 - Piece top with 4 x black cable outlets / Black triangular leg profile with recessed intermediate legs / Available in CN Exclusive laminates, Anthracite, Stone Grey & White

Images shown for display purposes only. Actual finishes may vary.



100%  
EXCLUSIVE

**RADIUS**, SUPPORTS THE NEW WAYS IN WHICH WE WORK AND FUNCTION, OFFERING FLEXIBLE, ADAPTABLE OPTIONS FOR BOARDROOM AND COLLABORATIVE SPACES.

### RADIUS MEETING

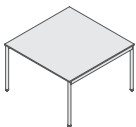

MEETING - 1200  
GTSM1212 + [FINISH] - Top  
RD1200MBLK - Frame  
1200 (L) x 1200 (W) x 738 (H)

16mm Top / Black round leg profile / Available in CN Exclusive laminates, Anthracite, Stone Grey & White

### RADIUS BOARDROOM

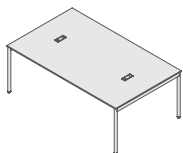

BOARDROOM - 2000  
GTSM2012 + [FINISH] - Top  
RD2012BBLK - Frame  
2000 (L) x 1200 (W) x 738 (H)

16mm Top with 2 x black cable outlets / Black round leg profile / Available in a choice of CN Exclusive laminates, Anthracite, Stone Grey & White

#### LAMINATE FINISHES



ACACIA  
[AC]



DARK EUCALYPTUS  
[DE]



NATURAL WALNUT  
[NW]



TAORMINA ASH  
[TA]



TRUE OAK  
[TO]



ANTHRACITE  
[AN]



STONE GREY  
[SG]



WHITE  
[WH]





## RADIUS BOARDROOM

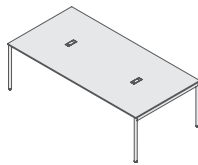

**BOARDROOM - 2400**  
**GTSM2412 + [FINISH]** - Top  
**RD2400BLK** - Frame  
 2400 (L) x 1200 (W) x 738 (H)

16mm Top with 2 x black cable outlets / Black round leg profile / Available in CN Exclusive laminates, Anthracite, Stone Grey & White

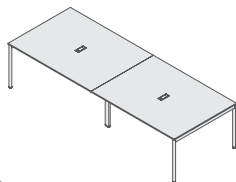

**BOARDROOM - 3200**  
**GTSM3212 + [FINISH]** - Top  
**RD3200BLK** - Frame  
 3200 (L) x 1200 (W) x 738 (H)

16mm 2 - Piece top with 2 x black cable outlets / Black round leg profile / Available in CN Exclusive laminates, Anthracite, Stone Grey & White

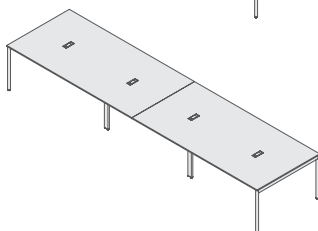

**BOARDROOM - 4800**  
**GTSM4812 + [FINISH]** - Top  
**RD4800BLK** - Frame  
 4800 (L) x 1200 (W) x 738 (H)

16mm 2 - Piece top with 4 x black cable outlets / Black round leg profile / Available in CN Exclusive laminates, Anthracite, Stone Grey & White





## Y-FRAME, WHERE DESIGN AND ENGINEERING FUSE TO CREATE A CLEAN, LIGHT MODERN SOLUTION FOR BOARDROOM AND COLLABORATE TEAM SPACES.

### Y-FRAME MEETING

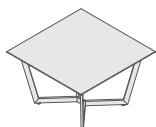

**SQUARE - 1200**  
**YFT1212 + [FINISH]** - Top  
**YF1212 + [BLK/CH/WH]** - Frame  
1200 (L) x 1200 (W) x 722 (H)

22mm Supalam top with reverse chamfered edge / 25 x 60mm Rectangular tube frame available in Black [BLK], Charcoal [CH] or White [WH] / Available in CN Exclusive Supalam finishes, Anthracite or White

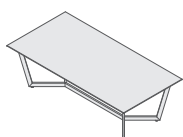

**RECTANGULAR - 2400**  
**YFT2412 + [FINISH]** - Top  
**YF2412 + [BLK/CH/WH]** - Frame  
2400 (L) x 1200 (W) x 722 (H)

22mm Supalam top with reverse chamfered edge / 25 x 60mm Rectangular tube frame available in Black [BLK], Charcoal [CH] or White [WH] / Available in CN Exclusive Supalam finishes, Anthracite or White

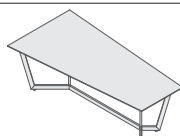

**TAPERED - 2400**  
**YFT2480 + [FINISH]** - Top  
**YF2480 + [BLK/CH/WH]** - Frame  
2400 (L) x 1200 - 800 (W) x 722 (H)

### Y-FRAME BOARDROOM

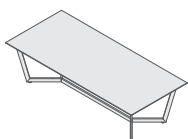

**BOARDROOM - 2700**  
**YFT2712 + [FINISH]** - Top  
**YF2712 + [BLK/CH/WH]** - Frame  
2700 (L) x 1200 (W) x 722 (H)

22mm Supalam top with reverse chamfered edge / 25 x 60mm Rectangular tube frame available in Black [BLK], Charcoal [CH] or White [WH] / Available in CN Exclusive Supalam finishes, Anthracite or White

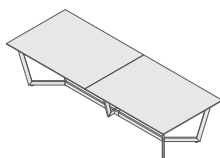

**BOARDROOM - 3200**  
**YFT3212 + [FINISH]** - Top  
**YF3212 + [BLK/CH/WH]** - Frame  
3200 (L) x 1200 (W) x 722 (H)

22mm 2 - Piece Supalam top with reverse chamfered edge / 25 x 60mm Rectangular tube frame available in Black [BLK], Charcoal [CH] or White [WH] / Available in CN Exclusive Supalam finishes, Anthracite or White

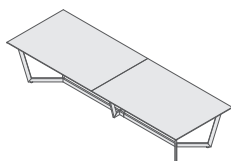

**BOARDROOM - 3600**  
**YFT3612 + [FINISH]** - Top  
**YF3612 + [BLK/CH/WH]** - Frame  
3600 (L) x 1200 (W) x 722 (H)

22mm 2 - Piece Supalam top with reverse chamfered edge / 25 x 60mm Rectangular tube frame available in Black [BLK], Charcoal [CH] or White [WH] / Available in CN Exclusive Supalam finishes, Anthracite or White

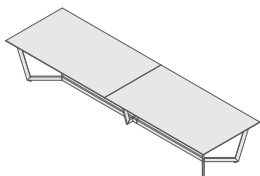

**BOARDROOM - 4200**  
**YFT4212 + [FINISH]** - Top  
**YF4212 + [BLK/CH/WH]** - Frame  
4200 (L) x 1200 (W) x 722 (H)

22mm 2 - Piece Supalam top with reverse chamfered edge / 25 x 60mm Rectangular tube frame available in Black [BLK], Charcoal [CH] or White [WH] / Available in CN Exclusive Supalam finishes, Anthracite or White



**JOINING PLATE**  
**UJP96**  
140 (L) x 44 (W) x 3 mm

Standard hardware for joining 2-piece tops / Available in silver

#### SUPALAM FINISHES



ACACIA  
[AC]



DARK EUCALYPTUS  
[DE]



NATURAL WALNUT  
[NW]



TAORMINA ASH  
[TA]



TRUE OAK  
[TO]



ANTHRACITE  
[AN]



WHITE  
[WH]



**HUNTSMAN WOOD**, HAS A CLEAN LINEAR DESIGN WHERE WOOD IS USED TO SHOW SUSTAINABILITY, BEAUTY AND CRAFTSMANSHIP IN A BEAUTIFUL MODERN BOARDROOM TABLE.

### HUNTSMAN WOOD

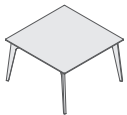

MEETING - 1200  
**HT1212BLK**  
 1200 (L) x 1200 (W) x 737 (H)

12mm Black solid core top with polished edges / Metal understructure in black finish with solid Oak-stained legs

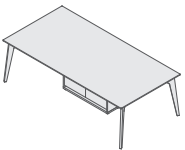

BOARDROOM - 2400  
**HT2412BLK**  
 2400 (L) x 1200 (W) x 737 (H)

12mm Black solid core top with polished edges / Metal understructure in black finish with solid Oak-stained legs / 1 x Stabilising power box with hinge doors in black laminate

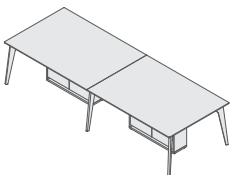

BOARDROOM - 3300  
**HT3312BLK**  
 3300 (L) x 1200 (W) x 737 (H)

12mm 2 - Piece black solid core top with polished edges / Metal understructure in black finish with solid Oak-stained legs / 2 x Stabilising power boxes with hinge doors in black laminate

\*Power cut-outs to be specified on order  
 \*\*Power box : 900 (W) x 250 (D) x 700 (H)



**HALLMARK**, FEATURES A DISTINCTIVE SOLID TURNED WOODEN LEG, EXPLORING ALL THE POSSIBILITIES OF THE OFFICE TABLE.

SUPALAM FINISHES



### HALLMARK MEETING

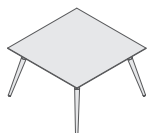

**HLM1212 + [FINISH]**  
1200 (L) x 1200 (W) x 722 (H)

22mm Supalam top with reverse chamfered edge / Metal under structure in anthracite or white painted finish with turned solid Oak legs / Available in Anthracite & White Supalam

### HALLMARK BOARDROOM

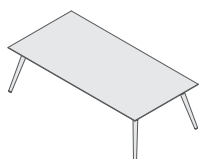

**HLM2412 + [FINISH]**  
2400 (L) x 1200 (W) x 722 (H)

22mm Supalam top with reverse chamfered edge / Metal under structure in anthracite or white painted finish with turned solid Oak legs / Available in Anthracite & White Supalam



100%  
EXCLUSIVE

**HUNTSMAN STEEL**, HAS A MODERN REFINED STEEL LEG PROFILE WITH A VISIBLY LIGHT AESTHETIC.

### HUNTSMAN STEEL

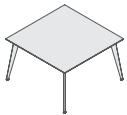

MEETING - 1200  
**HTMS1212 + [A/B] + [FINISH]**  
1200 (L) x 1200 (W) x 722 (H)

22mm Supalam top with reverse chamfered edge / Metal understructure in Anthracite [A] or Black [B] painted finish / Available in CN Exclusive Supalam finishes, Anthracite & White

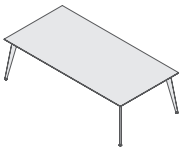

BOARDROOM - 2400  
**HTMS2412 + [A/B] + [FINISH]**  
2400 (L) x 1200 (W) x 722 (H)

22mm Supalam top with reverse chamfered edge / Metal understructure in Anthracite [A] or Black [B] painted finish / Available in CN Exclusive Supalam finishes, Anthracite & White

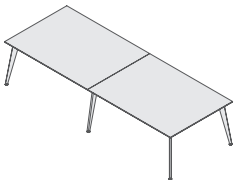

BOARDROOM - 3300  
**HTMS3212 + [A/B] + [FINISH]**  
3200 (L) x 1200 (W) x 722 (H)

22mm 2 - Piece Supalam top with reverse chamfered edge / Metal understructure in Anthracite [A] or Black [B] painted finish / Available in CN Exclusive Supalam finishes, Anthracite & White

\*Power cut-outs to be specified on order



SUPALAM FINISHES



ACACIA  
[AC]



DARK EUCALYPTUS  
[DE]



NATURAL WALNUT  
[NW]



TAORMINA ASH  
[TA]



TRUE OAK  
[TO]



ANTHRACITE  
[AN]



WHITE  
[WH]

Images shown for display purposes only. Actual finishes may vary.







**DIAGONAL STREET**, WITH ITS ANGLED SOLID WOOD LEGS ENSURING THERE'S ROOM FOR EVERYONE TO GATHER AROUND.



### DIAGONAL STREET MEETING

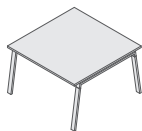

**DST1212 + [FINISH]** - Top  
**DS1212WD** - White understructure  
**DS1212SWD** - Anthracite understructure  
 1200 (L) x 1200 (W) x 725 (H)

25mm Top / 60 x 40mm Solid Oak legs with metal understructure in white or anthracite painted finish / Available in Natural Walnut, Anthracite & White laminates

### DIAGONAL STREET BOARDROOM

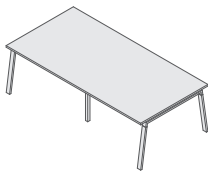

BOARDROOM - 2400  
**DST2412 + [FINISH]** - Top  
**DS2412WD** - White understructure  
**DS2412SWD** - Anthracite understructure  
 2400 (L) x 1200 (W) x 725 (H)

25mm Top / 60 x 40mm Solid Oak legs with metal understructure in white or anthracite painted finish / Available in Natural Walnut, Anthracite & White laminates

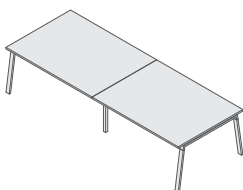

BOARDROOM - 3200  
**DST3212 + [FINISH]** - Top  
**DS3212WD** - White understructure  
**DS3212SWD** - Anthracite understructure  
 3200 (L) x 1200 (W) x 725 (H)

25mm 2 - Piece top / 60 x 40mm Solid Oak legs with metal understructure in white or anthracite painted finish / Available in Natural Walnut, Anthracite & White laminates

#### LAMINATE FINISHES

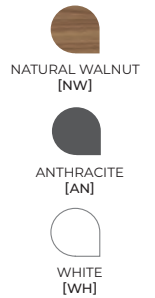





**BRAINSTORM**, A REFRESHING ANTIDOTE TO THE TRADITIONAL CONFERENCE ROOM TABLE. INSIDE OR OUTSIDE A MEETING ROOM, THIS RANGE IS PERFECT FOR LONG SESSIONS OR SHORT BURSTS OF CREATIVE ENERGY.

### BRAINSTORM BOARDROOM

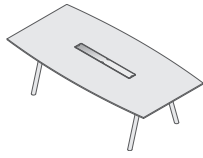

BOARDROOM - 2400  
**EVBB2400 + [FINISH] + [PXBLK/PXW]** - Black legs  
**EVB2400 + [FINISH] + [PXBLK/PXW]** - Silver legs  
**EWB2400 + [FINISH] + [PXBLK/PXW]** - White legs  
 2400 (L) x 1200 (W) x 722 (H)

22mm Supalam top with reverse chamfered edge / Black [BLK], Silver [SI] or White [WH] painted legs / Perspex inlay in Matt Black [PXBLK] or Polar White [PXW] / Available in CN Exclusive Supalam finishes, Anthracite & White

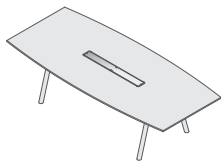

BOARDROOM - 2700  
**EVBB2700 + [FINISH] + [PXBLK/PXW]** - Black legs  
**EVB2700 + [FINISH] + [PXBLK/PXW]** - Silver legs  
**EWB2700 + [FINISH] + [PXBLK/PXW]** - White legs  
 2700 (L) x 1200 (W) x 722 (H)

22mm Supalam top with reverse chamfered edge / Black [BLK], Silver [SI] or White [WH] painted legs / Perspex inlay in Matt Black [PXBLK] or Polar White [PXW] / Available in CN Exclusive Supalam finishes, Anthracite & White

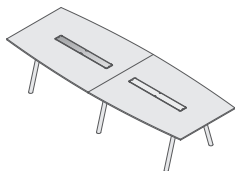

BOARDROOM - 3200  
**EVBB3200 + [FINISH] + [PXBLK/PXW]** - Black legs  
**EVB3200 + [FINISH] + [PXBLK/PXW]** - Silver legs  
**EWB3200 + [FINISH] + [PXBLK/PXW]** - White legs  
 3200 (L) x 1200 (W) x 722 (H)

22mm 2 - Piece Supalam top with reverse chamfered edge / Black [BLK], Silver [SI] or White [WH] painted legs / Perspex inlay in Matt Black [PXBLK] or Polar White [PXW] / Available in CN Exclusive Supalam finishes, Anthracite & White

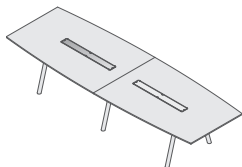

BOARDROOM - 3600  
**EVBB3600 + [FINISH] + [PXBLK/PXW]** - Black legs  
**EVB3600 + [FINISH] + [PXBLK/PXW]** - Silver legs  
**EWB3600 + [FINISH] + [PXBLK/PXW]** - White legs  
 3600 (L) x 1200 (W) x 722 (H)

22mm 2 - Piece Supalam top with reverse chamfered edge / Black [BLK], Silver [SI] or White [WH] painted legs / Perspex inlay in Matt Black [PXBLK] or Polar White [PXW] / Available in CN Exclusive Supalam finishes, Anthracite & White

#### SUPALAM FINISHES



ACACIA [AC]



DARK EUCALYPTUS [DE]



NATURAL WALNUT [NW]



TAORMINA ASH [TA]



TRUE OAK [TO]



ANTHRACITE [AN]



WHITE [WH]

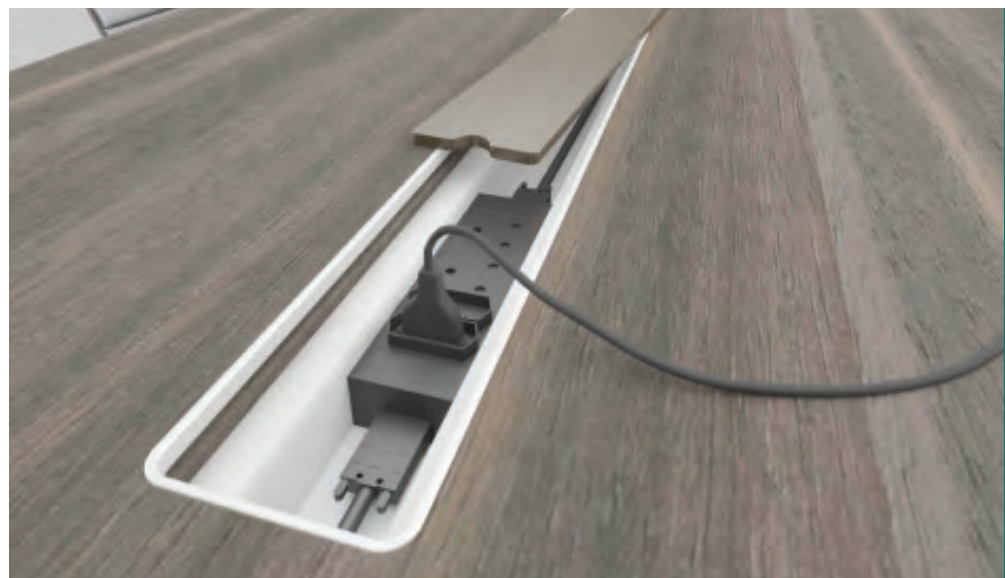



**ALLURE**, BIG & BOLD PEDESTAL BASED BOARDROOM TABLE THAT BOASTS A TWO-TONE FINISH WITH LAMINATE INLAYED TOP.

### ALLURE

MEETING - 1200  
**ALU212 + [FINISH]**  
 1200 (L) x 1200 (W) x 738 (H)

38mm Top with inlay in paired finish / Pedestal base with hinge door in paired finish / Available in CN Exclusive laminates paired with anthracite, black or stone grey

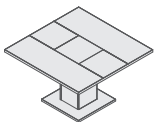

BOARDROOM - 2400  
**ALU2412 + [FINISH]**  
 2400 (L) x 1200 (W) x 738 (H)

38mm Top with inlay in paired finish / 2 x Pedestal bases with hinge door in paired finish / Available in CN Exclusive laminates paired with anthracite, black or stone grey

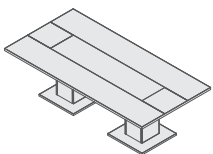

#### LAMINATE FINISHES

ACACIA  
 [ACA] / [ACB] / [ACS]

DARK EUCALYPTUS  
 [DEA] / [DEB]

NATURAL WALNUT  
 [NWA] / [NWB]

TAORMINA ASH  
 [TAA] / [TAB] / [TAS]

TRUE OAK  
 [TOA] / [TOB]



Images shown for display purposes only. Actual finishes may vary.



100%  
EXCLUSIVE

**ECOCENTRIC** ACCOMODATES A WIDE VARIETY OF SIZES WITH GENEROUS PROPORTIONS. PEDESTAL BASE WITH HINGE DOOR ALLOWING EASY ACCESS TO POWER CABLES.

### ECOCENTRIC MEETING

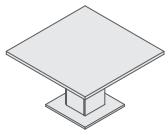

**ECOR1212 + [FINISH]**

1200 (L) x 1200 (W) x 738 (H)

38mm Top / 1 x Pedestal base with hinge door in paired finish / Available in CN Exclusive laminates paired with anthracite, black or stone grey

### ECOCENTRIC BOARDROOM 2400

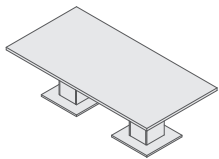

**ECOR2412 + [FINISH]**

2400 (L) x 1200 (W) x 738 (H)

38mm Top / 2 x Pedestal bases with hinge door in paired finish / Available in CN Exclusive laminates paired with anthracite, black or stone grey

### ECOCENTRIC BOARDROOM 3200

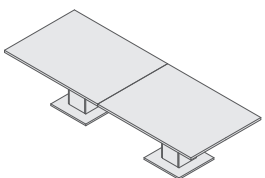

**ECOR3212 + [FINISH]**

3200 (L) x 1200 (W) x 738 (H)

38mm 2 - Piece top / 2 x Pedestal bases with hinge door in paired finish / Available in CN Exclusive laminates paired with anthracite, black or stone grey

LAMINATE FINISHES



ACACIA  
[ACA] / [ACB] / [ACS]



DARK EUCALYPTUS  
[DEA] / [DEB]



NATURAL WALNUT  
[NWA] / [NWB]



TAORMINA ASH  
[TAA] / [TAB] / [TAS]



TRUE OAK  
[TOA] / [TOB]

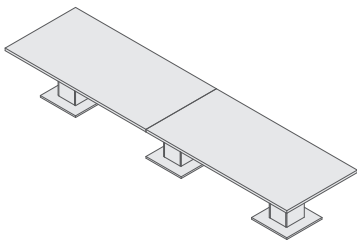

### **ECOCENTRIC BOARDROOM 4800**

**ECOR4812 + [FINISH]**  
4800 (L) x 1200 (W) x 738 (H)

38mm 2 - Piece top / 3 x Pedestal bases with hinge door in paired finish / Available in CN Exclusive laminates paired with anthracite, black or stone grey



**JOINING PLATE UJP96**  
140 (L) x 44 (W) x 3 mm

Standard hardware for joining 2-piece tops / Available in silver

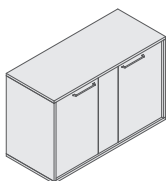

### **ECOCENTRIC SERVER**

**ECO1490 + [FINISH]**  
1400 (L) x 600 (W) x 949 (H)  
\*Fits 120L - 130L fridge **[F130]**

2 x Hinge doors & concealed wine rack / Includes timber shelves / Available in CN Exclusive laminates paired with anthracite, black or stone grey

\*When pairing, door fronts will be in paired finish



100%  
EXCLUSIVE

**LEO** BOARDROOM TABLE LENDS ITSELF TO BRAINSTORMING SESSIONS AND EXCHANGE OF OPINIONS. THE BOLD CHARACTERISTIC SQUARE LEGS SUPPORT A MELAMINE WORKTOP, CREATING A TABLE THAT FITS EFFORTLESSLY INTO ANY WORKSPACE.

### LEO MODULAR BOARDROOM

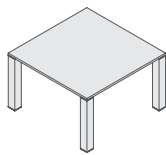

**LEO1212 + [FINISH]** - 1200 Top  
1200 (L) x 1200 (W)  
\*1200 Top is drilled for 4 x Leo end legs

**LEO1612 + [FINISH]** - 1600 Top  
1600 (L) x 1200 (W)  
\*1600 Top is drilled for 4 x Leo end legs

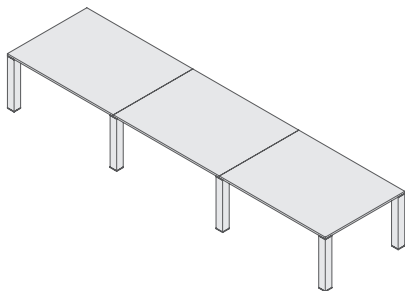

**LEOE1612 + [FINISH]** - End Top  
1600 (L) x 1200 (W)  
\*End top is drilled for 2 x Leo end legs & 2 x Leo shared legs

**LEOM1612 + [FINISH]** - Mid Top  
1600 (L) x 1200 (W)  
\*Mid top is drilled for 4 x Leo shared legs

**LEO700 + [AN/BLK/SI]** - End Leg 700 (H)  
**LEO700S + [AN/BLK/SI]** - Shared Leg\* 700 (H)

25mm Rectangular top with stiffening bars / Leo metal leg in Anthracite [AN], Black [BLK] or Silver [SI] finish with polished die-cast aluminium ends / Available in CN Exclusive laminates, Anthracite, Stone Grey & White

\*Leo shared leg is used when two tops are joined





LAMINATE FINISHES

-  ACACIA [AC]
-  DARK EUCALYPTUS [DE]
-  NATURAL WALNUT [NW]
-  TAORMINA ASH [TA]
-  TRUE OAK [TO]
-  ANTHRACITE [AN]
-  STONE GREY [SG]
-  WHITE [WH]



Anthracite



Black



Silver



**URBAN**, A SIMPLE AND PRACTICAL TABLE THAT BRINGS PEOPLE TOGETHER FOR PROJECT WORK, IMPROMPTU MEETINGS AND TEAM CATCH UPS.

### URBAN BOARDROOM

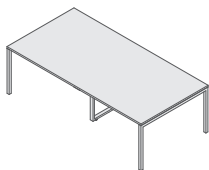

BOARDROOM - 2400  
**UBT2412 + [FINISH]** - Top  
**UBB2412 + [BLK/SI/WH]** - Frame  
 2400 (L) x 1200 (W) x 725 (H)

25mm Top / Black [BLK], Silver [SI] or White [WH] painted frame with recessed intermediate leg / Available in CN Exclusive laminates, Anthracite, Stone Grey & White

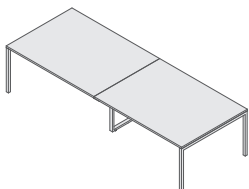

BOARDROOM - 3200  
**UBT3212 + [FINISH]** - Top  
**UBB3212 + [BLK/SI/WH]** - Frame  
 3200 (L) x 1200 (W) x 725 (H)

25mm 2-Piece top / Black [BLK], Silver [SI] or White [WH] painted frame with recessed intermediate leg / Available in CN Exclusive laminates, Anthracite, Stone Grey & White

### URBAN OPTIONAL CABLE TRAYS

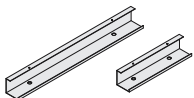

**UBP450 + [BLK/SI/WH]**  
 450 (L) x 90 (W) x 90 (H)

**UBP900 + [BLK/SI/WH]**  
 900 (L) x 90 (W) x 90 (H)

Available in Black [BLK], Silver [SI] or White [WH]

#### LAMINATE FINISHES



ACACIA  
[AC]



DARK EUCALYPTUS  
[DE]



NATURAL WALNUT  
[NW]



TAORMINA ASH  
[TA]



TRUE OAK  
[TO]



ANTHRACITE  
[AN]



STONE GREY  
[SG]



WHITE  
[WH]



## URBAN MEETING

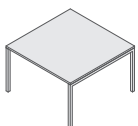

UBT1212 + [FINISH] - Top  
 UBM1212 + [BLK/SI/WH] - Frame  
 1200 (L) x 1200 (W) x 725 (H)

25mm Top / Black [BLK], Silver [SI] or White [WH] painted frame / Available in CN  
 Exclusive laminates, Anthracite, Stone Grey & White



100%  
EXCLUSIVE

WITH COLLABORATIVE TABLES NOW CENTRAL TO GREAT SMART WORKING ENVIRONMENTS **KEYWORK**, NOT ONLY BRINGS PEOPLE TOGETHER TO WORK, BUT ALSO TO PLAY.

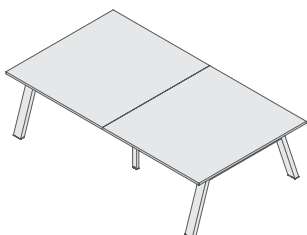

### KEYWORK MEETING

KWT2715 + [FINISH] - Top  
KW3215 + [BLK/WH] - Understructure  
2700 (L) x 1500 (W) x 725 (H)

25mm 2-Piece top / Keywork metal understructure  
available in Black [BLK] or White [WH] / Available in CN  
Exclusive laminates, Anthracite, Stone Grey & White

Accessories not included. Can be purchased from your local sports store.



**RONDO**, CREATES AN ENVIRONMENT FOR MAXIMUM PRODUCTIVITY AND IDEAS. RONDO FEATURES A CANOPY FOR INCLUDING SILK OR LIVING PLANTS.

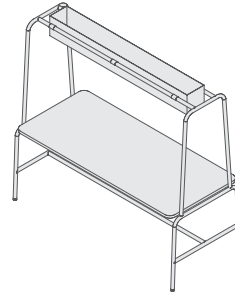

### **RONDO MEETING WITH CANOPY**

**RNT1880 + [FINISH]** - Top  
**RN1817BLK** - Frame including canopy  
 1866 (L) x 805 (W) x 1769 (H)

25mm top with rounded corners / Round tube frame with canopy & flower box in black painted finish / Available in CN Exclusive laminates, Anthracite, Stone Grey & White

#### **PLANT SPECIFICATION**

Silk plants planted into 2-piece 1500 (W) x 190 (D) x 180 (H) Polystyrene base that is painted brown to the top and supplied with bark chips

#### LAMINATE FINISHES

-  ACACIA [AC]
-  DARK EUCALYPTUS [DE]
-  NATURAL WALNUT [NW]
-  TAORMINA ASH [TA]
-  TRUE OAK [TO]
-  ANTHRACITE [AN]
-  STONE GREY [SG]
-  WHITE [WH]

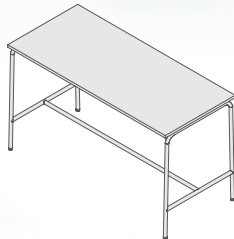

### **RONDO HIGH MEETING**

**UBM1880 + [FINISH]** - Top  
**RNHM1880BLK** - Frame  
 1800 (L) x 800 (W) x 1025 (H)

25mm Top / Round tube frame in black painted finish / Available in CN Exclusive laminates, Anthracite, Stone Grey & White



Images shown for display purposes only. Actual finishes may vary.



LAMINATE FINISHES

-  ACACIA [AC]
-  DARK EUCALYPTUS [DE]
-  NATURAL WALNUT [NW]
-  TAORMINA ASH [TA]
-  TRUE OAK [TO]
-  ANTHRACITE [AN]
-  STONE GREY [SG]
-  WHITE [WH]

**URBAN** HIGH TABLE OFFERS A MODERN AND APPROACHABLE VIBE TO THE WORKPLACE, CREATING THE PERFECT ENVIRONMENT FOR TEAMS TO DO THEIR BEST WORK.

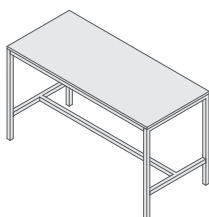

**URBAN HIGH MEETING**

UBM1880 + [FINISH] - Top  
 UBHM1880 + [BLK/SI/WH] - Frame  
 1800 (L) x 800 (W) x 1025 (H)

25mm Top / Available in Black [BLK], Silver [SI] or White [WH] square tube frame / Available in CN Exclusive laminates, Anthracite, Stone Grey & White



**PYLON** IS A SLEEK INDUSTRIAL STYLE MODERN HIGH TABLE. PERFECTLY SUITED TO CANTEEN, COLLABORATION & TRAINING APPLICATIONS.

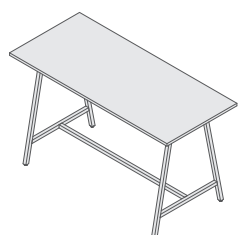

#### **PYLON** MEETING

**UBM1880 + [FINISH]** - Top  
**PYHM1500BLK** - Frame  
1800 (L) x 800 (W) x 1034 (H)

25mm Top / Black square tube frame / Available in  
CN Exclusive laminates, Anthracite, Stone Grey & White



100%  
EXCLUSIVE

**Y-FRAME**, THIS HIGH MEETING TABLE WITH TAPERED OR RECTANGULAR TOP IS IDEAL FOR THOSE MEETINGS WHERE YOU NEED TO INCORPORATE MULTIMEDIA.

### Y-FRAME HIGH MEETING

**RECTANGULAR**  
YFMT2012 + [FINISH] - Top  
YFHM2012 + [BLK/CH/WH] - Frame  
2000 (L) x 1200 (W) x 1022 (H)

22mm Supalam top with reverse chamfered edge / 25 x 60mm Rectangular tube frame available in Black [BLK], Charcoal [CH] or White [WH] / Available in CN Exclusive Supalam finishes, Anthracite & White

**TAPERED**  
YFMT2080 + [FINISH] - Top  
YFHM2080 + [BLK/CH/WH] - Frame  
2000 (L) x 1200 - 800 (W) x 1022 (H)

22mm Supalam top with reverse chamfered edge / 25 x 60mm Rectangular tube frame available in Black [BLK], Charcoal [CH] or White [WH] / Available in CN Exclusive Supalam finishes, Anthracite & White

#### SUPALAM FINISHES

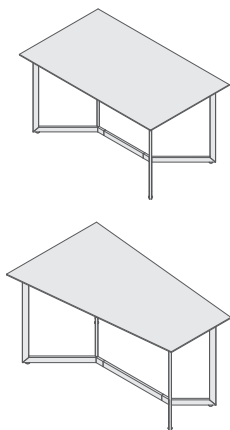





**DIAGONAL STREET**, PERFECT FOR GROUPWORK TRAINING, COMPACT AND EASY TO SET UP AND REARRANGE TO ACCOMMODATE CHANGING NEEDS.

LAMINATE FINISHES



NATURAL WALNUT  
[NW]



ANTHRACITE  
[AN]



WHITE  
[WH]

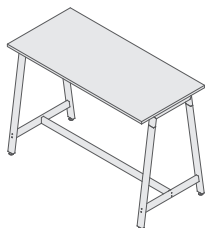

**DIAGONAL STREET HIGH MEETING**

**DSMT1260 + [FINISH]** - Top  
**DSHM1260WD** - White understructure  
**DSHM1260SWD** - Anthracite understructure  
 1200 (L) x 600 (W) x 1025 (H)

25mm Top / 60 x 40mm Solid Oak legs with metal understructure in white or anthracite painted finish / Available in Natural Walnut, Anthracite & White laminates



**PRIME TIME**, AN ENTRY LEVEL PANEL LEG TABLE, OFFERING SIMPLE FUNCTIONALITY IN TWO TRADITIONAL LAMINATE FINISHES.

### **PRIME TIME MEETING**



**PT120 + [FINISH]**  
1200 Ø x 725 (H)

22mm Round top with panel legs / Available in American Walnut & Maple laminates

### **PRIME TIME BOARDROOM 2400**

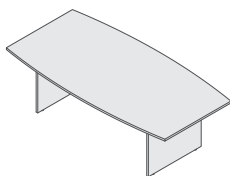

**PT2400 + [FINISH]**  
2400 (L) x 1200 (W) 725 (H)

22mm Barrel top with panel legs including modesty panel / Available in American Walnut & Maple laminates

#### LAMINATE FINISHES

 AMERICAN WALNUT [AWN]

 MAPLE [ML]



**XPRESS**, AN INDUSTRY FAVOURITE FOR ITS SIMPLISTIC DESIGN AND QUICK INSTALLATION TIME. PAIR IT WITH ANTHRACITE TO GIVE THIS TRADITIONAL TABLE A MODERN LOOK.

LAMINATE FINISHES

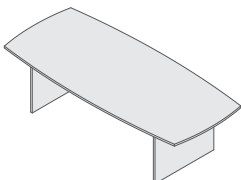
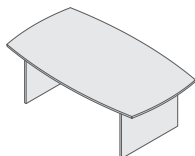

**XPRESS MEETING**

**XP120 + [FINISH]**  
1200 Ø x 725 (H)

25mm Round top with panel legs / Available in CN Exclusive laminates, Stone Grey & White or CN Exclusive laminates paired with anthracite

**XPRESS BOARDROOM 2100**

**XP2100 + [FINISH]**  
2100 (L) x 1200 (W) x 725 (H)

25mm Barrel top with panel legs including modesty panel / Available in CN Exclusive laminates, Stone Grey & White or CN Exclusive laminates paired with anthracite

**XPRESS BOARDROOM 2700**

**XP2700 + [FINISH]**  
2700 (L) x 1200 (W) x 725 (H)

25mm Barrel top with panel legs including modesty panel / Available in CN Exclusive laminates, Stone Grey & White or CN Exclusive laminates paired with anthracite

100%  
EXCLUSIVE



### JENNY MEETING

RDT120 + [FINISH] - Top  
JN700 + [BLK/WH] - Jenny Leg 700 (H)  
1200 Ø x 722 (H)

22mm Supalam top with reverse chamfered edge / Black [BLK] or White [WH] metal legs with tapered solid Oak foot / Available in CN Exclusive Supalam finishes, Anthracite & White

#### SUPALAM FINISHES



ACACIA [AC]



DARK EUCALYPTUS [DE]



NATURAL WALNUT [NW]



TAORMINA ASH [TA]



TRUE OAK [TO]



ANTHRACITE [AN]



WHITE [WH]

### STYLUS MEETING

GT120 + [FINISH] - Top  
STY700 + [BLK/WH] - Stylus Leg 700 (H)  
1200 Ø x 725 (H)

25mm Top / Tapered metal legs, available in Black [BLK] or White [WH] / Available in CN Exclusive laminates, Anthracite, Stone Grey & White



#### LAMINATE FINISHES



ACACIA [AC]



DARK EUCALYPTUS [DE]



NATURAL WALNUT [NW]



TAORMINA ASH [TA]



TRUE OAK [TO]



ANTHRACITE [AN]



STONE GREY [SG]



WHITE [WH]



### FRESCO MEETING

FRM1200 + [FINISH] - Top  
FRSS7012 + [BLK/WH] - Base  
1200 Ø x 735 (H)

25mm Top / 4-Star base available in Black [BLK] or White [WH] painted finish / Clear adjustable ferrules / Available in CN Exclusive laminates, Anthracite, Stone Grey & White



100%  
EXCLUSIVE

WITH A CONTEMPORARY FEEL AND A MODERN AESTHETIC, THE **RADISSON** WITH GLASS OR WOOD TABLETOP WILL COMPLIMENT ALMOST ANY SETTING FROM PRIVATE OFFICES TO EVERY TOUCHDOWN SPACE IN-BETWEEN.



### RADISSON MEETING

**GLASS**  
RDG1200 + [BLK/WH]  
1200 Ø x 730 (H)

10mm Clear toughened glass top / UV bonded to metal base available in Black [BLK] or White [WH] painted finish

**WOOD**  
RDT120 + [FINISH] - Top  
RDB725 + [BLK/WH] - Base 715 (H)  
1200 Ø x 737 (H)

22mm Supalam top with reverse chamfered edge / Metal base available in Black [BLK] or White [WH] painted finish / Available in CN Exclusive Supalam finishes, Anthracite & White

#### SUPALAM FINISHES



NATURAL WALNUT  
[NW]



TRUE OAK  
[TO]



WHITE  
[WH]





100%  
EXCLUSIVE

## SET SQUARE SERVER - 1600W

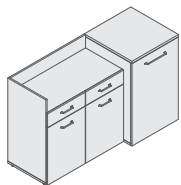

**SSQ1697 + [FINISH]**  
1600 (W) x 620 (D) x 970 (H)  
\*Fits 120l - 130l fridge **[F130]**

3 x Hinge doors & 2 x drawers / Drawer fronts in matching wood grain or paired finish / Available in CN Exclusive laminates or CN Exclusive laminates paired with anthracite, black, stone grey or white



## SET SQUARE SERVER - 1100W

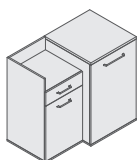

**SSQ1197 + [FINISH]**  
1100 (W) x 620 (D) x 970 (H)  
\*Fits 120l - 130l fridge **[F130]**

2 x Hinge doors & 1 x drawer / Drawer front in matching wood grain or paired finish / Available in CN Exclusive laminates or CN Exclusive laminates paired with anthracite, black, stone grey or white

### LAMINATE FINISHES

- 

ACACIA  
[AC] / [ACA] / [ACS] / [ACW]
- 

DARK EUCALYPTUS  
[DE] / [DEA] / [DEB] / [DEW]
- 

NATURAL WALNUT  
[NW] / [NWA] / [NWB] / [NWW]
- 

TAORMINA ASH  
[TA] / [TAA] / [TAS] / [TAW]
- 

TRUE OAK  
[TO] / [TOA] / [TOB]
- 

ANTHRACITE  
[AN]
- 

BLACK  
[BLK]
- 

STONE GREY  
[SG]
- 

WHITE  
[WH]



100%  
EXCLUSIVE

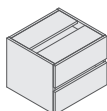
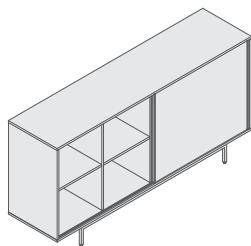

## UNI<sup>Q</sup> SERVER

SERVER UNIT  
**UQ1809 + [FINISH]**  
 1800 (W) x 450 (D) x 900 (H)

Black sliding door / Right side with fixed shelf / Left side with 4 x pigeon holes /  
 Steel frame in black painted finish / Available in CN Exclusive laminates paired with  
 anthracite, black, stone grey or white

MOVABLE PEDESTAL  
**UQ4235 + [FINISH]**  
 428 (W) x 396 (D) x 347 (H)

2 x Standard drawers / Available in CN Exclusive laminates, Anthracite, Black, Stone  
 Grey & White

\*Pedestal fits into all four pigeon hole openings

100%  
EXCLUSIVE

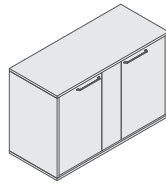

### ECOCENTRIC SERVER

**ECO1490 + [FINISH]**  
1400 (W) x 600 (D) x 949 (H)  
\*Fits 120L - 130L fridge **[F130]**

2 x Hinge doors & concealed wine rack /  
Includes timber shelves / Available in CN  
Exclusive laminates paired with anthracite, black,  
stone grey or white

\*When pairing, door fronts will be in paired finish

#### LAMINATE FINISHES

- 

ACACIA  
[AC] / [ACA] / [ACB] / [ACS] / [ACW]
- 

DARK EUCALYPTUS  
[DE] / [DEA] / [DEB] / [DEW]
- 

NATURAL WALNUT  
[NW] / [NWA] / [NWB] / [NWW]
- 

TAORMINA ASH  
[TA] / [TAA] / [TAB] / [TAS] / [TAW]
- 

TRUE OAK  
[TO] / [TOA] / [TOB] / [TOW]



### BRAINSTORM SERVERS

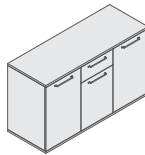

**EV1609A + [FINISH]**  
1600 (W) x 600 (D) x 933 (H)  
\*Fits 120L - 130L fridge **[F130]**

3 x Hinge doors & 1 x drawer / Available in CN  
Exclusive laminates, Anthracite, Stone Grey & White

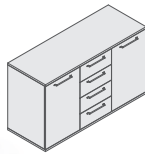

**EV1609B + [FINISH]**  
1600 (W) x 600 (D) x 933 (H)  
\*Fits 120L - 130L fridge **[F130]**

2 x Hinge doors & 4 x drawers / Available in CN  
Exclusive laminates, Anthracite, Stone Grey & White

#### LAMINATE FINISHES

- 

ACACIA  
[AC]
- 

DARK EUCALYPTUS  
[DE]
- 

NATURAL WALNUT  
[NW]
- 

TAORMINA ASH  
[TA]
- 

TRUE OAK  
[TO]
- 

ANTHRACITE  
[AN]
- 

STONE GREY  
[SG]
- 

WHITE  
[WH]







## MOBI SERVER

**MBS1390 + [B/W] + [FINISH]**  
1300 (W) x 600 (D) x 900 (H)

16mm top with rounded corners / 2 x Hinge doors with Black [B] or White [W] finger grip handles / 1 x Internal drawer & 2 x open compartments / Available in CN Exclusive laminates, Anthracite, Stone Grey & White

100%  
EXCLUSIVE

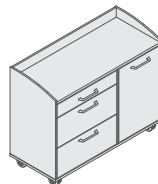

## ESPRESSO SERVER

**EV1409 + [FINISH]**  
1400 (W) x 600 (D) x 1122 (H)  
\*Fits 120L - 130L fridge **[F130]**

1 x Hinge door, 1 x standard drawer & 2 x deep drawers / Available in CN Exclusive laminates, Anthracite, Stone Grey & White

Images shown for display purposes only. Actual finishes may vary.





TRAINING



100%  
EXCLUSIVE

**SLIM**, A FLEXIBLE SOLUTION FOR CONFERENCE ROOMS, MEETING AREAS AND TRAINING FACILITIES. EQUIPPED WITH LOCKABLE CASTORS & FLIP-TOP MECHANISM, THIS TABLE CAN BE EASILY MOVED AND CONVENIENTLY NESTED.





LAMINATE FINISHES



ACACIA  
[AC]



DARK EUCALYPTUS  
[DE]



NATURAL WALNUT  
[NW]



TAORMINA ASH  
[TA]



TRUE OAK  
[TO]



ANTHRACITE  
[AN]



STONE GREY  
[SG]



WHITE  
[WH]



**SLIM NESTING TABLES**

1800 (L)  
**SL1800B + [FINISH]** - Black leg  
**SL1800 + [FINISH]** - White leg  
 1800 (L) x 750 (W) x 725 (H)

1400 (L)  
**SL1400B + [FINISH]** - Black leg  
**SL1400 + [FINISH]** - White leg  
 1400 (L) x 750 (W) x 725 (H)

25mm Top / Black or white painted legs / Lockable castors / Available in CN Exclusive laminates, Anthracite, Stone Grey & White



100%  
EXCLUSIVE

**DOMINO**, THE PERFECT TABLE TO ARRANGE AND REARRANGE IN MULTI-FUNCTIONAL SPACES. EQUIPPED WITH A FUNCTIONAL LINKING DEVICE, ENABLING MULTIPLE CONFIGURATIONS.



LAMINATE FINISHES

ACACIA  
[AC]

DARK EUCALYPTUS  
[DE]

NATURAL WALNUT  
[NW]

TAORMINA ASH  
[TA]

TRUE OAK  
[TO]

ANTHRACITE  
[AN]

STONE GREY  
[SG]

WHITE  
[WH]

**DOMINO NESTING TABLES**

1800 (L)  
**DM1800 + [FINISH]**  
1800 (L) x 750 (W) x 725 (H)

1400 (L)  
**DM1400 + [FINISH]**  
1400 (L) x 750 (W) x 725 (H)

25mm Top / Silver painted legs / Lockable castors / Available in CN Exclusive laminates, Anthracite, Stone Grey & White



**TEKNO**, IS A MULTI-FUNCTION TABLE THAT RESPONDS TO THE NEEDS OF A DYNAMIC WORKING SPACE. WITH ITS AESTHETIC AND FUNCTIONAL ADVANTAGES HOUSED IN AN ELEGANT STRUCTURE WITH ALUMINIUM DIE-CAST FEET AND 75mm CASTORS.



**TEKNO NESTING TABLES**

1800 (L)  
**TK1800 + [FINISH]**  
 1800 (L) x 750 (W) x 725 (H)

1400 (L)  
**TK1400 + [FINISH]**  
 1400 (L) x 750 (W) x 725 (H)

25mm Top / Black painted legs / Lockable castors / Available in CN Exclusive laminates, Anthracite, Stone Grey & White

Images shown for display purposes only. Actual finishes may vary.



100%  
EXCLUSIVE

**A-LINE**, WITH ITS HANDY AND PRACTICAL FOLDING LEGS DESIGNED FOR MULTI-FUNCTION ENVIRONMENTS, WHERE FREQUENT CHANGES IN LAYOUT AND ORGANISATION ARE REQUIRED.



LAMINATE FINISHES

ACACIA  
[AC]

DARK EUCALYPTUS  
[DE]

NATURAL WALNUT  
[NW]

TAORMINA ASH  
[TA]

TRUE OAK  
[TO]

ANTHRACITE  
[AN]

STONE GREY  
[SG]

WHITE  
[WH]

### **A-LINE** NESTING TABLES

750 (W)  
**AF750 + [FINISH]**  
1800 (L) x 750 (W) x 745 (H)

450 (W)  
**AF450 + [FINISH]**  
1800 (L) x 450 (W) x 745 (H)

25mm Top with stiffening bars / Black painted legs / Stackable when folded / Available in CN Exclusive laminates, Anthracite, Stone Grey & White





THE **ACHIEVER** FEATURES A CLOSURE SYSTEM ENTIRELY IN STEEL, EQUIPPED WITH SPECIAL RUBBER SUPPORTS THAT PREVENT THE MOVEMENT OF THE TABLES WHEN THEY ARE STACKED.

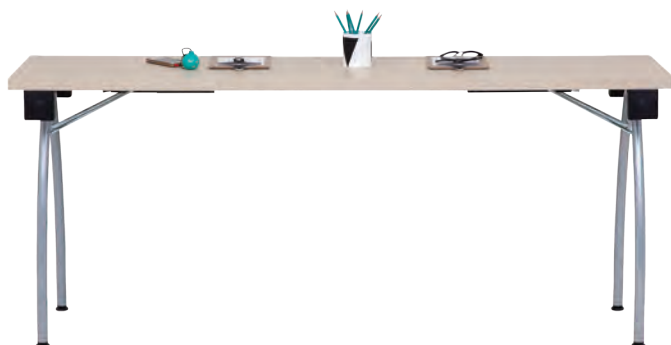

### **ACHIEVER** NESTING TABLES

750 (W)  
**AC750 + [FINISH]**  
 1800 (L) x 750 (W) x 745 (H)

450 (W)  
**AC450 + [FINISH]**  
 1800 (L) x 450 (W) x 745 (H)

25mm Top with stiffening bars / Silver painted legs / Stackable when folded / Available in CN Exclusive laminates, Anthracite, Stone Grey & White



100%  
EXCLUSIVE



LAMINATE FINISHES

BARREL OAK  
[BO]

FOLKSTONE GREY  
[FG]

MONDEGO ELM  
[ME]

WHITE  
[WH]

**BREAKING NEWS TABLES**

**BN1800 + [BLK/LGR/SI/WH] + [FINISH]**  
1800 (L) x 450 (W) x 716 (H)

**BN750 + [BLK/LGR/SI/WH] + [FINISH]**  
750 (L) x 500 (W) x 716 (H)

16mm Top including modesty panel / 32 x 32mm Metal frame in Black [BLK], Light Grey [LGR], Silver [SI] or White [WH] painted finish / Available in Barrel Oak, Folkstone Grey, Mondego Elm & White laminates



## CONFERENCE FOLDING TABLES

750 (W)  
**CFT1875 + [BLK/LGR/SI/WH] + [FINISH]**  
 1800 (L) x 750 (W) x 722 (H) x 22mm

450 (W)  
**CFT1845 + [BLK/LGR/SI/WH] + [FINISH]**  
 1800 (L) x 450 (W) x 716 (H) x 16mm

600 (W)  
**CFT1350 + [BLK/LGR/SI/WH] + [FINISH]**  
 1350 (L) x 600 (W) x 716 (H) x 16mm

16mm or 22mm Top / Spring-loaded 50 x 25mm metal frame in Black [BLK], Light Grey [LGR], Silver [SI] or White [WH] painted finish / Bumper spacer for stacking / Available in Barrel Oak, Folkstone Grey, Mondego Elm & White laminates



## SNAP NESTING TABLES

**SN1350 + [B/W] + [FINISH]**  
 1350 (L) x 600 (W) x 716 (H) x 16mm  
**SN1500 + [B/W] + [FINISH]**  
 1500 (L) x 600 (W) x 722 (H) x 22mm  
**SN1800 + [B/W] + [FINISH]**  
 1800 (L) x 600 (W) x 722 (H) x 22mm

16mm or 22mm Top / Metal frame with easy flip top mechanism available in Black [B] or White [W] painted finish / Lockable castors / Available in Barrel Oak, Folkstone Grey, Mondego Elm & White laminates



### CLASS ACT TABLES

RECTANGULAR  
**CA1370R + [BLK/LGR/SI/WH] + [FINISH]**  
 1370 (L) x 685 (W) x 726 (H)



TRAPEZOID  
**CA1370T + [BLK/LGR/SI/WH] + [FINISH]**  
 1370 - 685 (L) x 685 (W) x 726 (H)

16mm Top / Metal frame in Black [BLK], Light Grey [LGR], Silver [SI] or White [WH] painted finish / Available in Barrel Oak, Folkstone Grey, Mondego Elm & White laminates

#### LAMINATE FINISHES



BARREL OAK  
[BO]



FOLKSTONE GREY  
[FG]



MONDEGO ELM  
[ME]



WHITE  
[WH]

#### POSSIBLE CONFIGURATIONS:

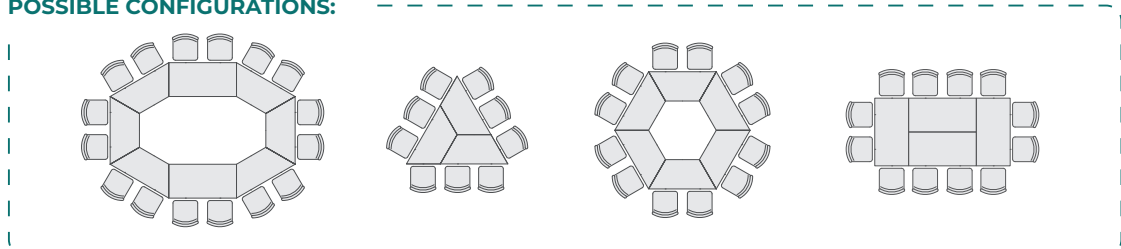



### **BANQUET** ROUND TABLE

**BTE1800WH**  
1800 Ø x 716 (H)

16mm Top with black rubberised knock-in edge / Black painted folding frame / Available in White laminate



**FOLD-IT** TABLE, A SPACE SAVING TABLE THAT CAN FOLD, PERFECT FOR MEETINGS, WORKGROUPS & BANQUETS. ONCE CLOSED IT CAN PASS WITH EASE THROUGH DOORS AND ELEVATORS AND CAN BE EASILY STORED AWAY.

### **FOLD-IT** TABLE

**FD1800WH**  
1800 Ø x 760 (H)

22mm Top with black bumper edging / White painted folding frame / Lockable castors when folded / Static feet when open / Easy fold-up mechanism / Available in White laminate





**RONDO**, IS AN ECONOMIC SOLUTION FOR TRADITIONAL AND COLLABORATIVE CLASSROOMS MAKING IT A TIMELESS FAVOURITE.



### **RONDO TABLES**

**RNF1400 + [BLK/SI/WH]** - Frame  
**RNT1475 + [FINISH]** - Top  
 1400 (L) x 750 (W) x 740 (H)

**RNF1800 + [BLK/SI/WH]** - Frame  
**RNT1875 + [FINISH]** - Top  
 1800 (L) x 750 (W) x 740 (H)

25mm Top / Round tube metal frame in Black [BLK], Silver [SI] or [WH] painted finish / Available in CN  
 Exclusive laminates, Anthracite, Stone Grey & White

#### LAMINATE FINISHES



ACACIA  
[AC]



DARK EUCALYPTUS  
[DE]



NATURAL WALNUT  
[NW]



TAORMINA ASH  
[TA]



TRUE OAK  
[TO]



ANTHRACITE  
[AN]



STONE GREY  
[SG]



WHITE  
[WH]



**LA KENDO**, IS A FLEXIBLE AND SPACE-SAVING SOLUTION THAT CAN BE EASILY MOVED AND CONVENIENTLY NESTED. EQUIPPED WITH TWO ELEGANTLY SHAPED CASTORS, A FLIP TOP MECHANISM AND A COMPACT TABLETOP.



### **LA KENDO** NESTING TABLES

**LKF6073 + [BLK]** - Frame  
**LKT6050 + [FINISH]** - Top  
600 (L) x 500 (W) x 746 (H)

16mm Top / Black painted frame and modesty panel / Castors on front legs for easy movement / Available in CN Exclusive laminates, Anthracite, Stone Grey & White

100%  
EXCLUSIVE

**ICON**, WITH IT'S SIMPLE AND ELEGANT DESIGN THIS CHAIR FITS INTO MOST OFFICE SPACE ENVIRONMENTS.



Built-in linking bracket for connecting chairs together

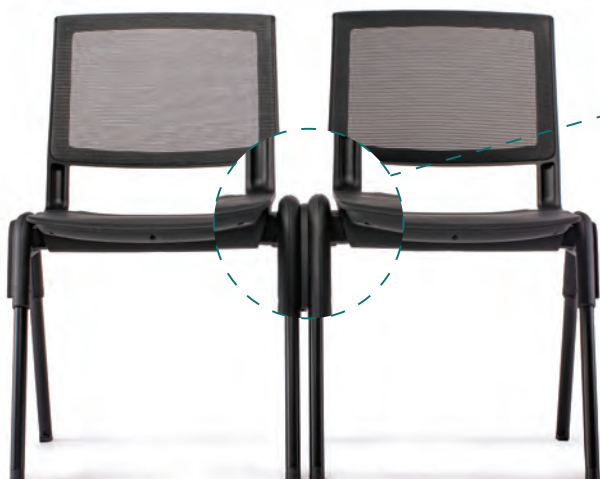

### **ICON CHAIR**

**IC06BLK**  
**ICWTBLK** - Optional Writing Tablet

Black painted 4-legged frame / Black polypropylene seat with black mesh back / Optional right handed black polypropylene writing tablet with metal arm / Stackable without writing table

*Stackable : Chairs stack 12 high / Writing tablet holds up to 20kg*

The **ICON** chair meets the following international standards : **BIFMA & GREENGUARD GOLD.**

Images shown for display purposes only. Actual finishes may vary.



100%  
EXCLUSIVE



## LIBRA 4-LEGGED

LB06 + [BLK/WH]

Polypropylene seat & back / Matching 4-legged frame /  
Stackable / Available in Black [BLK] or White [WH]

*Stackable : Chairs stack 15 high*



## LIBRA SLEIGH

LBS06 + [BLK/WH]

Polypropylene seat & back / Matching sleigh frame / Stackable /  
Available in Black [BLK] or White [WH]

*Stackable : Chairs stack 15 high*



**FREE REIN** IS VERSATILE IN ITS SIMPLICITY, OFFERS COMFORT WHILE BLENDING INTO A WIDE RANGE OF WORKSPACES.



### **FREE REIN NESTING CHAIR**

**FRE06BLK**

Black & White striped mesh backrest / Sliding arms / Ergonomic tilting backrest / Moulded foam seat / Silver painted frame with hidden castors on rear legs / Standard black upholstery



**FREL - Free Rein Linking Bracket**

Links Free Rein nesting armchairs via the back legs / Eliminates movement / Available in black

The **FREE REIN** chair meets the following international standard : **BIFMA & GREENGUARD Certified.**

Images shown for display purposes only. Actual finishes may vary.



**LA'KENDO** IS DESIGNED TO OFFER AN ADAPTABLE SEAT FOR MULTIFUNCTIONAL USES, PERFECTLY VERSATILE FOR MEETING, TRAINING AND COLLABORATIVE SPACES WITH A HIGH LEVEL OF COMFORT AND ERGONOMIC PARAMETERS.



**LA'KENDO**

SIDE CHAIR  
**LK06GR**  
**LK06GR + [COM]**

Grey polypropylene seat & back / Aluminium painted frame / Stackable / Optional seat upholstered in [COM]

\*Fabric requirements : 0,6m seat upholstery

Stackable : Chairs stack 20 high

ARMCHAIR  
**LKA06GR**  
**LKA06GR + [COM]**

Grey polypropylene seat & back / Aluminium painted frame / Stackable / Optional seat upholstered in [COM]

\*Fabric requirements : 0,6m seat upholstery

ARMCHAIR WITH WRITING TABLET  
**LKA06TGR**  
**LKA06TGR + [COM]**

Grey polypropylene seat & back / Aluminium painted frame / Stackable / Black writing tablet fits to right hand of armchair / Optional seat upholstered in [COM]

\*Fabric requirements : 0,6m seat upholstery



**LA'KENDO**

SIDE CHAIR ON CASTORS  
**LK06CBLK**  
**LK06CBLK + [COM]**

Thermo-injected polypropylene seat & back / Matching integrated frame with 50mm castors / Available in Black [BLK] / Optional seat upholstered in [COM]

\*Fabric requirements : 0,6m seat upholstery

Stackable : Chairs stack 20 high



ARMCHAIR ON CASTORS  
**LKA06C + [BLK/GR]**  
**LKA06C + [BLK/GR] + [COM]**

Thermo-injected polypropylene seat & back / Matching integrated frame with 50mm castors / Available in Black [BLK] or grey [GR] / Optional seat upholstered in [COM]

\*Fabric requirements : 0,6m seat upholstery

The LA'KENDO chairs meet the following international standards : CATAS Certified.

Images shown for display purposes only. Actual finishes may vary.



100%  
EXCLUSIVE



**ECLIPSE** WITH ITS CONTINUOUS CURVED LINE, GENERATING A CLEAN AND ESSENTIAL SEAT, WHICH CONVEYS LIGHTNESS.



COLOURS



ANTHRACITE  
[AN]



ANTIQUÉ ROSE  
[AR]



LIGHT GREY  
[GR]



MINT  
[MT]



RUST  
[RS]



WHITE  
[WH]



**ECLIPSE SLEIGH**

BLACK FRAME  
ECB06 + [COLOUR]  
ECBSU06 + [COLOUR] + [COM] - Upholstered seat

CHROME FRAME  
EC06 + [COLOUR]  
ECSU06 + [COLOUR] + [COM] - Upholstered seat

Fibreglass-reinforced polypropylene shell / Sleigh frame in black or chrome / Optional seat upholstered in [COM] / Available in anthracite, antique rose, light grey, mint, rust or white

\*Fabric requirements : 0,6m seat upholstery (0,6m for 2 x seats)

The **ECLIPSE** chairs meet the following international standards : CATAS Certified.

Images shown for display purposes only. Actual finishes may vary.



**LA'FILO**, AN ELEGANT AND COLOURFUL CHAIR OFFERING VERSATILITY AND LIGHTNESS WITH A MINIMALIST DESIGN.

LA'FILO COLOURS



BLACK  
[BLK]



BLUE  
[BL]



GREY  
[GR]



SAND  
[SD]



WHITE  
[WH]



### LA'FILO CHAIRS

ARMCHAIR WITH WRITING TABLET - BLACK FRAME  
LFA06BT + [COLOUR]  
LFAU06BT + [COLOUR] + [COM]

ARMCHAIR WITH WRITING TABLET - CHROME FRAME  
LFA06BT + [COLOUR]  
LFAU06BT + [COLOUR] + [COM]

ARMCHAIR - BLACK FRAME  
LFA06B + [COLOUR]  
LFAU06B + [COLOUR] + [COM]

ARMCHAIR - CHROME FRAME  
LFA06 + [COLOUR]  
LFAU06 + [COLOUR] + [COM]

SIDE CHAIR - BLACK FRAME  
LF06B + [COLOUR]  
LFU06B + [COLOUR] + [COM]

SIDE CHAIR - CHROME FRAME  
LF06 + [COLOUR]  
LFU06 + [COLOUR] + [COM]

Black or chrome sleigh frame with polypropylene seat & back / With or without arms / Armchair with writing tablet, includes 1 x right handed white high pressure laminate writing tablet / Stackable / Optional seat & back upholstered in [COM] / Available in black, blue, grey, sand or white

\*Fabric requirements : 1,1m seat & back upholstery

Stackable : Armchairs & side chairs stack 15 high



The LA'FILO chairs meet the following international standards : CATAS Certified.

Images shown for display purposes only. Actual finishes may vary.



### LA'MIA SIDE CHAIRS

LM06 + [COLOUR]  
LM06 + [COLOUR] + [COM] - Upholstered seat

Polypropylene seat & back / Matching 4-legged frame / Stackable / Available in black, grey or white

\*Fabric requirements : 0,7m seat upholstery (0,7m for 2 x seats)

Stackable : Side chairs stack 20 high

#### OPTIMAL WRITING TABLET:

- LMWT + [BLK/GR/WH]  
Includes 1 x right hand arm in black, grey or white painted finish with polypropylene arm cap / White armchair has grey polypropylene arm cap



### LA'MIA ARMCHAIR

LMA06 + [COLOUR]  
LMA06 + [COLOUR] + [COM] - Upholstered seat

Polypropylene seat, back & armcaps / Matching 4-legged frame with arms / Stackable / Available in black, grey or white

\*Fabric requirements : 0,7m seat upholstery (0,7m for 2 x seats)

Stackable : Armchairs stack 20 high

#### LA'MIA COLOURS



BLACK  
[BBLK]



GREY  
[GR]



WHITE  
[WWH]

The LA'MIA chairs meet the following international standards : CATAS Certified.

Images shown for display purposes only. Actual finishes may vary.



## MULTI CHAIRS

ARMCHAIR  
MLTA06BLK  
MLTASU06BLK + [COM] - Upholstered seat  
MLTAU06BLK + [COM] - Upholstered seat & back

SIDE CHAIR  
MLT06BLK  
MLTSU06BLK + [COM] - Upholstered seat  
MLTU06BLK + [COM] - Upholstered seat & back

Black polypropylene seat, back & arms / Matching black painted frame / Stackable / Optional upholstered seat or seat & back in [COM]

\*Fabric requirements : 0,7m seat upholstery (0,7m for 2 x seats) 0,7m seat & back upholstery

Stackable : Armchairs & side chairs stack 6 high



## VOLÉE CHAIRS

ARMCHAIR - BLACK FRAME  
VOLA06BLK  
VOLASU06BLK + [COM] - Upholstered seat

SIDE CHAIR - BLACK FRAME  
VOL06BLK  
VOLSU06BLK + [COM] - Upholstered seat

ARMCHAIR - GREY FRAME  
VOLA06GR  
VOLASU06GR + [COM] - Upholstered seat

SIDE CHAIR - GREY FRAME  
VOL06GR  
VOLSU06GR + [COM] - Upholstered seat

Black or grey mesh back with black or grey polypropylene seat / With or without arms / Matching painted frame / Stackable / Optional upholstered seat in [COM]

\*Fabric requirements : 0,6m seat upholstery (0,6m for 2 x seats)

Stackable : Arm chairs & side chairs stack 20 high

The VOLÉE chairs meet the following international standards : CATAS Certified.

Images shown for display purposes only. Actual finishes may vary.





LAMINATE FINISHES



**RICKSTACKER CHAIRS**

RS13 + [FABRIC]

RS15 + [FABRIC] - Chair with writing tablet

\*Laminate colour to be specified on order

Black painted 4-legged frame / Stackable / Side chair with writing tablet includes 1 x right handed writing tablet: available in Barrel Oak, Folkstone Grey, Mondego Elm & White laminates / Upholstered in Contract Black or [COM]

\*Fabric requirements : 0,5m seat upholstery (0,4m seat upholstery) (0,4m back upholstery)



FABRIC



CONTRACT BLACK [BLK]



CUSTOMERS OWN MATERIAL [COM]

**BANQUET SIDE CHAIR**

BT06 + [FABRIC]

Black painted 4-legged frame / Stackable / Upholstered in Contract Black or [COM]

\*Fabric requirements : 0,85m upholstery (0,5m seat upholstery) (0,6m back upholstery)



**ETERNITY SIDE CHAIR**

ET06BLK

Black polypropylene outer seat & back cover / Black painted 4-legged frame / Upholstered in standard black fabric / Stackable

Stackable : Chairs stack 10 high



**RELOAD SIDE CHAIR**

RL06BLK

Black polypropylene outer seat & back rest / Black painted 4-legged frame / Upholstered seat in standard black fabric / Stackable

Stackable : Chairs stack 10 high



**VARSIITY**, THIS HIGHLY MOBILE SEATING IS NOT ONLY SUITABLE FOR INDIVIDUAL LEARNING, BUT ALSO FOR GROUP COLLABORATION AND SHARING OF IDEAS.



#### **VARSIITY STUDENT**

Polypropylene shell / Black painted base on castors with black polypropylene storage tray / Large writing tablet, 360° rotating / Independent cup holder / Optional seat upholstery in standard grey or orange fabric / Available in Dark Grey, Green, Light Grey or Orange

The **VARSIITY** chair meets the following international standard : **BIFMA & GREENGUARD Certified**.

Images shown for display purposes only. Actual finishes may vary.



DARK GREY



LIGHT GREY



GREEN



ORANGE



SPECIAL IMPORT: Enquire about stock & import lead times.

Images shown for display purposes only. Actual finishes may vary.



**COLLEGE**, A MODEL ADAPTED TO MEET A NEED IN CLASSROOMS AND TRAINING ROOMS. HIGH STABILITY WRITING TABLET WITH 360° SWIVEL AND 4-SPOKE BASE WITH A PRACTICAL SLIDE.



COLOURS

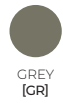

**COLLEGE STUDENT**

Swivel 4-legged base with storage basket in Grey RAL 7040 / Writing tablet in polyurethane with laminate surface / Dedicated steel support arm allows you to rotate the tablet 360 degrees / Shell available in blue, green, grey, lemon yellow, orange or red



**SPECIAL IMPORT:** Enquire about stock & import lead times.

The COLLEGE chair meets the following international standards : **CATAS Certified.**

Images shown for display purposes only. Actual finishes may vary.

**ACE**, THIS HIGHLY MOBILE SEATING IS NOT ONLY SUITABLE FOR INDIVIDUAL LEARNING, BUT ALSO FOR GROUP COLLABORATION AND SHARING OF IDEAS.



### ACE STUDENT

Black polypropylene shell / Black painted base on castors with black polypropylene storage tray / Large writing tablet, 360° rotating / Independent cup holder / Upholstery in standard dark grey fabric



**SPECIAL IMPORT:** Enquire about stock & import lead times.

The ACE chair meets the following international standard : BIFMA & GREENGUARD Certified.

Images shown for display purposes only. Actual finishes may vary.





# CANTEEN



The BIT chair meets the following international standard : **CATAS Certified**.

Images shown for display purposes only. Actual finishes may vary.





**BIT**, REFINED DESIGN AND ATTENTION TO DETAIL. ITS PERFORATION PATTERN AND RANGE OF COLOURS MAKE BIT SUITABLE FOR INDOOR & OUTDOOR USE.



ANTHRACITE  
[AN]



CORAL  
[CR]



MUSTARD  
[MT]



TURQUOISE  
[TQ]

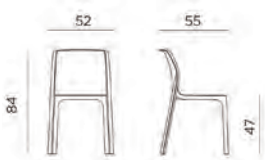

### **BIT** SIDE CHAIR

BT06 + [COLOUR]

Monobloc stackable chair in fibreglass reinforced polypropylene / UV Resistant / Recyclable resin / Non-slip feet / Matt finish / Available in anthracite, coral, mustard or turquoise





**BIT**, DECORATED WITH THE UNIQUE SQUARE PERFORATION PATTERN THAT CHARACTERISES THIS RANGE. FLUID & CLEAN LINES ADD TO ITS ELEGANT VERSATILITY.



ANTHRACITE  
[AN]



CORAL  
[CR]



MUSTARD  
[MT]



TURQUOISE  
[TQ]

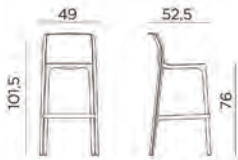

### BIT BARSTOOL

BT07 + [COLOUR]

Monobloc stackable barstool in fibreglass reinforced polypropylene / UV Resistant / Recyclable resin / Non-slip feet / Matt finish / Available in anthracite, coral, mustard or turquoise



ANTHRACITE  
[AN]



CORAL  
[CR]



MUSTARD  
[MT]



TURQUOISE  
[TQ]

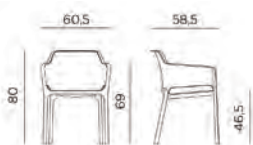

### BIT ARMCHAIR

BTA06 + [COLOUR]

Monobloc stackable armchair in fibreglass reinforced polypropylene / UV Resistant / Recyclable resin / Non-slip feet / Matt finish / Available in anthracite, coral, mustard or turquoise

The **BIT** barstool & armchair meet the following international standard : **CATAS Certified**.

Images shown for display purposes only. Actual finished may vary.



**DOGA**, A RELAXING LARGE LOW ARMCHAIR FOR OUTDOOR USE. FEATURING AN INTERPLAY OF OPEN AND CLOSED SPACES.



ANTHRACITE  
[AN]



MINT  
[MT]



PEAR GREEN  
[GRN]



MARSALA  
[MR]



### DOGA TABLE

DG500 + [COLOUR]

Monobloc side table in fibreglass reinforced polypropylene / UV Resistant / Recyclable resin / Non-slip feet / Matt finish / Available in anthracite, mint, pear green or marsala



ANTHRACITE  
[AN]



MINT  
[MT]



PEAR GREEN  
[GRN]



MARSALA  
[MR]

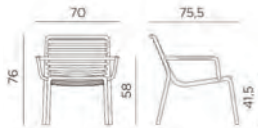

### DOGA RELAX

DGR01 + [COLOUR]

Monobloc stackable armchair in fibreglass reinforced polypropylene / UV Resistant / Recyclable resin / Non-slip feet / Matt finish / Available in anthracite, mint, pear green or marsala



ANTHRACITE  
[AN]



MINT  
[MT]



PEAR GREEN  
[GRN]



MARSALA  
[MR]

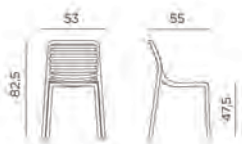

### DOGA SIDE CHAIR

DG06 + [COLOUR]

Monobloc stackable chair in fibreglass reinforced polypropylene / UV Resistant / Recyclable resin / Non-slip feet / Matt finish / Available in anthracite, mint, pear green or marsala

The DOGA Table, Relax and Chair meet the following international standard : CATAS Certified.

Images shown for display purposes only. Actual finishes may vary.



**COSTA**, ESSENTIAL LINES FOR A LIGHTWEIGHT, PRACTICAL AND COMFORTABLE SEAT. A SEAMLESS TUBULAR FRAME WITH ROUNDED PROFILE AND CORNERS.



ANTHRACITE  
[AN]



ICE BLUE  
[BL]



MOSS  
[MS]



RED  
[RD]



WHITE  
[WH]

### COSTA SIDE CHAIR

CS06 + [COLOUR]

Monobloc stackable chair in fibreglass reinforced polypropylene / UV Resistant / Recyclable resin / Non-slip feet / Matt finish / Available in anthracite, ice blue, moss, red or white

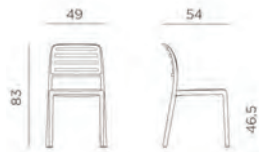

ANTHRACITE  
[AN]



ICE BLUE  
[BL]



MOSS  
[MS]



RED  
[RD]



WHITE  
[WH]

### RIVA SIDE CHAIR

RV06 + [COLOUR]

Monobloc stackable chair in fibreglass reinforced polypropylene / UV resistant / Stackable / Non-slip feet / Matt finish / Available in anthracite, ice blue, moss, red or white

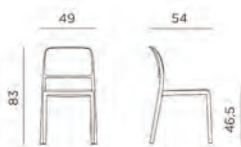



**FARO**, SEAMLESS TUBULAR FRAME AND GENEROUS SIZE. LIGHTWEIGHT AND STACKABLE, MAKING THIS SINGLE BODY STOOL PERFECT FOR OUTDOOR USE.



ANTHRACITE  
[AN]



ICE BLUE  
[BL]



MOSS  
[MS]



RED  
[RD]



WHITE  
[WH]

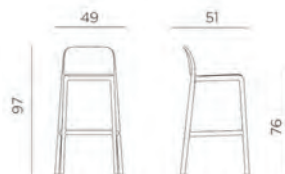

## FARO BARSTOOL

FA07 + [COLOUR]

Monobloc stackable barstool in fibreglass reinforced polypropylene / UV Resistant / Recyclable resin / Non-slip feet / Matt finish / Available in anthracite, ice blue, moss, red or white

The FARO barstool meets the following international standard : **CATAS Certified**.

Images shown for display purposes only. Actual finishes may vary.







**TRILL**, A FIBREGLASS RESIN CHAIR, WITH A HARMONIOUSLY SCULPTURAL, TIMELESS DESIGN. A PRACTICAL CHOICE FOR BOTH INDOOR AND OUTDOOR USE.



ANTHRACITE  
[AN]



MOSS  
[MS]



MUSTARD  
[MT]



OCEAN  
[OC]



TOBACCO  
[TB]

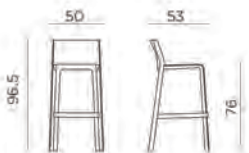

### TRILL BARSTOOL

TRL07 + [COLOUR]

Monobloc stackable barstool in fibreglass reinforced polypropylene / UV Resistant / Recyclable resin / Non-slip feet / Matt finish / Available in anthracite, moss, mustard, ocean or tobacco



ANTHRACITE  
[AN]



MOSS  
[MS]



MUSTARD  
[MT]



OCEAN  
[OC]



TOBACCO  
[TB]

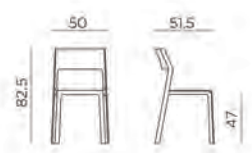

### TRILL SIDE CHAIR

TRL06 + [COLOUR]

Monobloc stackable chair in fibreglass reinforced polypropylene / UV Resistant / Recyclable resin / Non-slip feet / Matt finish / Available in anthracite, moss, mustard, ocean or tobacco



**MAKE-UP** ADAPTS TO DIFFERENT FUNCTIONAL AND STYLISTIC NEEDS, BRINGING BEAUTY TO EVERY SPACE.



BLUE  
[BL]



LIGHT GREY  
[GR]



YELLOW  
[YL]



## **MAKE-UP**

**MK06 + [COLOUR]** - Chair  
**MK07 + [COLOUR]** - Barstool

Metal 4-legged frame with polypropylene seat & back / Stackable / Available in blue, light grey, or yellow

\*(Other colours available on request through special import)

The **MAKE-UP** chair & barstool meet the following international standard : **CATAS Certified**.

Images shown for display purposes only. Actual finishes may vary.

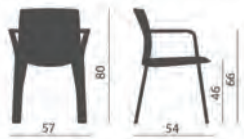

## KLIA ARMCHAIR

### KLIA06 + [COLOUR]

Polypropylene injected UNI-shell using air moulding technology / Stackable / Available in slate grey, turquoise, yellow or white

\*(Other colours available on request through special import)



WHITE  
[WH]



SLATE GREY  
[SGR]



YELLOW  
[YL]



TURQUOISE  
[TQ]

The KLIA armchair meets the following international standard : CATAS Certified.

Images shown for display purposes only. Actual finishes may vary.

100%  
EXCLUSIVE



WHITE  
[WH]



TURQUOISE  
[TQ]



RED  
[RD]



LAVA  
[LV]



GREEN  
[GRN]

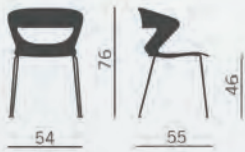

## KICCA ONE

KC106 + [COLOUR]

Monobloc stackable chair in fibreglass reinforced polypropylene / UV Resistant / Available in green, lava, red, turquoise or white



**KICCA**, IS CHEERFUL AND COMFORTABLE WITH A SIMPLE SILHOUETTE AND BRIGHT COLOURS DESIGNED TO BE SOCIAL.

KICCA COLOURS



ANTHRACITE  
[AN]



BLACK  
[BLK]



BLUE  
[BL]



GREEN  
[GRN]



ORANGE  
[OR]



SAND  
[SD]



TURQUOISE  
[TQ]



WHITE  
[WH]



**KICCA WOOD**

KCWD06 + [COLOUR]

KCWDSU06 + [COLOUR] + [COM] - Upholstered seat pad

KCWDU06 + [COLOUR] + [COM] - Upholstered inner shell

Polypropylene shell / Chrome frame with solid wood legs / Optional seat pad or inner shell upholstered in [COM] / Available in anthracite, black, blue, green, orange, sand, turquoise or white

\*Fabric requirements : 0,6m seat upholstery (0,6m for 2 x seats) / 1,1m inner shell upholstery

The KICCA WOOD chair meets the following international standards : CATAS Certified.

Images shown for display purposes only. Actual finishes may vary.

100%  
EXCLUSIVE

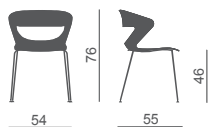

### KICCA 4-LEGGED CHAIR

#### BLACK FRAME

KCB06 + [COLOUR]

KCBSU06 + [COLOUR] + [COM] - Upholstered seat pad

KCBU06 + [COLOUR] + [COM] - Upholstered inner shell

#### CHROME FRAME

KC06 + [COLOUR]

KCSU06 + [COLOUR] + [COM] - Upholstered seat pad

KCU06 + [COLOUR] + [COM] - Upholstered inner shell

#### WHITE FRAME

KCW06 + [COLOUR]

KCWSU06 + [COLOUR] + [COM] - Upholstered seat pad

KCWU06 + [COLOUR] + [COM] - Upholstered inner shell

Polypropylene shell / 4-Legged frame in black, chrome & white / Optional seat pad or inner shell upholstered in [COM] / Available in anthracite, black, blue, green, orange, sand, turquoise or white

\*Fabric requirements : 0,6m seat upholstery (0,6m for 2 x seats) / 1,1m inner shell upholstery

#### KICCA COLOURS



The KICCA chairs meet the following international standards : **CATAS Certified**.

Images shown for display purposes only. Actual finishes may vary.

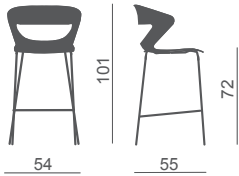

### KICCA 4-LEGGED BARSTOOL

#### BLACK FRAME

KCB07 + [COLOUR]

KCLBSU07 + [COLOUR] + [COM] - Upholstered seat pad

KCBU07 + [COLOUR] + [COM] - Upholstered inner shell

#### CHROME FRAME

KC07 + [COLOUR]

KCLSU07 + [COLOUR] + [COM] - Upholstered seat pad

KCU07 + [COLOUR] + [COM] - Upholstered inner shell

#### WHITE FRAME

KCW07 + [COLOUR]

KCLWSU07 + [COLOUR] + [COM] - Upholstered seat pad

KCWU07 + [COLOUR] + [COM] - Upholstered inner shell

Polypropylene shell / 4-Legged frame in black, chrome & white / Optional seat pad or inner shell upholstered in [COM] / Available in anthracite, black, blue, green, orange, sand, turquoise or white

\*Fabric requirements : 0,6m seat upholstery  
(0,6m for 2 x seats) / 1,1m inner shell upholstery

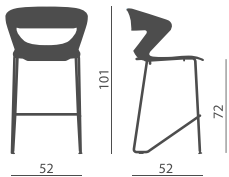

### KICCA SLOPE SLED BARSTOOL

#### KCSD07 + [COLOUR]

KCSDSU07 + [COLOUR] + [COM] - Upholstered seat pad

KCSDU07 + [COLOUR] + [COM] - Upholstered inner shell

Polypropylene shell / Black slope sled base / Optional seat pad or inner shell upholstered in [COM] / Available in anthracite, black, blue, green, orange, sand, turquoise or white

\*Fabric requirements : 0,6m seat upholstery  
(0,6m for 2 x seats) / 1,1m inner shell upholstery

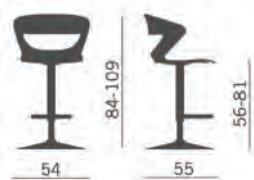

### KICCA COCKTAIL BARSTOOL

#### KCC07 + [COLOUR]

KCCSU07 + [COLOUR] + [COM] - Upholstered seat pad

KCCU07 + [COLOUR] + [COM] - Upholstered inner shell

Polypropylene shell / Gas height adjustable / Chrome swivel cocktail base with footrest / Optional seat pad or inner shell upholstered in [COM] / Available in anthracite, black, blue, green, orange, sand, turquoise or white

\*Fabric requirements : 0,6m seat upholstery  
(0,6m for 2 x seats) / 1,1m inner shell upholstery





## KALEA 4-LEGGED BARSTOOL

BLACK FRAME  
KLB07 + [COLOUR]  
KLBSU07 + [COLOUR] + [COM] - Upholstered seat pad

CHROME FRAME  
KL07 + [COLOUR]  
KLSU07 + [COLOUR] + [COM] - Upholstered seat pad

WHITE FRAME  
KLW07 + [COLOUR]  
KLWSU07 + [COLOUR] + [COM] - Upholstered seat pad

Polypropylene shell with matt inner & gloss outer / 4-Legged frame in black, chrome & white / Optional seat pad upholstered in [COM] / Available in black, turquoise or white

\*Fabric requirements : 0,6m seat upholstery (0,6m for 2 x seats)



KALEA COLOURS



BLACK [BLK]



TURQUOISE [TQ]



WHITE [WH]



## KALEA SLED SLOPE BARSTOOL

KLSD07 + [COLOUR]  
KLSDSU07 + [COLOUR] + [COM] - Upholstered seat pad

Polypropylene shell with matt inner & gloss outer / Black slope sled base / Optional seat pad upholstered in [COM] / Available in black, turquoise or white

\*Fabric requirements : 0,6m seat upholstery (0,6m for 2 x seats)



## KALEA COCKTAIL BARSTOOL

KLC07 + [COLOUR]  
KLCSU07 + [COLOUR] + [COM] - Upholstered seat pad

Polypropylene shell with matt inner & gloss outer / Gas height adjustable / Chrome swivel cocktail base with footrest / Optional seat pad upholstered in [COM] / Available in black, turquoise or white

\*Fabric requirements : 0,6m seat upholstery (0,6m for 2 x seats)

The KALEA barstool & charis meet the following international standards : CATAS Certified.

Images shown for display purposes only. Actual finishes may vary.



## **KALEA 4-LEGGED CHAIR**

### **BLACK FRAME**

**KL06 + [COLOUR]**

**KLBSU06 + [COLOUR] + [COM]** - Upholstered seat pad

### **CHROME FRAME**

**KL06 + [COLOUR]**

**KLBSU06 + [COLOUR] + [COM]** - Upholstered seat pad

### **WHITE FRAME**

**KLW06 + [COLOUR]**

**KLWSU06 + [COLOUR] + [COM]** - Upholstered seat pad

Polypropylene shell with matt inner & gloss outer /  
4-Legged frame in black, chrome or white / Optional seat pad  
upholstered in [COM] / Available in black, turquoise or white

\*Fabric requirements : 0,6m seat upholstery (0,6m for 2 x seats)



100%  
EXCLUSIVE



**BOBO**, THIS SLENDER STOOL COMPOSED OF A FIBREGLASS REINFORCED SEAT AND STEEL FRAME, GIVES CHARACTER TO ANY ENVIRONMENT WITH ITS SIMPLICITY.

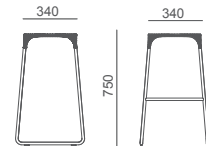

### **BOBO** BARSTOOL

**BB07AAN** - Anthracite frame

**BB07 + [COLOUR]** - Chrome frame

Fibreglass filled polypropylene seat / Anthracite frame available with anthracite seat / Chrome frame available with anthracite, sand, yellow or white seat

#### BOBO COLOURS



ANTHRACITE  
[AN]



SAND  
[SD]



YELLOW  
[YL]



WHITE  
[WH]

The **BOBO** barstool meets the following international standard : **CATAS Certified**.

Images shown for display purposes only. Actual finishes may vary.



GIN & TONIC COLOURS



BLACK  
[BLK]



DARK BLUE  
[BL]



LIME GREEN  
[LG]



ORANGE  
[OR]



RED  
[RD]



WHITE  
[WH]

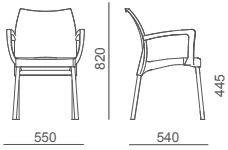

**GIN ARMCHAIR**

**GN06 + [COLOUR]**

Stackable polypropylene shell / Anodized aluminium legs / UV resistant / Available in black, dark blue, lime green, orange, red or white

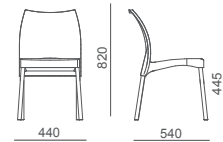

**TONIC SIDE CHAIR**

**TN06 + [COLOUR]**

Stackable polypropylene shell / Anodized aluminium legs / UV resistant / Available in black, dark blue, lime green, orange, red or white



**SMARTLINE**, MODERN SLIM PROFILE, PERFECT FOR INDOOR & OUTDOOR USE. MOULDED TOPS COMPRESSED AT HIGH PRESSURE & TEMPERATURE LEVELS RESULTING IN A PRODUCT THAT IS RESISTANT TO MOISTURE, DIMENSIONAL STABILITY & DURABLE.



24 MONTHS

Top quality  
Made in Australia

XD  
by Xero

### SMARTLINE TABLE TOPS

Round & square table tops / Available in Oak Light & White

**SMT700R + [OL/WH]** - Round top  
700 Ø x 12mm

**SMT800R + [OL/WH]** - Round top  
800 Ø x 12mm

**SMT800S + [OL/WH]** - Square top  
800 (W) x 800 (D) x 12mm

SMARTLINE TABLE TOP FINISHES



OAK LIGHT  
[OL]



WHITE  
[WH]

### SMARTLINE TABLE TOP **USEFUL TIPS:**

- Use water & mild detergent for daily cleaning
- Certain decors may not be suitable for use in direct sunlight
- We recommend only light decors for use in sunny areas
- Do not stack tables on top of each other



**CLIP**, ESPECIALLY DESIGNED TO TAKE UP VERY LITTLE SPACE. FEATURING A CENTRAL SUPPORT WITH FOUR SPOKES IN FIBREGLASS RESIN MAKING IT WITHSTAND EVEN COASTAL WEATHER.



#### **CLIP** BASE ONLY

**CLP04AN**  
540 (W) x 540 (D) x 745 (H)

Fibreglass polypropylene table base in anthracite finish /  
Adjustable ferrules

\*Suitable for: 800 Ø Round & 800 x 800 Square tops

The **CLIP** base meets the following international standard : **CATAS Certified**.  
Images shown for display purposes only. Actual finishes may vary.



100%  
EXCLUSIVE



### HAPPY HOUR BASE ONLY

**DINING 690 (H)** - Suitable for 600 - 800mm round or square table tops  
**HH01 + [BLK/CH/WH]**  
500 Ø x 690 (H)

**BAR 1100 (H)** - Suitable for 600 - 700mm round or square table tops  
**HH02 + [BLK/CH/WH]**  
500 Ø x 1100 (H)

Tulip style disc base / Available in Black [BLK], Chrome [CH] or White [WH]

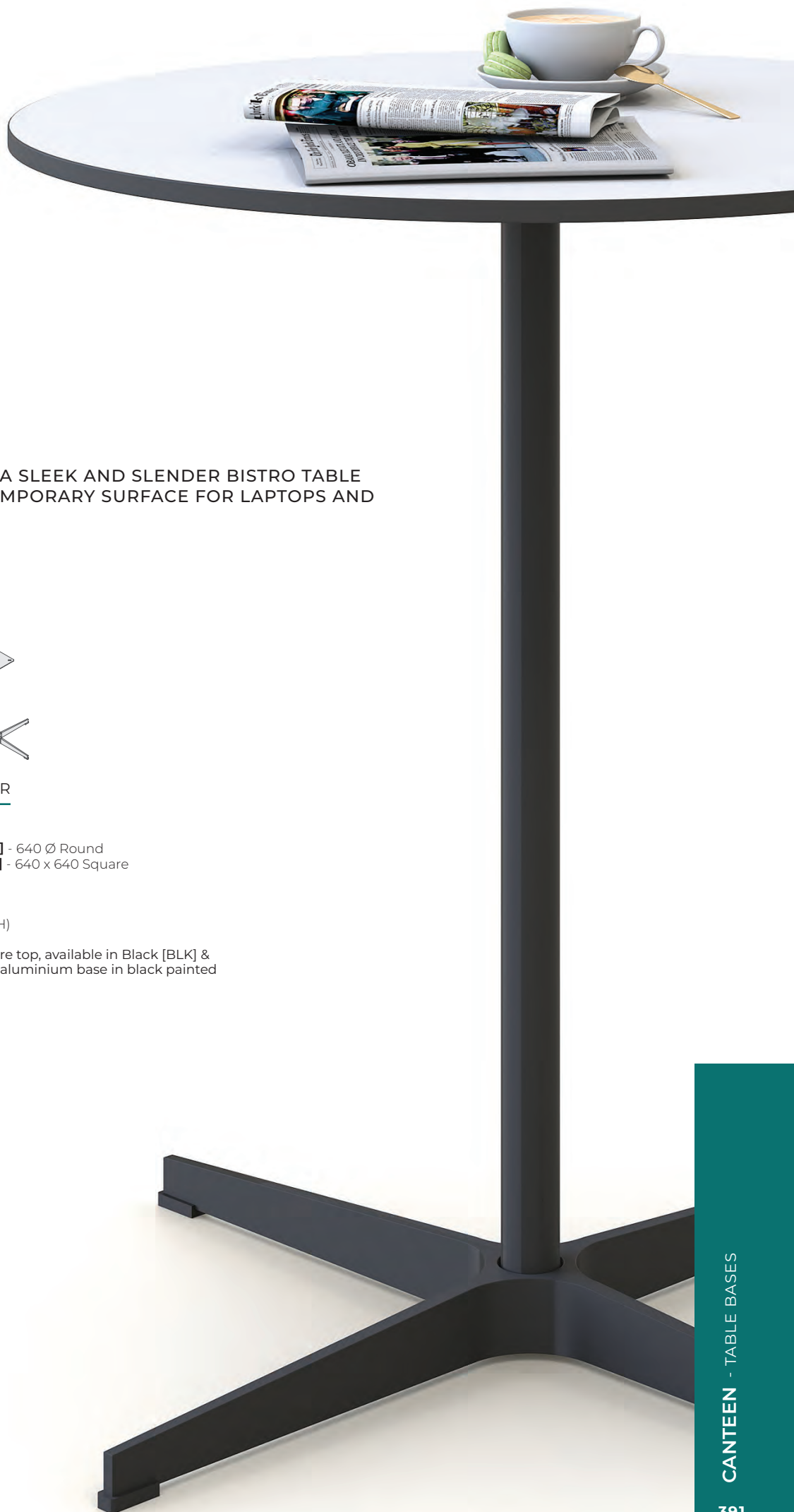

THE **BARON** A SLEEK AND SLENDER BISTRO TABLE OFFERING A TEMPORARY SURFACE FOR LAPTOPS AND COFFEE CUPS.

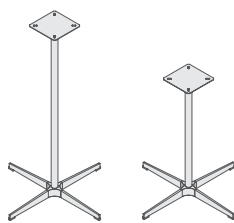

### **BARON** 4-STAR

#### TOPS

**BT640R + [BLK/WH]** - 640 Ø Round

**BT640S + [BLK/WH]** - 640 x 640 Square

#### BASES

**BA738BLK** - 738 (H)

**BA1088BLK** - 1088 (H)

12mm Thick solid core top, available in Black [BLK] & White [WH] / 4-Star aluminium base in black painted finish



LAMINATE FINISHES



ACACIA [AC]



DARK EUCALYPTUS [DE]



NATURAL WALNUT [NW]



TAORMINA ASH [TA]



TRUE OAK [TO]



ANTHRACITE [AN]



STONE GREY [SG]



WHITE [WH]

**FRESCO TABLES**

**CAFÉ 720 (H)**  
**FRS700R/S + [FINISH]** - 700 Top  
**FRS800R/S + [FINISH]** - 800 Top  
**FRSS7012 + [BLK/SI/WH]** - Base 710 (H)  
 Suitable for 700 - 800mm round or square table tops

**DOUBLE DINING 720 (H)**  
**FRS1280 + [FINISH]** - Top  
**FRSD1200 + [BLK/SI/WH]** - Base 710 (H)  
 Suitable for 1200 x 800mm table top

**BAR 1080 (H)**  
**FRS700R/S + [FINISH]** - Top  
**FRSB7080 + [BLK/SI/WH]** - Base 1080 (H)  
 Suitable for 700 mm round or square table tops

25mm Top / Base available in Black [BLK], Silver [SI] or White [WH] painted finish / Double dining base with cross bar / Available in CN Exclusive laminates, Anthracite, Stone Grey & White



24  
MONTHS



### TWISTABLE CLASSIC BASE ONLY

DINING 720 (H)  
**TWC01 + [BLK/SI]**

Suitable for 600 - 800mm round or square table tops

BAR 1050 (H)  
**TWC02 + [BLK/SI]**

Suitable for 600 - 700mm round or square table tops

4-Star patented self levelling table base in Black [BLK] or Silver [SI] / Automatically compensates for uneven floor levels

### TWISTABLE SUPREME BASE ONLY

DINING 720 (H)  
**TWS01 + [BLK/SI]**

Suitable for 600 - 800mm round or square table tops

BAR 1050 (H)  
**TWS02 + [BLK/SI]**

Suitable for 600 - 700mm round or square table tops

4-Star patented self levelling table base in Black [BLK] or Silver [SI] / Automatically compensates for uneven floor levels



12  
MONTHS



### MALIBU BASE ONLY

DINING 720 (H)  
**MB04AL**

Suitable for 600 - 800mm round or square table tops

BAR 1080 (H)  
**MBB04AL**

Suitable for 600 - 700mm round or square table tops

4-Star aluminium base / Dining & bar height

LAMINATE FINISHES



ACACIA  
[AC]



DARK EUCALYPTUS  
[DE]



NATURAL WALNUT  
[NW]



TAORMINA ASH  
[TA]



TRUE OAK  
[TO]



ANTHRACITE  
[AN]



STONE GREY  
[SG]



WHITE  
[WH]



**METRO SQUARE**

**MT900 + [FINISH]**  
900 (L) x 900 (W) x 750 (H)

25mm Laminate construction /  
Available in CN Exclusive  
laminates, Anthracite, Stone Grey & White



## METRO RECTANGULAR

### TABLE

**MT1800 + [FINISH]**

1800 (L) x 900 (W) x 750 (H)

### BENCH

**MT1540 + [FINISH]**

1500 (L) x 400 (W) x 450 (H)

25mm Laminate construction / Folding panel legs / Available in CN Exclusive laminates, Anthracite, Stone Grey & White



### LEG COLOURS



BLACK  
[BLK]



ORANGE  
[OR]



RED  
[RD]



SILVER  
[SI]



YELLOW  
[YL]



WHITE  
[WH]

### WIRE TABLE

**WR900 + [AN/WH]** - Top

**UBS700 + [COLOUR]** - Leg 700 (H)

900 (L) x 900 (W) x 725 (H)

25mm Top / Tapered steel rod legs available in black, orange, red, silver, yellow or white painted finish / Available in Anthracite & White laminates with Multiplex edging





# ACCESSORIES



12  
YEARS

**FLO** IS MORE ENVIRONMENTALLY FRIENDLY, BETTER LOOKING, AND A BETTER PERFORMING PRODUCT THAN ANY OF ITS COMPETITORS. WITH GREAT DESIGN AND PERFORMANCE, **FLO** OFFERS A RANGE AND EASE OF MOVEMENT THAT SETS IT APART FROM ALL OTHER MONITOR ARMS.

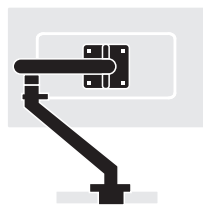

#### **FLO** SINGLE DYNAMIC ARM

FLM125 + [BLK/SI] - Desk clamp 12 - 25mm  
FLM170 + [BLK/SI] - Desk clamp 12 - 70mm

1 x Single arm including choice of desk clamp / Available in Black [BLK] or Silver [SI]

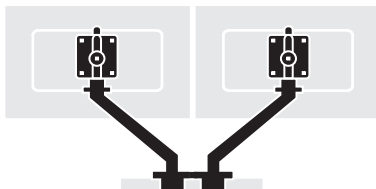

#### **FLO** DOUBLE DYNAMIC ARM

FLMD170SI\*

2 x Single arms / Double arm desk clamp accommodates 12 - 70mm thick top / Available in silver

\*Should you require a double arm in black, you can mount 2 x single arms [FLM125BLK/FLM170BLK] next to each other.

#### **FLO** FEATURES:

- Monitor load range : 3-9kg
- Horizontal reach : 581mm
- Vertical adjustment : 341mm
- Tilt range : 48,5° upwards / 48,5° downwards
- Monitor head : VESA 75 and 100 compliant
- Monitor can be positioned in either landscape or portrait format
- 180° Stop function / 360° capability
- Made of 55,7% recycled material / 100% recyclable
- Available in Black or Silver

**LIMA**, IS EASY TO INSTALL AND ADJUST AS EITHER A SINGLE OR DUAL SCREEN SOLUTION.



### **LIMA** SINGLE ARM - INCL. POST & CLAMP

**LMA001BLK**

1 x Single arm including post & clamp / Desk clamp accommodates 12 - 40mm thick top / Available in black

### **LIMA** ADDITIONAL ARM

**LMA002BLK**

Additional single arm / Available in black

\*Should you require a dual screen mount, you purchase [LMA001BLK] + [LMA002BLK]

#### LIMA FEATURES:

- Monitor load range: 0-6,5kg
- Horizontal adjustment: 456mm
- Vertical range : 210mm
- Tilt range : 80° upwards / 10° downwards
- Monitor head : VESA 75 and 100 compliant
- Monitor can be positioned in either landscape or portrait format
- 180° Stop function / 360° capability
- Made of 55,7% recycled material / 100% recyclable





12  
YEARS

UNIQUE AND EXPERTLY DESIGNED, **OLLIN** HELPS YOU INTERACT WITH TECHNOLOGY AS SEAMLESSLY AS POSSIBLE. OFFERING UNPARALLELED REACH PERFECT FOR THE EXECUTIVE DESK.

**OLLIN FEATURES:**

- Monitor load range: 0-9kg
- Horizontal reach: 674mm
- Vertical adjustment: 367mm
- Dual mount bar expands functionality to a dual screen
- Tilt range: 80° upwards / 10° downwards
- Monitor head: VESA 75 and 100 compliant
- Monitor can be positioned in either landscape or portrait format
- 180° Stop function / 360° capability
- Made of 65% recycled material / 99,5% recyclable





### **OLLIN** SINGLE DYNAMIC ARM

- OLM125BLK** - Desk clamp 12 - 25mm
- OLM170BLK** - Desk clamp 12 - 70mm

1 x Single arm including choice of desk clamp / Available in black



### **OLLIN** SINGLE DYNAMIC ARM- WITH DUAL MOUNT BAR

- OLMD125BLK** - Desk clamp 12 - 25mm
- OLMD170BLK** - Desk clamp 12 - 70mm

1 x Single arm including dual mount bar & choice of desk clamp / Available in black

Images shown for display purposes only. Actual finishes may vary.

## POWER KITS



### SUPPLY CABLE

**SC30N** - 3m  
**SC50N** - 5m  
**SC60N** - 6m

Normal power supply cable / Supplied with moulded 3 pin plug & female connector



### INTERCONNECTING CABLE

**IC15N** - 1,5m  
**IC20N** - 2m  
**IC30N** - 3m

Normal interconnecting power cable / Allow users to extend or reconfigure their office power units as required

#### DESKTOP POWER KIT

Quick and easy access to power for hot-desk users and hybrid workers.



Supply Cable - 3m



Interconnecting Cable - 1,5m



DOT EVO

#### SINGLE PKD01D + [BLK/WH]

Includes 1 x 3m supply cable / 1 x DOT EVO desktop power set

#### 2-WAY PKD02D + [BLK/WH]

Includes 1 x 3m supply cable / 1 x 1,5m Interconnecting cables / 2 x DOT EVO desktop power sets

#### 4-WAY PKD04D + [BLK/WH]

Includes 1 x 3m supply cable / 3 x 1,5m Interconnecting cables / 4 x DOT EVO desktop power sets

#### 6-WAY PKD06D + [BLK/WH]

Includes 1 x 3m supply cable / 5 x 1,5m Interconnecting cables / 6 x DOT EVO desktop power sets

#### BELOW DESKTOP POWER KIT

Ideal for single-user desks with multiple devices (e.g. CPU's & monitors) that are permanently connected to power.



Supply Cable - 3m



Interconnecting Cable - 1,5m



GRID E

#### SINGLE PK01UD

Includes 1 x 3m supply cable / 1 x GRID E below desktop power set

#### 2-WAY PK02UD

Includes 1 x 3m supply cable / 1 x 1,5m Interconnecting cable / 2 x GRID E below desktop power sets

#### 4-WAY PK04UD

Includes 1 x 3m supply cable / 3 x 1,5m Interconnecting cables / 4 x GRID E below desktop power sets

#### 6-WAY PK06UD

Includes 1 x 3m supply cable / 5 x 1,5m Interconnecting cables / 6 x GRID E below desktop power sets



Black  
[DE11NBLK]



White  
[DE11NWH]

## DOT EVO

DE11N + [BLK/WH]

1 x South African 16 Amp 3 Pin / 1 x South African compact 16 Amp 3 Pin / 1 x USB A Quick Charger technology (QC) max 10W / 1 x USB C Power Delivery technology (PD) max 30W / Available in Black [BLK] or White [WH]

\*Fits standard 80mm grommet hole



## GRID E - NORMAL

GE22N

2 x Modules each consisting of: 1 x Standard South African 16 Amp 3 Pin with compact South African 16 Amp 3 Pin / Blue LED "power on" indicator / Powder coated body with black end caps for strong & robust durability

## FULL POWER KIT

The combination of **Desktop Power** and **Below Desktop Power** is the most convenient solution and covers all permanent power and charging needs.



Supply Cable - 3m



Interconnecting Cable - 1,5m



GRID E



DOT EVO

### SINGLE PKD01FK + [BLK/WH]

Includes 1 x 3m supply cable / 1 x DOT EVO desktop power set / 1 x GRID E below desktop power set

### 2-WAY PKD02FK + [BLK/WH]

Includes 1 x 3m supply cable / 1 x 1,5m Interconnecting cables / 2 x DOT EVO desktop power sets / 2 x GRID E below desktop power sets

### 4-WAY PKD04FK + [BLK/WH]

Includes 1 x 3m supply cable / 3 x 1,5m Interconnecting cables / 4 x DOT EVO desktop power sets / 4 x GRID E below desktop power sets

### 6-WAY PKD06FK + [BLK/WH]

Includes 1 x 3m supply cable / 5 x 1,5m Interconnecting cables / 6 x DOT EVO desktop power sets / 6 x GRID E below desktop power sets

## GRID E - CLEAN

GE22C

2 x Standard South African 16 Amp 3 Pin with 2 x compact South African 16 Amp 3 Pin / Blue LED "power on" indicator / Powder coated body with black end caps for strong & robust durability



## SUPPLY CABLE



SC30C - 3m  
SC50C - 5m  
SC60C - 6m

Clean power supply cable / Supplied with moulded 3 pin plug & female connector

## INTERCONNECTING CABLE

IC15C - 1,5m  
IC20C - 2m  
IC30C - 3m

Clean interconnecting power cable / Allow users to extend or reconfigure their office power units as required

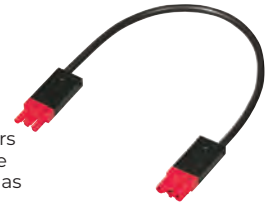

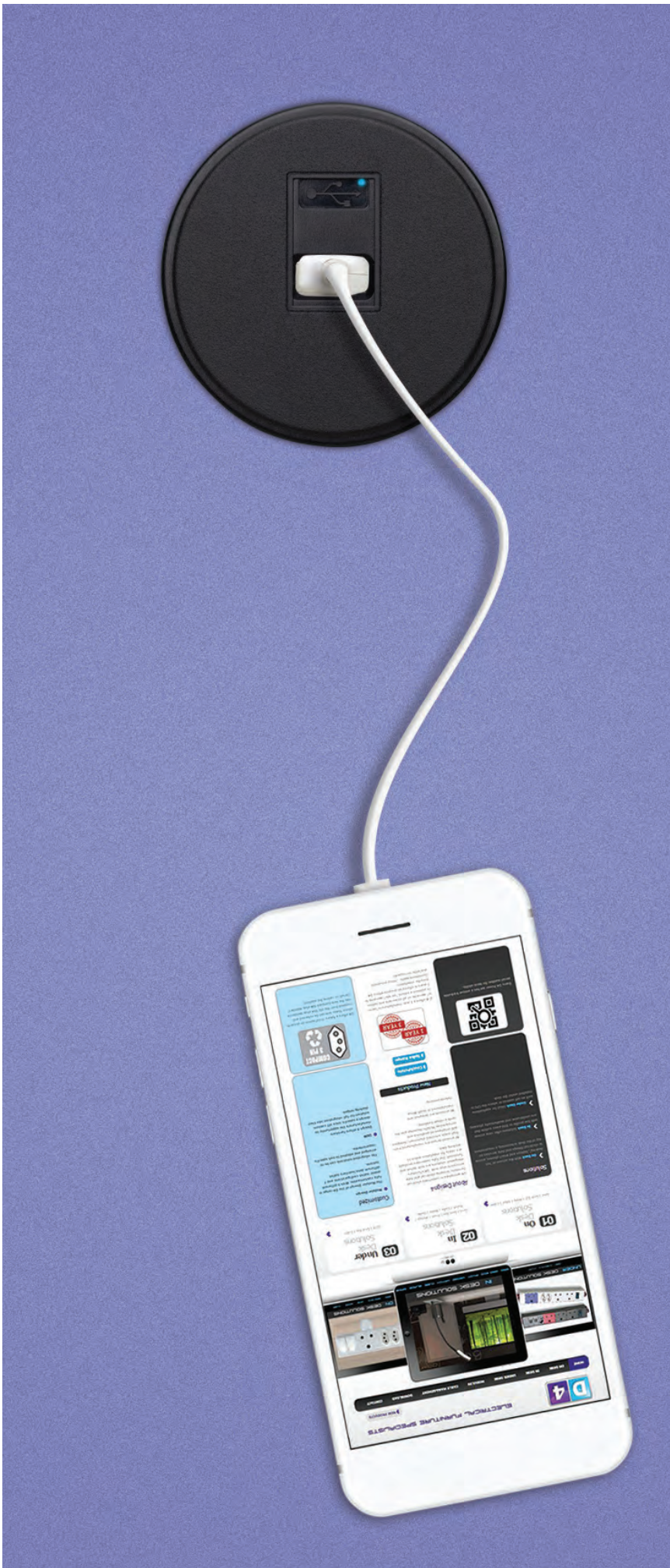

## MICRODOT

MD2USBBLK

1 x Bi-directional USB Type-A 18 Watt QC (Quick Charge) charger / Available in Black

\*Cut-out: 60mm Ø



Black  
[DE11NBLK]



White  
[DE11NWH]

## DOT EVO

DE11N + [BLK/WH]

1 x South African 16 Amp 3 Pin / 1 x South African compact 16 Amp 3 Pin / 1 x USB A Quick Charger technology (QC) max 10W / 1 x USB C Power Delivery technology (PD) max 30W / Available in Black [BLK] or White [WH]

\*Fits standard 80mm grommet hole



## PIVOT IN DESK - USB TYPE-A

### HORIZONTAL POWER SET PT22N + [FINISH]

1 x Illuminated over load switch / 2 x Standard 3 pin South African 16 Amp socket / 1 x Compact 3 pin South African 16 Amp socket / 1 x Bi-directional USB Type-A 18 Watt QC (Quick Charge) charger / 1 x HDMI with 35cm fly lead / 1 x Data pass thru / Available in Graphite [BLK] & Titanium [SI] finish

\*Cut-out: 297 (L) x 135 (W) mm

## PIVOT IN DESK - USB TYPE-C

### HORIZONTAL POWER SET PTV22N + [FINISH]

1 x Illuminated over load switch / 2 x Standard 3 pin South African 16 Amp socket / 1 x Compact 3 pin South African 16 Amp socket / 1 x USB Type-C 20 Watt PD (Power Delivery) charger / 1 x HDMI with 35cm fly lead / 1 x Data pass thru / Available in Graphite [BLK] & Titanium [SI] finish

\*Cut-out: 297 (L) x 135 (W) mm



## BLADE 2 EVO POWER SET

### BLADE 2 - IN DESK POWER SET BL2EV22N + [BLK/SI]\*

2 x South African 16 Amp 3 pin / 2 x South African compact 3 pin / 1 x Bi-directional USB Type-A 18 Watt QC (Quick Charge) charger / 1 x USB Type-C 20 Watt PD (Power Delivery) charger / 1 x HDMI with 35cm fly lead / 1 x Data pass thru / Blue LED power on indicator / Available in Graphite [BLK] or Titanium [SI]

\*Cut-out: 270 (L) x 57 (W) mm



## BLADE 2 ECO POWER SET

### BLADE 2 - IN DESK POWER SET BL2EC22N + [BLK/SI]\*

2 x South African 16 Amp 3 pin / 2 x South African compact 3 pin / 1 x Bi-directional USB Type-A 18 Watt QC (Quick Charge) charger / 1 x USB Type-C 20 Watt PD (Power Delivery) charger / 1 x HDMI with 35cm fly lead / 1 x Data pass thru / Blue LED power on indicator / Available in Graphite [BLK] or Titanium [SI]

\*Cut-out: 270 (L) x 57 (W) mm



## BLADE 1 ECO POWER SET

### BLADE 1 - IN DESK POWER SET BL1EC21N + [FINISH]\*

1 x South African 16 Amp 3 pin / 1 x South African compact 3 pin / 1 x Bi-directional USB Type-A 18 Watt QC (Quick Charge) charger / 1 x USB Type-C 20 Watt PD (Power Delivery) charger / Blue LED power on indicator / Available in Graphite [BLK] or Titanium [SI]

\*Cut-out: 145 (L) x 57 (W) mm

### POWER SET FINISHES



\*Approved by National Regulator for Compulsory Standard [NRCS]  
141054/001 & 136638/001



\*Supplier is an associate member of  
Safe House Association

## POWER FOR SIT/STAND DESKS



### SUPPLY CABLE

SC30N - 3m

Normal power supply cable / Supplied with moulded 3 pin plug & female connector

### CURLY SUPPLY CABLE

CSC30N - 3m

Normal curly power supply cable / Supplied with moulded 3 pin plug & female connector



### DOUBLE CURLY

#### INTERCONNECTING CABLE

DCIC35N

Double curly cord - male connector connecting 2 x 3,5m spiral cables with female connector on ends

\*Brings power from Evo Duo sit/stand lower cable tray to the upper cable tray.

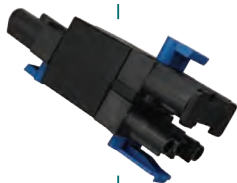

### SPLITTER BLOCK

SB3

Splitter block - 2 x female connectors / 1 x male connector

\*Connects supply cable to the double curly cord.



### INTERCONNECTING CABLE

IC15N - 1,5m

Normal interconnecting power cable / Used to connect 2 x Evo Duo sit/stand workstations



CLASSIC, COMPACT AND FLEXIBLE - THE **HULA** DESK LAMP PROVIDES PERSONAL, PRECISELY POSITIONED LIGHT TO CREATE A HOLISTIC WORK SETTING.

### **HULA LED USB** DESK LAMP

#### **HULA9 + [BLK/WH]**

LED USB desk lamp with metal and acrylic body / Flexible head / Available in Black [BLK] or White [WH]

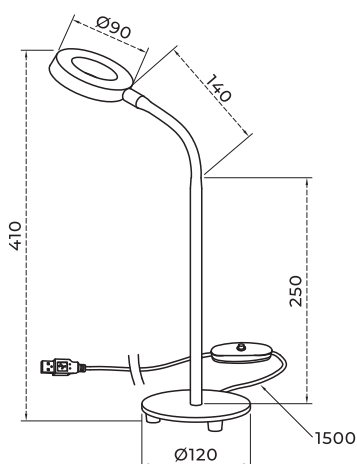

#### **HULA FEATURES:**

- Exceptional colour accuracy (CRI > 90%)
- Colour temperature of 4000 Kelvin make for an incredibly soft bright light
- Low power consumption with no UV emissions
- USB Power source min. requirement: 5V 2A
- LED Power: 10 Watt



\*Approved by National Regulator for Compulsory Standard [NRCS]  
141054/001 & 136638/001



\*Supplier is an associate member of  
Safe House Association

Images shown for display purposes only. Actual finishes may vary.



**KELA**, IS CHARACTERIZED BY ITS SOFT AND TIMELESS SHAPES. THE MODULES ARE EQUIPPED WITH A DOUBLE CLICK SYSTEM : FIRST CLICK, THE STRUCTURE REMAINS FLEXIBLE, DOUBLE CLICK, IT GETS RIGID.

## KELA SUPPLY CABLE

- KELA2500CL** - Ceiling kit with 50 x Kela Big connectors in Transparent
- KELA2500SCL** - Ceiling kit with 50 x Kela Small connectors in Transparent
- KELA2500SBLK** - Ceiling kit with 50 x Kela Small connectors in Black

KELA kit is used to bring power and data cables from the ceiling to the cable outlet in the desk top. It's a vertical cable management system made up of 50 x Black or Transparent polycarbonate connectors, including ceiling kit.

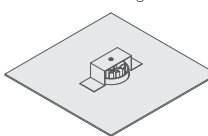
### COMPONENTS OF **KELA**:

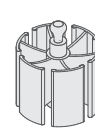
<p>KELA Ceiling Kit</p>  <p><b>KELAKIT</b> Includes top hat bracket, white ceiling trim, MDF board &amp; 1 x Big Kela connector</p>	<p>KELA Big Connector</p>  <p><b>K8080TT</b> 58 Ø x 40 (H) 12 x Cable channels</p>	<p>KELA Small Connector</p>  <p><b>K8045 + [BLK/TT]</b> 45,4 Ø x 40 (H) 6 x Cable channels</p>
--	---	---



## CABLE WORM

**VERTICAL CABLE TIDY**  
**CWM01 + [BLK/SI]**

The flexible coil design easily allows for convenient cable management for all styles of sit-stand desks as well as fixed-height work surfaces / Available in Black [BLK] or Silver [SI]





### **METAL CPU TOWER CLAMP**

**BFWCPU + [BLK/SI/WH]**

Swivel & adjustable / Available in Black [BLK], Silver [SI] & White [WH] painted finish

### **SNAIK CABLE TIDY**

**BLS001** - Black  
**AS001** - Grey

Moulded cable carrier consisting of 3 cavities / Horizontal application / 1 Meter length / Available in black & grey



### **LINK-IT CABLE TIDY**

**VERTICAL CABLE TIDY**  
**LKH01 + [BLK/SI/WH]**

Universal cable carrier consisting of 2 cavities / Vertical application with weighted base / Fixes to underside of desk with flexi clip / Available in Black [BLK], Silver [SI] & White [WH]

### **RAMP-IT FLOOR TRUNKING**

**RC1000BLK**

Individual cable cover / 1m Length / Black rubber







## POLYBIN WASTE BIN

**WB240P + [BLK/SI]**  
230 Ø x 230 (H)

Polypropylene waste bin / Available in Black [BLK] or Silver [SI]

## PERFORATED ACCESSORIES

Metal construction with punch detail / Available in Black [BLK], Silver [SI] & White [WH] painted finish

**P402 + [BLK/SI/WH]** - 2 Tier letter tray  
**P504 + [BLK/SI/WH]** - Waste bin



## SIMPLICITY ACCESSORIES

Metal construction / Available in black, silver or white painted finish

**SM402 + [BLK/SI/WH]** - 2 Tier letter tray  
**SM401 + [BLK/SI/WH]** - Single letter tray  
**SM504 + [BLK/SI/WH]** - Waste paper bin  
**SM408 + [BLK/SI/WH]** - paper cube  
**SM404 + [BLK/SI/WH]** - pencil cup

## INNOVATION BINS

**SAB784 + [BLK/SI/SS/WH]** - Litter bin  
240 Ø x 600 (H)

**SAB765 + [BLK/SI/SS/WH]** - Wide Litter bin  
400 Ø x 600 (H)

Metal litter bins available in Black [BLK], Silver [SI], Stainless Steel [SS] & White [WH] with stainless steel funnel lid



## SOLID ASHTRAY LITTER BINS

**SAB506 + [BLK/SI/SS/WH]** - Litter bin  
240 Ø x 600 (H)

Metal ashtray litter bin available in Black [BLK], Silver [SI], Stainless Steel [SS] & White [WH]



### **SIGNATURE** HAT & COAT STAND

**CS817 + [BLK/SI]**  
380 (W) x 380 (D) x 1750 (H)

Disc base & column in Black [BLK] or Silver [SI] painted finish / 6 Chrome hooks



### **Y-DOUBLE** HAT & COAT STAND

**COA002 + [BLK/WH]**  
200 (W) x 200 (D) x 1800 (H)

2 x Coat hooks / Available in Black paired with Silver [BLK] / White paired with Silver [WH]



### **CORNETTO** HAT & COAT STAND

**CR1670BLK** - Metal disc base  
460 (W) x 530 (D) x 1670 (H)

**CR1680WH** - Metal 3-legged stand  
460 (W) x 530 (D) x 1680 (H)

Metal stand including umbrella holder & polypropylene coat hangers / Available in Black [BLK] or White [WH] painted finish

## ERGO FOOTREST

**AFR010CBL**

Ergonomic black rubber coated board on chrome frame



## CURVE FLOOR PROTECTOR

Misty clear in colour / Rounded corners / Mild leather grain to upper surface / Nonslip undersurface: Ideal for low piled carpets, tiled and wooden floors / Spiked undersurface: Ideal for deep piled carpets

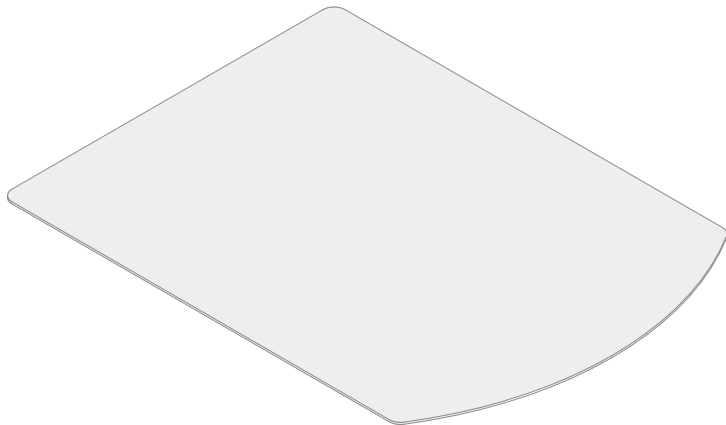

### **NON-SLIP UNDERSURFACE**

**CURVED FRONT**  
**CPC1200CL**  
1200 (L) x 900 (W)

**CURVED FRONT**  
**CPC1350CL**  
1350 (L) x 1140 (W)

**RECTANGULAR**  
**CPR1800CL**  
1800 (L) x 1200 (W)

### **SPIKED UNDERSURFACE**

**CURVED FRONT**  
**CPC1200SCL**  
1200 (L) x 900 (W)

## PU CASTORS

**PUCASTOR**

50mm for use on tiles & wooden floors / Set of 5



## NYLON CASTORS

**CODE55**

60mm for use on carpet / Set of 5

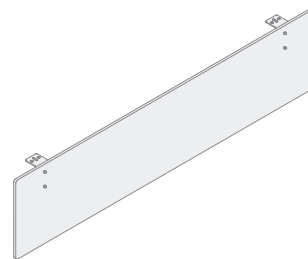

### PERSPEX MODESTY PANELS

5mm Perspex construction / Includes brackets / Available in Matt Black [BLK] or Polar White [WH]

**PX1500 + [BLK/WH]**

1500 (L) x 300 (H)

**PX1300 + [BLK/WH]**

1300 (L) x 300 (H)

### GLOBAL MUTE MODESTY PANEL

9mm 100% Polyester construction / Includes brackets / Available in anthracite, black, cloud blue, leaf green, marble, lime, sage green, serenity blue or slate grey

**GPM1500 + [COLOUR]**

1500 (L) x 300 (H)

**GPM1300 + [COLOUR]**

1300 (L) x 300 (H)

#### 100% POLYESTER COLOURS



ANTHRACITE [AN]



BLACK [BLK]

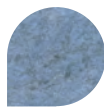

CLOUD BLUE [BL]



LEAF GREEN [GRN]

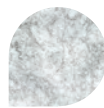

MARBLE [MR]



LIME [LM]



SAGE GREEN [SG]



SERENITY BLUE [SBL]

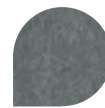

SLATE GREY [GR]

100% Polyester is extremely durable and requires little attention to maintain. Light dusting on a regular basis will prevent dust build up. Most marks can be cleaned with a mild detergent solution, followed by rinsing and blotting.

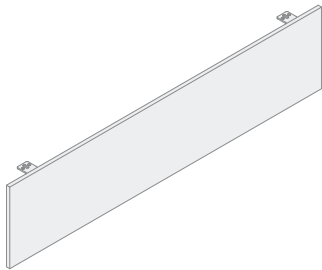

### GLOBAL MODESTY PANELS

Modesty panel includes brackets / Available in CN Exclusive laminates, Anthracite, Black, Stone Grey & White

**GMP1700 + [FINISH]**  
1700 (L) x 340 (H) x 16mm

**GMP1500 + [FINISH]**  
1500 (L) x 340 (H) x 16mm

**GMP1300 + [FINISH]**  
1300 (L) x 340 (H) x 16mm

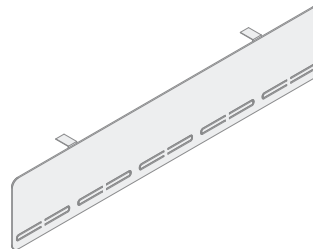

### WORX 4 U MODESTY PANELS

Metal construction with punch detail / Includes brackets / Available in Black [BLK], Silver [SI] or White [WH]

**WX1700 + [BLK/SI/WH]**  
1700 (L) x 300 (H)

**WX1500 + [BLK/SI/WH]**  
1500 (L) x 300 (H)

**WX1300 + [BLK/SI/WH]**  
1300 (L) x 300 (H)

#### LAMINATE FINISHES



THE SLIM, ELEGANT **THINK-BOARD** WITH ITS WHITE BOARD WRITING SURFACE TO TOP & SOUND ABSORBENCY PANELS TO BOTTOM, THIS BOARD CAN ALSO HELP HUSH OPEN-PLAN SPACES WHILE CREATING A LITTLE SLICE OF CALM.



### MUTE PIN-BOARD

**MPB8060 + [COLOUR]** - 800 (W) x 600 (H) x 9mm  
**MPB1280 + [COLOUR]** - 1200 (W) x 800 (H) x 9mm

Pinable surface / 100% Recyclable polyester panel / Attaches to wall with a clear / Available in Anthracite, Black, Cloud Blue, Leaf Green, Marble, Lime, Sage Green, Srenity Blue or Slate Grey

### THINK-BOARD

**THB9018 + [COLOUR]**  
 900 (W) x 500 (D) x 1800 (H)

Double sided non-magnetic white board writing surface / Pen ledge in True Oak laminate / 9mm 100% Polyester panel to lower sections / Black steel frame on castors / Available in Anthracite, Black, Cloud Blue, Leaf Green, Marble, Lime, Sage Green, Srenity Blue or Slate Grey

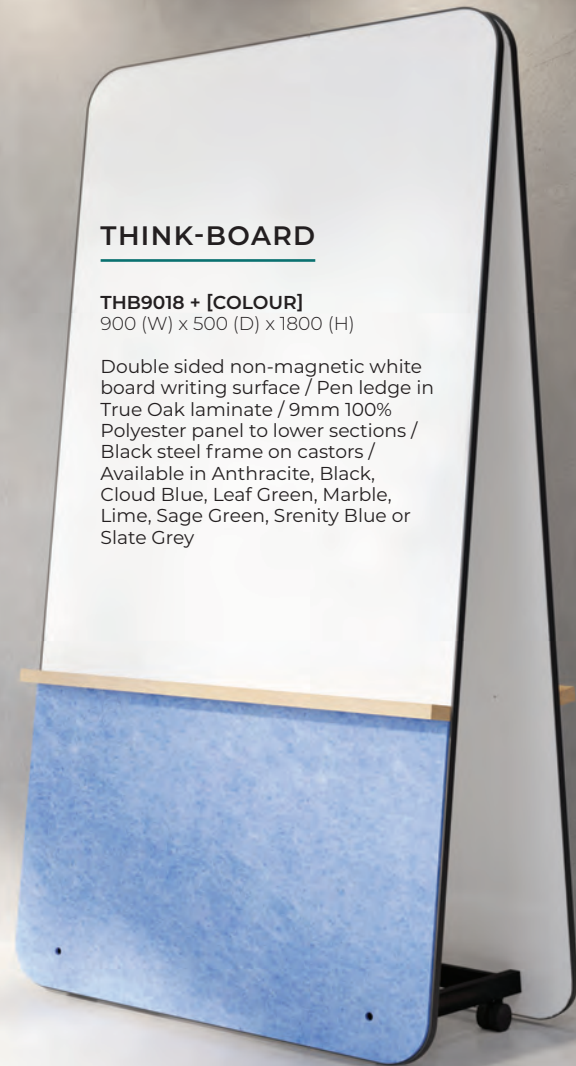

### THINK-BOARD TECH

**THBT9018 + [COLOUR]** - Think Board Tech  
 900 (W) x 500 (D) x 1800 (H)

**43FHDLED** - 43" FHD LED Screen

Anthracite laminate front surface with with non-magnetic white board writing surface to back side / Ledge in True Oak laminate / 9mm 100% Recyclable polyester panel to lower sections / Black steel frame on castors / Includes power kit (GRID power set with 5m supply cable: 2 x standard South African 3 pin, 1 x compact South African 3 pin, 1 x Bi-directional USB Type-A charger, 1 x USB Type-C charger), screen mounting bracket, 2 meter USB 3.0 extension cable, 5 meter HDMI high speed cable / Available in Anthracite, Black, Cloud Blue, Leaf Green, Marble, Lime, Sage Green, Srenity Blue or Slate Grey

#### 100% POLYESTER COLOURS



ANTHRACITE [AN]

BLACK [BLK]

CLOUD BLUE [BL]

LEAF GREEN [GRN]

MARBLE [MR]

LIME [LM]

SAGE GREEN [SG]

SERENITY BLUE [SBL]

SLATE GREY [GR]

100% Polyester is extremely durable and requires little attention to maintain. Light dusting on a regular basis will prevent dust build up. Most marks can be cleaned with a mild detergent solution, followed by rinsing and blotting.



A MINIMALIST TAKE ON THE TRADITIONAL WHITBOARD. OUR **GLASS WHITEBOARDS** HAVE BEEN DESIGNED WITH AESTHETICS, FUNCTIONALITY AND USER EXPERIENCE AT THE FOREFRONT.

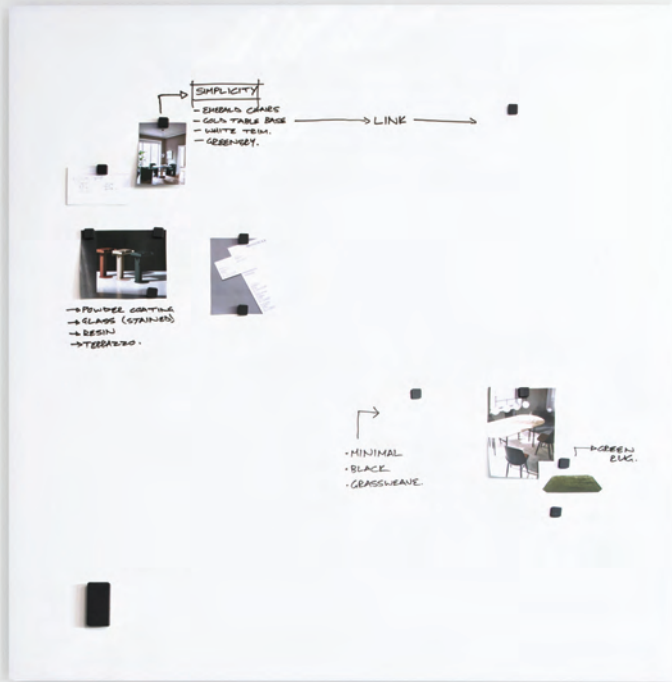

### FRAMELESS MAGNETIC

**GWBFL1290**  
1200 (W) x 900 (H)

**GWBFL1512**  
1500 (W) x 1200 (H)

**GWBFL1690**  
1600 (W) x 900 (H)

**GWBFL1812**  
1800 (W) x 1200 (H)

**GWBFL2090**  
2000 (W) x 900 (H)

**GWBFL2412**  
2400 (W) x 1200 (H)

Magnetic surface / Long lasting high quality, toughened safety glass / Easy to clean & stain resistant / Easy to install / Magnetic (Rare Earth magnets only)



**RES01BLK**

Rare Earth skittle magnets each



### ON LUGS NON-MAGNETIC

**GWBSLL1290**  
1200 (W) x 900 (H)

**GWBSLL1690**  
1600 (W) x 900 (H)

**GWBSLL2090**  
2000 (W) x 900 (H)

Non-magnetic surface / Long lasting high quality, toughened safety glass / Easy to clean & stain resistant / Easy to install / Fits to wall with stainless steel lugs



**ACCESSORIES**

**GWBACC**

Holder, duster & 2 x markers



## WHITEBOARD MAGNETIC

**BD0968** - 1800 (W) x 1200 (H)  
**BD0970** - 2000 (W) x 1200 (H)  
**BD0976** - 2400 (W) x 1200 (H)

Magnetically receptive Steel surface / Concealed mounting (wall screws and masonry plugs supplied, 6mm) / Additional mounting brackets for boards larger than 1500mm / Slide-in aluminium pen tray (450 x 35mm)\* / Can be used with the Easy Rail System / Anodised aluminium frame / Can be mounted horizontally or vertically / Includes mounting instructions.

\*Boards larger than 1500\*1200mm are supplied with two 450\*35mm pen trays

## YEAR PLANNER MAGNETIC

**YP1200** - 1200 (W) x 900 (H)  
**YP1500** - 1500 (W) x 1200 (H)

Magnetically receptive Steel surface / Concealed mounting (wall screws and masonry plugs supplied, 6mm) / Additional brackets for boards larger than 1500mm / Slide-in aluminium pen tray (450 x 35mm)\* / Can be used with the Easy Rail System / Anodised aluminium frame.

Year Planner is supplied with: Markers / Magnetic Date Strips / Public Holiday indicators / Planning Shapes / 2 Label Carriers

\*Boards larger than 1500 x 1200mm supplied with two pen trays

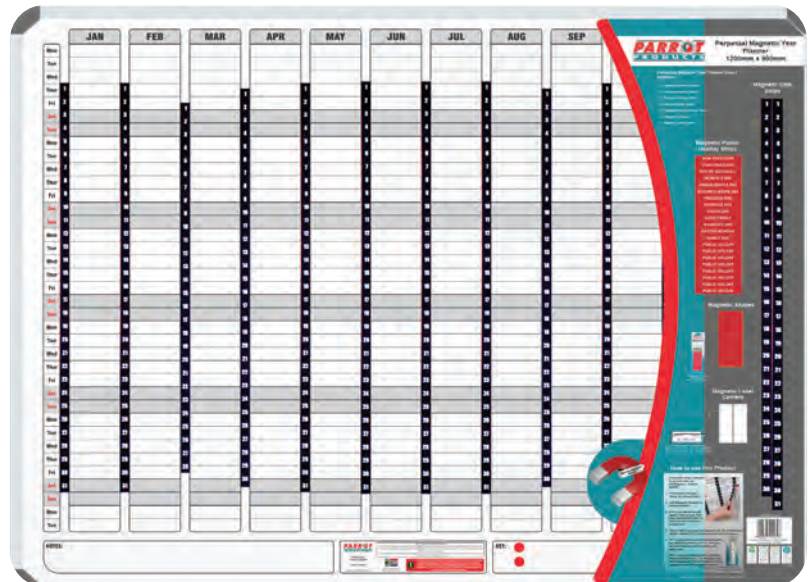

## INFO BOARD FELT

**BB9060B** - 900 (W) x 600 (H)  
**BB1590B** - 1500 (W) x 900 (H)

Concealed mounting (wall screws and masonry plugs supplied, 6mm) / Additional brackets for boards larger than 1500mm / Can be used with the Easy Rail System / Anodised aluminium frame / Can be mounted horizontally or vertically / Black felt surface

## FLIPCHART DELUXE

BD9145

Magnetically receptive steel whiteboard surface / Dry erase surface / Removable Ruler / Spring loaded paper gripper / Integrated folding pen tray / Height adjustable up to 1960mm / Lockable castors / Extendable side arms to display additional pages

\*Whiteboard Size: 680 (W) x 1000 (H)



## FLIPCHART STANDARD

BD9131A

Non-Magnetic surface / Height adjustable telescopic legs / Paper clamp / Self-adjusting hinge for centre leg / Integrated pen tray / Maximum overall height 1840mm / Locking clip at back / End Caps / In Locked position, middle leg can be used as a carry handle

Flipchart Standard is supplied with: Whiteboard Markers Bulletin Tip 10 Assorted colours / Flipchart Paper Newsprint 20 Sheets





## ORTHOMAT® PREMIUM

**FF906BLK**

900 (L) x 600 (W)

### REDUCES STANDING FATIGUE FOR THOSE THAT MOVE AT WORK

- Exceptional fatigue-relief properties – a real investment for the workplace
- Dual layer construction for superior comfort and durability
- Tough textured top surface for excellent resilience against wear and tear
- Insulates against the effects of cold concrete floors
- Low density under layer provides extremely effective underfloor cushioning
- Ideal for demanding locations, especially where regular turning is involved
- Product Height: 12.5 mm
- Tapered edges to reduce trip hazards
- Fire tested to BS EN 13501-1



## ORTHOMAT® OFFICE

**OM805BLK**

800 (L) x 500 (W)

### THE ANTI-FATIGUE MAT FOR OFFICE WORKERS

- Improves overall posture and wellbeing when standing in static positions
- Provides just the right balance between cushioning and foot support for users of sit/standing desks
- Helps to delay the onset of pain and tiredness otherwise experienced from standing on hard or firm floor surfaces
- Textured underside keeps this anti-fatigue mat in place
- Gentle bevelled edges to reduce trip hazards, while creating a neat anti-curl finish that sits flush to the floor
- Highly durable, can withstand a wide range of footwear
- Handy size for ease of handling making lifting and moving an effortless task
- Fits into most office workstations
- Product height: 16 mm

**ANTI-FATIGUE MATS** STIMULATE THE CALF MUSCLES TO MOVE MORE AND IMPROVE OVERALL STANDING HEALTH. STANDING FOR LONG PERIODS OF TIME AT WORK WITHOUT APPROPRIATE FLOORING LIKE ANTI FATIGUE MATS, CAN LEAD TO HEALTH PROBLEMS SUCH AS BACK PAIN AND POOR CIRCULATION.



## **RAMPMAT**

**RP1590BLK**  
1500 (L) x 900 (W)

### **A POPULAR HONEYCOMB MAT FOR ALL ENVIRONMENTS**

- A popular choice of doormat, suitable for most climates
- The raised honeycomb design provides grip while scraping away dirt and moisture
- Moulded bevelled edging for trip-resistance and wheeled access
- Manufactured from durable rubber
- Slip tested to DIN 51130
- Product height: 14 mm



## **MICROFIBRE DOORMAT**

**MF1590BLK**  
1500 (L) x 900 (W)

**MF1812BLK**  
1800 (L) x 1200 (W)

### **WASHABLE DOORMAT WITH SUPER ABSORBENCY AND MICROFIBRE TECHNOLOGY**

- Multi-action entrance mat with hygienic microfiber technology
- Flexible, ultra-fine fibres provide deep-cleaning action on passing footwear
- Friction from the fibres generate a static charge that attracts and traps dust and debris
- Effectively penetrates those hard to reach treads on footwear and wheeled trolleys
- Superior 'brushing and wiping' with 'rapid dry' properties that outperform cotton
- Luxuriously soft pile that keeps entrances looking smart, stylish and free from lint
- Environmentally-friendly – does not require chemical pre-treatment or washing detergents
- Product height: 8 mm



## **RETRO 5 PLANTER**

20mm Square tube metal frame with  
4 x polyethylene Cubi planter boxes /  
Colour to be specified on order / Can match  
any Pantone or RAL colour in gloss or matt  
finish

### **RET005**

580 (W) x 580 (D) x 1720 (H)

### **PLANT SPECIFICATIONS**

Silk plant planted in 230 (W) x 230 (D) x  
230 (H) Polystyrene base that is painted  
brown to the top and supplied with  
bark chips



## CUPBOARD TOP TROUGH

Polyethylene planter trough / Including long deck & pipe / Colour to be specified on order / Can match any Pantone or RAL colour in gloss or matt finish

### CTT645

645 (W) x 305 (D) x 200 (H)

### PLANT SPECIFICATIONS

Silk plants planted in 530 (W) x 190 (D) x 180 (H) polystyrene base that is painted brown to the top and supplied with bark chips

\*The Cupboard Top Trough comes with a deck & pipe suitable for filling it with soil and planting live plants directly into it

## RETRO 6/7 PLANTER

20mm Square tube metal frame with polyethylene planter trough / Colour to be specified on order / Can match any Pantone or RAL colour in gloss or matt finish

### RET006

1000 (W) x 330 (D) x 630 (H)

### RET007

1000 (W) x 330 (D) x 730 (H)

### PLANT SPECIFICATIONS

Silk plants planted in a standard 290 (W) x 290 (D) x 250 (H) stacker liner with bark chips covering the top. 3 Plants per planter is required

\*This is the only option as the stacker liner has a lip that catches into the top frame of the Retro 6/7 planter



## RETRO 8A/9A PLANTER

20mm Square tube metal frame with polyethylene cubi box / Colour to be specified on order / Can match any Pantone or RAL colour in gloss or matt finish

### RET008A

335 (W) x 335 (D) x 750 (H)

### RET009A

335 (W) x 335 (D) x 840 (H)

### PLANT SPECIFICATIONS

Silk plant planted in 230 (W) x 230 (D) x 230 (H) Polystyrene base that is painted brown to the top and supplied with bark chips



## MALUMA PLANTER

**MAL701** - 32cm liner  
500 Ø x 770 (H)  
\*Shown in matt white

**MAL705** - 40cm liner  
700 Ø x 1300 (H)  
\*Shown in cement finish

Polyethylene planter / Fits 32cm or 40cm liner / Suitable for indoor & outdoor use / Colour to be specified on order / Can match any Pantone or RAL colour in gloss or matt finish



## CYLINDER PLANTER

**CYL400**  
360 Ø x 400 (H)  
\*All shown in cement finish

**CYL600**  
360 Ø x 600 (H)

**CYL900**  
360 Ø x 900 (H)

Polyethylene planter / Fits 32cm liner / Suitable for indoor & outdoor use / Colour to be specified on order / Can match any Pantone or RAL colour in gloss or matt finish

## SILK PLANTS

Planted in 32cm liners, supplied with bark chips



ZAMIOCULCUA  
ZAM60CM

YUCCA  
YUCRED

ZEBRA  
DIFFENBACHIA  
GDB109

MOTHER-IN-LAW  
GDB002

HAPPY JOURNEY  
GDB113

ARECA PALM  
ARECA3FT - 100cm (H)  
ARECA5FT - 150cm (H)





## CUBIS PLANTER

**CBP800**  
400 (W) x 400 (D) x 800 (H)

Polyethylene planter / Fits 32cm liner / Suitable for indoor & outdoor use / Colour to be specified on order / Can match any Pantone or RAL colour in gloss or matt finish



## ECO SQUARE PLANTER

**ECO800** - Short  
360 Ø x 800 (H)

**ECO1000** - Tall  
360 Ø x 1000 (H)

Polyethylene planter / Fits 32cm liner / Suitable for indoor & outdoor use / Colour to be specified on order / Can match any Pantone or RAL colour in gloss or matt finish



## ECO CONE PLANTER

Polyethylene planter / Fits 32cm liner / Suitable for indoor & outdoor use / Colour to be specified on order / Can match any Pantone or RAL colour in gloss or matt finish

**ECOC800** - Short  
360 Ø x 800 (H)

**ECOC950** - Tall  
360 Ø x 950 (H)

**ECOC1060** - With extended Aluminium top  
360 Ø x 1060 (H)

SINCE

1946

# BRANCH FOOTPRINT

## **GAUTENG**

[gauteng@cecilnurse.co.za](mailto:gauteng@cecilnurse.co.za)

T (011) 345-1500

1 Makro Place, Sunnyrock, Germiston, 1401

## **CAPE TOWN**

[capetown@cecilnurse.co.za](mailto:capetown@cecilnurse.co.za)

T (021) 461-1270

The Boulevard Office Park, Podium Level, Block A,  
Searle Street, (off Nelson Mandela Boulevard),  
Woodstock, Cape Town, 7925

## **DURBAN**

[durban@cecilnurse.co.za](mailto:durban@cecilnurse.co.za)

T (031) 569-6081

Thynk Retail Park, Unit 8,  
Riverhorse Road, Riverhorse Valley, Durban, 4018

## **PIETERMATRIZBURG**

[pietermaritzburg@cecilnurse.co.za](mailto:pietermaritzburg@cecilnurse.co.za)

T (033) 342-8307

52 Chief Albert Luthuli Street, (Old Commercial  
Road), Pietermaritzburg, 3201

## **EAST LONDON**

[eastlondon@cecilnurse.co.za](mailto:eastlondon@cecilnurse.co.za)

T (043) 743-1531

Shop 3B, Bonza Bay Road, Beacon Bay  
Crossing Centre, Beacon Bay, East London, 5241

## **GQEBERHA**

[portelizabeth@cecilnurse.co.za](mailto:portelizabeth@cecilnurse.co.za)

T (041) 405-1000

14 Fern Road, Fairview, Port Elizabeth, 6070

## **BLOEMFONTEIN**

[bloemfontein@cecilnurse.co.za](mailto:bloemfontein@cecilnurse.co.za)

T (051) 430-3921

111 President Reitz Ave, Westdene,  
Bloemfontein, 9301

## **KIMBERLEY**

[kimberley@cecilnurse.co.za](mailto:kimberley@cecilnurse.co.za)

T (053) 831-1112

49 Long Street, Kimberley, 8301

## **MBOMBELA (NELSPRUIT)**

[nelspruit@cecilnurse.co.za](mailto:nelspruit@cecilnurse.co.za)

T (013) 492-1462

17A Vintage Drive, Mbombela, 1200

## **NAMIBIA**

[windhoek@cecilnurse.com](mailto:windhoek@cecilnurse.com)

T (00264) 61 385-700

16 Gold Street, Prosperita industrial park,  
Windhoek, Namibia

## **BOTSWANA**

[sales@cnonline.co.bw](mailto:sales@cnonline.co.bw)

T (00267) 395-6578

Plot 75749, The Design Quarter, Unit 11,  
Setlhoa Village, Gaborone, Botswana

[www.cecilnurse.co.za](http://www.cecilnurse.co.za)

[info@cecilnurse.co.za](mailto:info@cecilnurse.co.za)

086 office (633423)



